

# NINZ

FIREDOORS

## General brochure

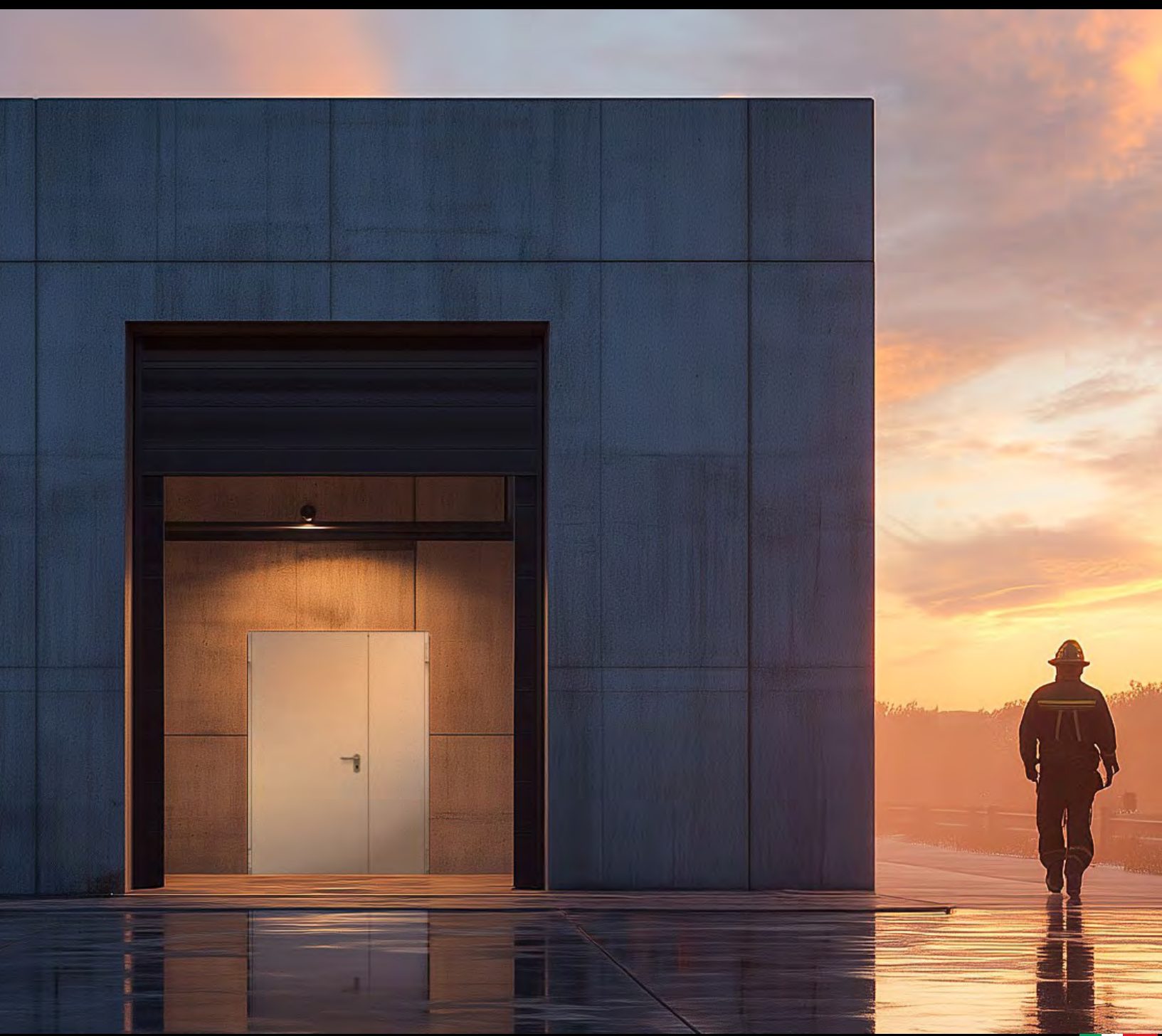



## **Main index NINZ**

|   |               |
|---|---------------|
| COMPANY PRESENTATION                        | 2 - 5         |
| <b>FIRE DOORS Univer and Proget</b>         | <b>6 - 55</b> |
| MULTIPURPOSE DOORS Rever, Univer and Proget | 56 - 118      |
| PAINTING AND NDD DECORATIONS                | 119 - 123     |
| DOOR ACCESSORIES                            | 124 - 147     |
| EMERGENCY HANDLES AND PANIC BARS            | 148 - 183     |
| INFORMATION, NOTICES                        | 184 - 185     |

### PRESENTATION - THE RELIABILITY OF EXPERIENCE

Ninz S.p.A. is Italy's leading producer of fire doors with a 70% market share. Consolidated experience in the sector, familiarity with standards and optimal quality-price ratios are the company's most distinguishing features. Over the years it has broadened its offer to include multipurpose metal doors and a wide range of accessories. In addition to Italy, Ninz S.p.A. also markets its products in more than 60 countries each year.

Production takes place in two different facilities - Bolzano and Ala (TN), where the departments for research and development, sales and logistics are also located. In Ala a third facility is currently under construction designed to further enhance production capacity.

From its beginnings as a small family-owned metal works company in 1953, over the years the company has evolved to become a major industrial player with 250 employees. The main impetus for growth came from its owner, Karl Ninz, who first introduced the production of fire doors in 1976.

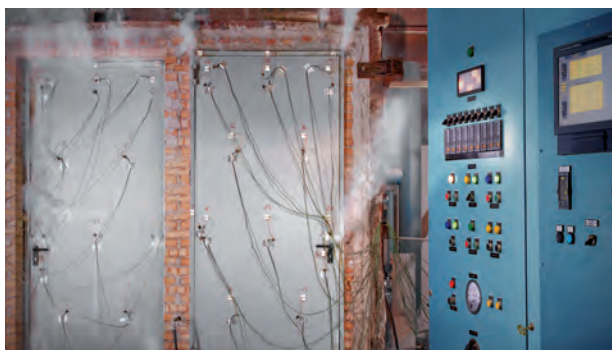

### DESIGN AND RESEARCH - EYES ON THE FUTURE

Continuous product improvements are managed by a team of expert engineers and technicians, who combine scrupulous attention to fire regulations with the practical concerns of builders, installers and locksmiths. This research, for instance, has generated certified installation methods for mounting fire doors on different types of support structures, such as masonry, plasterboard and sub-frames.



Thanks to the in-depth study of foreign standards, Ninz S.p.A. has also succeeded in certifying its products in a number of foreign countries, including France, Slovenia, Russia, Romania...



The company NINZ S.p.A. offers already today fire rated doors with "additional performances" which satisfy requirements of acoustic and thermal performances, resistance to windload and water-tightness, as well as multifunctional external doors which are CE marked.

## PRODUCTION - VERSATILITY AND DESIGN

The daily production capacity is 2000 doors, which are currently divided into the PROGET line (fire rated and multipurpose), the UNIVER line (fire rated and multipurpose) and REVER line (multipurpose). Products are made to order for even the smallest quantities, satisfying the most demanding customers thanks to the wide variety of colors, accessories and windows available.

Customization of the product reaches a pinnacle with the NDD technology (Ninz Digital Decor), a trademark, NINZ decorative painting which permits any theme (words, pictures, logos) to be reproduced on the door-leaf surface. As an expression of the NDD claim, fire doors are transformed into versatile design elements at the disposal of architects and designers. This project earned the company the prestigious "Design Security & Safety Award" in 2007.



## MARKETING - A SERVICE-ORIENTED PERSPECTIVE

Thanks to their reliability and quality, Ninz fire doors are used throughout Italy and in many countries across the world in public buildings where safety is at a premium: schools, hospitals, convention centers, shopping malls, manufacturing sites, hotels, museums...

The distribution within Italy is capillary thanks to a dense network of retailers supported by over one hundred sales agents.

Punctual delivery - one of the company's strongest points - is guaranteed by the careful planning of the production and by the quality transport services, which are both organized in-house.

The service that Ninz S.p.A. offers its customers is completed by the internal technical-sales department, which assists agents and customers in the pre- and post-sales phases, and by the fitting department, which directly follows product installations at the customer's request.

For international distribution, Ninz S.p.A. draws on (depending on the country) agents, exclusive retailers and networks of retailers supported by a dedicated internal technical-sales department.

Daily shipment to France is possible thanks to the special wooden-crates packaging and the local logistics network that has been created. Due to its great success, this service will soon be extended to other European countries.

### ISO 9001 : 2015 CERTIFICATION

Ninz Company has always been aware of the importance of quality in the global market as a strategic factor for the success of businesses. Over the years, it has been constantly striving in order to keep these aims as a priority. According to these values, it arose from the need of concretely demonstrating achieved goals, such as quality and mutual satisfaction among customers and suppliers. As a result, the company made up the decision of undertaking the development of a quality management system, certified according to the EN ISO 9001:2015 standard under the control and verification of the certifying body CERTIFICARSI EOOD.

In summary, the EN ISO 9001:2015 system enables the overall satisfaction of all stakeholders (customers, suppliers, companies, and employees) through:

- Definition of roles and responsibilities
- Definition of operational procedures
- Fulfilment of contracts and laws
- Staff motivation and optimization of time and resource utilization, in order to increase productivity
- Cost reduction, revenue increase and overall efficiency improvement
- Achievement of company purposes
- Continuous improvement of performance and corporate image.



CERTIFICATO ◆ CERTIFICADO ◆ CERTIFIKAT ◆ 認證證書 ◆ CERTIFICATE ◆ ZERTIFIKAT



## CERTIFICATO

Nr. 50 100 17297 Rev.001

SI ATTESTA CHE / THIS IS TO CERTIFY THAT  
 IL SISTEMA DI GESTIONE PER LA QUALITÀ DI  
 THE QUALITY MANAGEMENT SYSTEM OF



**NINZ S.p.A.**

SEDE LEGALE E OPERATIVA /  
 REGISTERED OFFICE AND OPERATIONAL SITE:

**CORSO TRENTO 2/A  
 IT - 38061 ALA (TN)**

SEDE OPERATIVA: VEDI ALLEGATO 1 / OPERATIONAL SITES: SEE ANNEX 1

È CONFORME AI REQUISITI DELLA NORMA  
 HAS BEEN FOUND TO COMPLY WITH THE REQUIREMENTS OF

**UNI EN ISO 9001:2015**

QUESTO CERTIFICATO È VALIDO PER IL SEGUENTE CAMPO DI APPLICAZIONE  
 THIS CERTIFICATE IS VALID FOR THE FOLLOWING SCOPE OF APPLICATION

**Progettazione, produzione e posa in opera di chiusure tagliafuoco,  
 porte metalliche e maniglioni antipánico e commercializzazione di  
 accessori di completamento (IAF 17, 28)**

**Design, production and installation of fire door closings, metal doors  
 and panic bar and trade of complementary accessories (IAF 17, 28)**

|   |  |
|---|--|
| Per l'Organismo di Certificazione<br>For the Certification Body<br><b>TUV Italia S.r.l.</b>   | Validità / Validity<br>Dal / From: <b>2024-01-27</b><br>Al / To: <b>2027-01-26</b>   |
| <b>ACCREDIA</b><br>SGQ N° 049A<br><small>Ministero degli Affari Regionali e del Mezzogiorno<br/>D.L. 98/04/02<br/>Regolamento UE 1701/2003 e L. 488/99<br/>Integrazione Regolamento</small> | <i>Francesco Scarlata</i><br><b>Francesco Scarlata</b><br><small>Direttore Divisione Business Assurance<br/>Business Assurance Division Manager</small><br>Data emissione /<br>Issuing Date<br><b>2024-01-17</b> |

**PRIMA CERTIFICAZIONE / FIRST CERTIFICATION: 2012-01-27 (EMESSO DA ALTRO OCCI / ISSUED BY OTHER CIB)**  
 "LA VALIDITÀ DEL PRESENTE CERTIFICATO È SOSPESA PER 3 (TRE) MESI E AL TERMINE COMPLETO DEL SISTEMA DI  
 GESTIONE AZIENDALE CON PERIODICITÀ TRIENNALE"  
 "THE VALIDITY OF THE PRESENT CERTIFICATE DEPENDS ON THE ANNUAL SUPERVISANCE EVERY 12 MONTHS AND ON THE COMPLETE REVIEW OF  
 COMPANY'S MANAGEMENT SYSTEM AFTER THREE YEARS"

### CRIBIS PRIME COMPANY CERTIFICATE

Ninz S.p.A. has been awarded the Cribis Prime Company certificate by Cribis Dun & Bradstreet, an organisation that operates globally in the field of business information and collects reports on over 200 million companies in over 230 countries.

This new recognition for the 2018 year of reliability confirms our ability to maintain our leadership position, already recognised since 2015 with the 'Rating Cribis D&B 1' certificate. We have been recognised for the quality and product level, as well as for the effective organisational, administrative and financial management of the company.

The "Prime Company" certificate attests the solidity of our company, the punctuality in payments and our reliability, which is based exclusively on its own strong financial position and the total absence of debt to credit institutions.

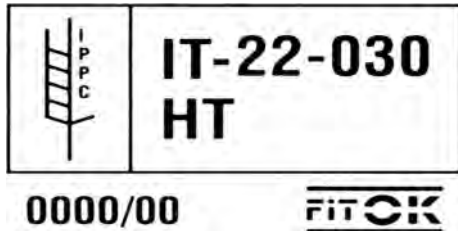

### FITOK VOLUNTARY PHYTOSANITARY LABEL

One of Ninz S.p.A.'s key strengths has always been the punctual delivery of its products, which is made possible by the company's in-house packaging expertise. This packaging offers maximum protection against impacts during transport and perfect storage at the customer's premises before installation.

Considering this, Ninz S.p.A. has taken steps to preserve the possibility of sending its packaging to countries where phytosanitary treatment of wood is mandatory. It is important to note that wood, when used as a packaging material, represents a potential channel for the introduction and spread of harmful organisms. This is why it was necessary to implement certain phytosanitary measures in order to avoid any potential economic and environmental impacts on the world's forest heritage.

The Conlegno consortium has been recognised by the Ministry of Agriculture, Food and Forestry as the managing entity of the international product mark IPPC/FAO, which certifies phytosanitary procedures and treatments in compliance with ISPM Regulation N°15.

Ninz S.p.A. has been a member of the Conlegno consortium since 2008, obtaining the authorisation to manage and maintain the FI-TOK voluntary phytosanitary mark. Currently, Ninz purchases exclusively heat-treated wood semi-finished products from suppliers, free from parasites, which it uses to produce made-to-measure pallets and cages. Ninz S.p.A. has its own specially constructed automated plant for this purpose. As a result, Ninz is able to meet its customers' requests to mark pallets and cages with the FITOK phytosanitary mark for shipment to non-European countries that require compliance with ISPM Regulation N°15.



**"state of the art in fire protection technology"**





## **UNIVER NINZ Doors**

*FIRE RATED VERSION*

|  |                |
|--|----------------|
| <b>FEATURES</b>                                  | <b>8 - 11</b>  |
| <b>SPECIFIC OPTIONAL ACCESSORIES</b>             | <b>12 - 13</b> |
| <b>ADDITIONAL PERFORMANCES</b>                   | <b>14 - 22</b> |
| <b>DOOR CROSS SECTIONS - MEASUREMENTS</b>        | <b>23</b>      |
| <b>INSTALLATION METHODS</b>                      | <b>24</b>      |
| <b>ORDER MEASUREMENTS</b>                        | <b>25- 26</b>  |
| <b>OPENING MEASUREMENTS - OVERALL DIMENSIONS</b> | <b>27</b>      |

## WHAT MAKES THEM SPECIAL?

### “Quality first”

- Fully galvanized door, including the “hidden” parts
- Made of “Sendzimir” processed hot-galvanized sheet metal
- Corrosion protection also provided along cut edges of the metal sheets
- Painted with epoxy-polyester thermoset powders in a 180 degrees (Celsius) oven
- Substantial paint layer (70 microns plus)
- Optimal corrosion resistance demonstrated by 500 hour salt-fog test
- Unaffected by severe climate changes, demonstrated by 2000 hours with +60° to -10° cycles at 75% humidity
- Finishing with high-quality aesthetics
- Orange skin anti-scratch structured paint
- Customizable with wide selection of RAL colors

### “Practicality of use”

- Door reversibility
- Indication of door opening direction not necessary
- Reduction of stock for retailers
- Simplifies choices for end-customers
- Multiple installation methods for each door
- Type approvals for anchors for mortar fixing or expansion screws

### “Conformity to standards”

- In-house Ninz R&D with specialized testing equipment
- Fire testing in accordance with UNI 9723 and EN 1634-1
- Mechanical testing for the CE marking of accessories
- CE-marked door accessories studied and sized to meet standard European requirements
- Careful selection of materials and manufacturing methods
- Strict product testing for conformity to declared technical standards
- Absolute functional certainty over time
- Doors “type approved” in compliance with M.D. 21 June 2004
- Products delivered with the documentation required by current regulations

### “Manufacturing technology”

- Manufacturing in modern and functional facilities which employ the latest technologies to maintain high quality levels and product uniformity
- The entire production process - from raw materials to painted and packaged products - takes place inside Ninz’s own facilities, ensuring a 360 degree door control

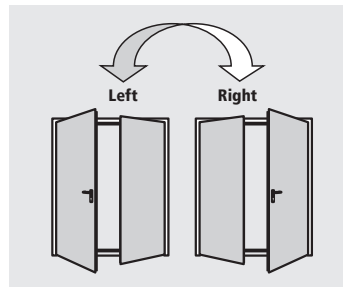
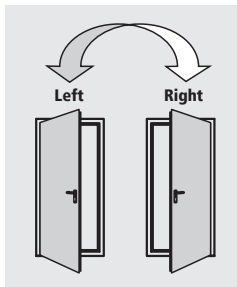

One-leaved doors available in the following classes:

E 60 EI<sub>2</sub> 60 EI<sub>2</sub> 90 REI 120 EI<sub>2</sub> 60 CE EI<sub>2</sub> 90 CE



Two-leaved doors available in the following classes:

EI<sub>2</sub> 60 EI<sub>2</sub> 90 REI 120 EI<sub>2</sub> 60 CE EI<sub>2</sub> 90 CE



**STANDARD ELEMENTS**

**Door leaf**

- Made of "Sendzimir" processed hot-galvanized sheet metal, press folded and electro welded
- Perimetral rebate on 4 sides
- Internally reinforced with hot-galvanized steel profiles
- Heat-insulated with treated mineral wool
- Internal stiffeners for overhead door closer and panic bar

**Doorframe**

- Made of "Sendzimir" processed hot-galvanized sheet metal
- Grooves for thermo expansive sealing and rebate sealing
- Suitable for anchors for mortar fixing or expansion screws
- Detachable rebate for application on finished flooring
- Removable threshold for thresholdless installation
- Strike plates in black plastic for lock bolt and safety bolts
- Assembled doorframes for one-leaved doors
- Assembly required for two-leaved doorframes

**Thermo expansive sealing**

- Mounted on vertical doorframe profiles and central vertical profiles on two-leaved doors
- For on-site mounting on the doorframe's upper cross-beam
- Mounted above and below the EI<sub>2</sub>90 and REI 120 leaves

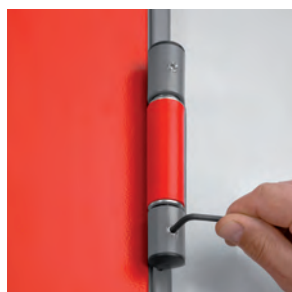

**Hinges**

- Nr. 2 three-wing hinges for each leaf
- of which one ball-bearing hinge with screws for vertical adjustment of the leaf, **CE** marked as per EN 1935, classified for up to 160 kg load, 200.000 cycles durability, suitable for fire door use
- and one hinge with self-closing spring

**Safety bolts**

- Nr. 2 safety bolts on hinge side leaf edge



**Locking mechanism**

- Reversible locking mechanism with bolt and central lock
- **CE** marked in conformity with EN 12209 standard
- Insert with patent key, Euro profile cylinder ready

**Handle**

- Fire rated handle in black plastic with steel core
- Steel installation plate with cylinder hole
- Cover plate in black plastic
- Fastener screws and patent key insert

**INCLUDED ACCESSORIES**

**Closing regulator**

- Two-leaved doors include an RC/STD closing regulator to ensure the correct closing sequence of the leaves
- CE marking in conformity with EN 1158 standard

**Locking mechanism for inactive leaf**

- "Flush-bolt" automatic locking of the inactive leaf
- Lever control for unlocking

**Upper coupling system for the inactive leaf**

- Inactive leaf lock activated device which inserts rod into the upper strike box
- Upper strike box in black plastic with steel roller

**Lower coupling system for the inactive leaf**

- Vertical rod with steel point which inserts into lower strike box
- Floor catch (floor-mounted floor catch) made of self-extinguishing black plastic, for doors without threshold
- Floor catch in black plastic with a steel roller, for doors with threshold

**Identification plate**

- Metal tag with door identification data, in accordance with current regulations



Standard paint - group 01: RAL 9010

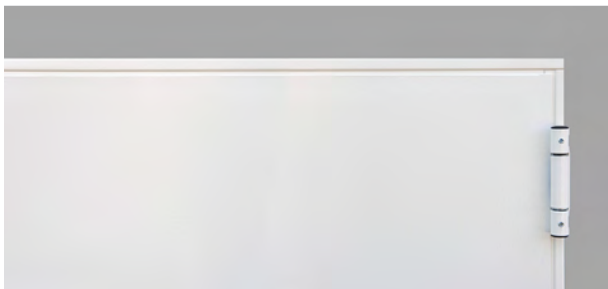

**Finishing**

- Standard painted with epoxy-polyester thermoset powders in a 180 degrees oven, orange skin, anti-scratch finishing
- Standard paint RAL 9010

**Standard packaging**

- Single door wrapped into stretchable polyethylene (PE) film
- Assembled doorframes for one-leaved doors
- Assembly required for doorframes for two-leaved doors
- Palletized on wooden pallets

**NOTE**

If the door ever needs to be repainted, follow the precise instructions on the "Painting" section.

**OPTIONAL ACCESSORIES**

A wide variety of accessories and surface finishes are available on request for maximum value enhancement of Univer doors to your own specific needs.

The proper accessories can help resolve:

**Safety-related needs**

- Doors for panic exits (see panic bars)
- Doors for emergency exits (see emergency exit handles)
- Open doors which must be closed in case of fire (see leaf holding systems)

**Installation and utilization needs**

- Frame extensions
- Drip steel-profile
- Special fastener screws
- Kick and protection plates in stainless steel
- Windows
- Roofing

**Access-related control issues**

- Electrically-activated lock mechanisms
- Electric handle mechanisms
- Magnetic blocking mechanisms

**Performance enhancing**

- Sealing
- Cylinders
- Door closers
- Special closing regulators
- Special handles



**Customized finishing**

- Select finishing from a wide variety of RAL colours
- NDD – Ninz Digital Decor, graphic images applied with special ink jets and protected by a transparent topcoat. Infinite varieties of customizable decorations in harmony with specific door settings
- Stainless steel handles
- Colored handles

**Packaging for maximum protection**

Sturdy wooden crates protect all doors and related accessories:

- For NDD decorated doors
- On construction sites
- During shipping abroad
- For special transport



The following optional accessories make Univer doors irreversible, requiring the indication of the door opening direction when the order is placed:

- SLASH panic bar
- Panic bar for inactive leaves
- Windows
- MAC lock
- ELM/cisa and ELM/mt electric handle
- Special locks (Stel 15)
- NDD - Ninz Digital Decor

**NOTE**

Details on the optional accessories may be found in the following chapters of this brochure:

- Painting
- Accessories for metal doors
- Emergency handles and panic bars

Right-opening doors are the default selection if opening direction is not specified.

## WINDOW WITH FIRE RATED GLASS

Upon request all one- and two-leaved fire doors, excluding those E 60, EI<sub>2</sub>30 and EI<sub>2</sub>90 rated, may be equipped with round or rectangular windows with fire rated stratified glass and respective window frames fixed with screws. The window frame carters are included for round window and available as an optional accessory for the rectangular one.

### Limits prescribed by standard

According to standards UNI 9723 and EN 1634-1, windows may be smaller but not larger than the test sample size, and the reverse holds true for the border strip around the window which may be wider but not thinner. The following limits correspond with these restrictions.

### Borders, window position

"Border measurement" refers to the distance from the edge of the window to the wall opening of the door.

### Elevation for round windows

| window size | FM H              | position     |
|-------------|-------------------|--------------|
| Ø 300       | minimum 2050      | Y=1600       |
| Ø 300       | less than 2050    | Y=FM H - 450 |
| Ø 400       | minimum 2150      | Y=1600       |
| Ø 400       | from 2050 to 2149 | Y=1550       |
| Ø 400       | less than 2050    | Y=FM H - 500 |

### Elevation for rectangular windows

| window dimensions L x H | FM H              | position     |
|-------------------------|-------------------|--------------|
| 250/300 x 400           | minimum 2150      | Z=1450       |
| 250/300 x 400           | from 2050 to 2149 | Z=1350       |
| 250/300 x 400           | less than 2050    | Z=FM H - 700 |

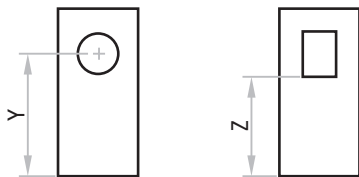

### NOTE

The positions indicated above are those standard. Different positions may be considered as long as they respect the minimum "a" and "b" border strips. The window itself may not be supplied separately except for replacements. It is always advisable for doors with windows to be equipped with door closers for controlled closing.



### NOTE

For the rectangular windows the frame carters are an optional accessory

### Round window cross section

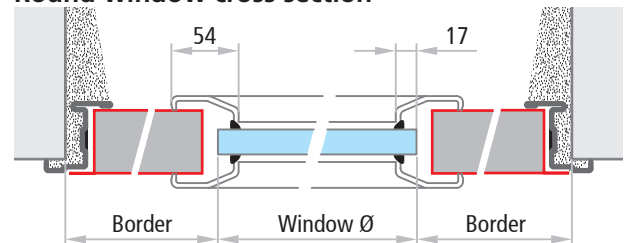

### Rectangular window cross section

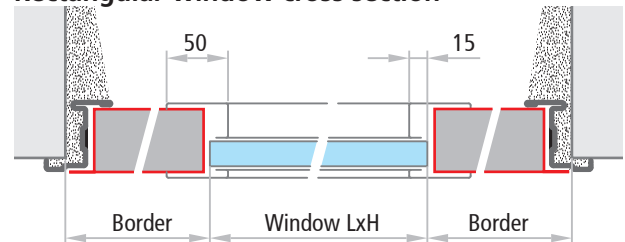

### ATTENTION

In case of external installation use windows designed for this purpose. For special instructions and recommendations for glazed fire-rated products, see the "Notices" section on the last page of the present brochure.

# Specific optional accessories

UNIVER Fire doors



UNIVER  
fire door

| Window dimensions | min. border EI <sub>2</sub> |     | min. border RE, REI |     | dimensions FM L min. |
|-------------------|-----------------------------|-----|---------------------|-----|----------------------|
|                   | a                           | b   | a                   | b   |                      |
|                   | Ø 300                       | 220 | 220                 | 300 | 740                  |
|                   | Ø 400                       | 300 | 300                 | 300 | 840                  |
|                   | Ø 300                       | 220 | 220                 | 300 | L1 740 + L2 min.     |
|                   | Ø 400                       | 300 | 300                 | 300 | L1 840 + L2 min.     |
|                   | Ø 300                       | 220 | 220                 | 300 | L1 740 + L2 740      |
|                   | Ø 400                       | 300 | 300                 | 300 | L1 840 + L2 840      |

| Window dimensions | min. border EI <sub>2</sub> |     | min. border RE, REI |     | dimensions FM L min. |             |
|-------------------|-----------------------------|-----|---------------------|-----|----------------------|-------------|
|                   | a                           | b   | a                   | b   |                      |             |
|                   | 250 x 400                   | 250 | 300                 | 300 | EI <sub>2</sub> =750 | RE, REI=850 |
|                   | 300 x 400                   | 300 | 300                 | 300 | EI <sub>2</sub> =800 | RE, REI=900 |
|                   | 250 x 400                   | 300 | 300                 | 300 | L1 850 + L2 min.     |             |
|                   | 300 x 400                   | 300 | 300                 | 300 | L1 900 + L2 min.     |             |
|                   | 250 x 400                   | 300 | 300                 | 300 | L1 850 + L2 850      |             |
|                   | 300 x 400                   | 300 | 300                 | 300 | L1 900 + L2 900      |             |

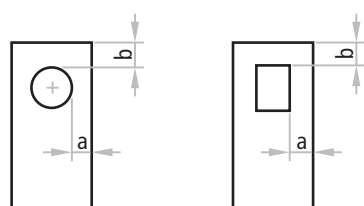

## NOTE

Round and rectangular windows not possible for one-leaved REI doors with FM L (wall opening) above 1167mm and FM H above 2150mm.

Round windows are not allowed for CE fire doors

## FRAME EXTENSIONS FOR UNIVER DOORS

### IM 12

Frame extensions to be mounted in addition to the Univer frame acting as a wall cladding. Made of "Sendzimir" processed hot-galvanized sheet metal and painted the same color as the doorframe with epoxy-polyester powders. Profile on three sides, upper corners with 45 degree joint, fixing with screws and plugs (screws and plugs not included).

IM 12: for installation on 80mm (min.) wall thickness

### IM 14

Telescopic frame extensions to be screwed to the Univer doorframe acting as a wall cladding. Consists of two overlapping profiles with a 25mm adjustable range. Made of "Sendzimir" processed hot-galvanized sheet metal painted the same color as the doorframe with epoxy-polyester powders. Profile on three sides, upper corners with 90 degree joint. Complete with fastener screws. To mount the frame extension, fixing holes need to be drilled into doorframe on site. Combine with sealing to conceal the screw heads.

IM 14: for installation on 135mm (min.) wall thickness

## REBATE SEALING CR

CR sealing (for EI<sub>2</sub> doors) and sealing (for REI doors) in black extruded profile to cut and to be pressed into the dedicated groove in the perimetral frame. Sealing in black extruded profile self-adhesive to cut for application to the central joint of two-leaved doors.

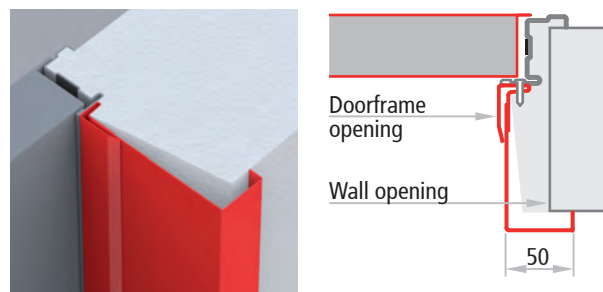
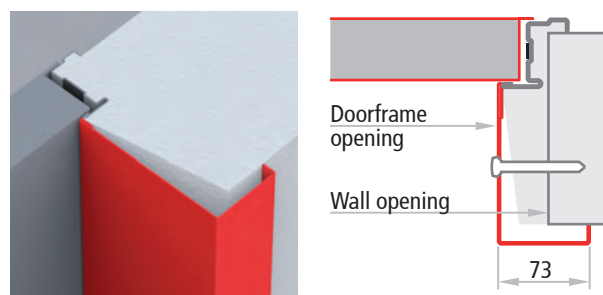

# Additional performances

UNIVER Fire doors

**NINZ**<sup>®</sup>  
FIRE DOORS

UNIVER  
fire door



## INTERNAL PEDESTRIAN DOORS

Test report No. CPR/35/05/2019 (E 60)

Test report No. CPR/35/04/2019 (EI<sub>2</sub>60)

Test report No. CPR/35/07/2019 (REI 120/EI<sub>2</sub>90)

Pedestrian interior doors are not yet subject to marking as the relevant standard EN 14351-2 has not yet entered into force. The performances contained in the standard can however be a reference for classifying the door for indoor, such as:

- air permeability according to EN 1026:2001
- thermal transmittance according to EN ISO 10077-1:2018 e EN ISO 10077-2:2018

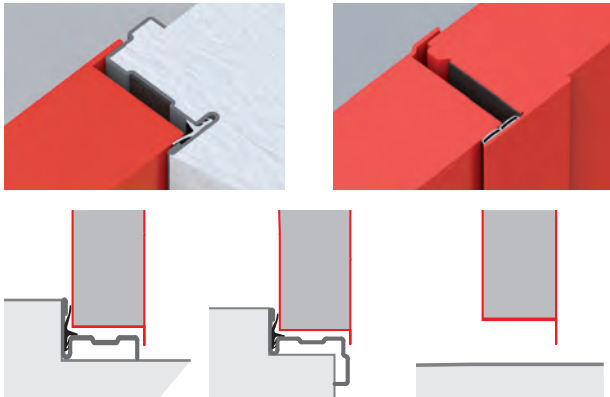

All performance values indicated in the table are valid only in presence of the following accessories or enhancements:

- Combo Thermo/CB (with lower threshold):
  - frame on all 4 sides
  - if the door is installed on an escape route, it is necessary to fill the difference in height on the push side between the floor and the lower threshold with cement mortar
  - isolation of the door frame with the filling of cement mortar
  - installation of rubber seals along the entire perimeter of the door frame including the central rebate for double leaved doors
  - sealing of the perimeter of the frame (push side) with neutral silicone
- Combo Thermo/SB (without lower threshold):
  - isolation of the door frame with the filling of cement mortar
  - installation of rubber seals along the 3 sides of the frame including the central rebate for two-leaved doors
  - sealing of the perimeter of the frame (push side) with neutral silicone

### ATTENTION

For the dimensional limits, minimum border measurements or production possibilities please refer to the specific pages of this brochure.

The values for the thermal transmittance  $W/m^2K$  shown in the table on the next page are given by the calculation according to the norm EN ISO 10077-1 done on samples of the dimensions 1,23x2,18 for areas  $\leq 3,6m^2$  and on samples of the dimensions 2,00x2,18 for areas  $> 3,6m^2$ .

Consiglio Nazionale delle Ricerche  
Istituto per la BioEconomia

CNR IBE - Via F. Biagi n. 75, San Michele all'Adige - Trento T. 0461 660111 Fax 0461 650045

|  |   |
|--|---|
| CNR - IBE<br>U 0000804 13/02/2020<br>                                    | <b>LABORATORIO SERRAMENTI<br/>E FACCIATE CONTINUE</b> |
| RAPPORTO DI PROVA N° CPR/35/06/2019<br>San Michele all'Adige, 07/02/2020 |   |

|   |
|---|
| COMMITTENTE: NINZ S.p.a.<br>Corso Trento, 2/A - 38061 Ala (TN)<br>COSTRUTTORE: NINZ S.p.a.<br>Corso Trento, 2/A - 38061 Ala (TN)<br>OGGETTO: PORTA<br>MODELLO: UNIVER REI 120 / EI <sub>2</sub> 90<br>MATERIALE: profilato metallico, coibente<br>DIMENSIONI: Spessore anta (mm) 60 |
|---|

|  |
|--|
| PROVE ESEGUITE SOTTO NOTIFICA (NB 2127):<br><input type="checkbox"/> CALCOLO DELLA TRASMITTANZA TERMICA SECONDO NORME UNI EN ISO 10077-2:2018 e UNI EN ISO 10077-1:2018<br>Note: |
|--|

|  |
|--|
| DATA ACCETTAZIONE PREVENTIVO: 23/12/2019 (prot.n. 0003210/2019)<br>DATA INIZIO PROVE: 04/02/2020 DATA FINE PROVE: 06/02/2020 |
|--|

|   |   |
|---|---|
| IL PRESENTE RAPPORTO DI PROVA È COMPOSTO DA:<br>n° 05 pagine di rapporto di prova<br>n° 23 pagine di allegati tecnici | DIRETTORE TECNICO<br>G. Pasetto<br><br> |
|---|---|

MOD 00 00 13 - Format Rev.05 Rapporto di prova rilasciato sotto notifica ai sensi del Reg. (UE) n. 305/2011 (CPR) Pg. 1/5

FIRENZE BOLOGNA CATANIA ROMA SASSARI S.MICHELE ALL'ADIGE



C.F. 8006430696 - P.IVA 02118311006

PEC: protocollo.ibe@pec.cnr.it

# Additional performances

UNIVER Fire doors



| Univer Fire doors<br>Test report CPR/35/07/2019<br>Test report CPR/35/05/2019<br>Test report CPR/35/04/2019<br> |                       | DIMENSION<br>FM L X H | Combo Thermo/CB<br>with lower threshold<br>and gasket on all 4 sides |                        |                        | Combo Thermo/SB<br>without lower threshold CR<br>and gasket on 3 sides |                        |                        |
|--|-----------------------|-----------------------|--|------------------------|------------------------|--|------------------------|------------------------|
|  |                       |                       | EI <sub>2</sub> 60   | E60                    | REI 120                | EI <sub>2</sub> 60   | E60                    | REI 120                |
| Without window<br>  | UNI EN 1026:2001      | ≤ 3,6 m <sup>2</sup>  |  |                        |                        |  |                        |                        |
|  | Air permeability      |                       | Class 2  | Class 2                | Class 2                | N.PD.  | N.PD.                  | N.PD.                  |
|  | UNI EN 10077-1-2:2018 |                       |  |                        |                        |  |                        |                        |
|  | Thermal transmittance |                       | 1,5 W/m <sup>2</sup> K   | 1,6 W/m <sup>2</sup> K | 1,5 W/m <sup>2</sup> K | 1,5 W/m <sup>2</sup> K   | 1,6 W/m <sup>2</sup> K | 1,5 W/m <sup>2</sup> K |

UNIVER fire door

# Additional performances

UNIVER Fire doors

**NINZ**<sup>®</sup>  
FIRE DOORS

UNIVER  
fire door

## INTERNAL PEDESTRIAN DOORS



### SMOKE CONTROL

Test report IFT N° 16-000122-PR03

This is the ability of a door set to reduce or eliminate the passage of smoke from one side of the door to the other. Two levels of smoke performance are defined.

Smoke control Sa: when the maximum dispersion value measured at room temperature and at a pressure of 25 Pascal is not greater than 3 m<sup>3</sup>/h per metre through the gap between the door leaf and the door frame excluding eventual losses through the floor threshold.

Smoke control S200: when the maximum dispersion value, measured at room temperature and 200 C and up to a pressure of 50 Pascal, is not greater than 20 m<sup>3</sup>/h for a single door or 30 m<sup>3</sup>/h for a two-door door.

The smoke tightness is verified with a specific technical test in accordance with UNI EN 1634-3, while the classification is provided by UNI EN 13501-2 according to the following criteria:

Sa considers only the seal at room temperature

S200 considers the seal at room temperature and at 200 C

UNIVER doors are certified for smoke control according to EN 1634-3 and classified Sa/S200 according to EN 13501-2 . The price list lists the Combos which add these additional performances to the door.

### ATTENTION

The smoke control performance is only valid in presence of the following accessories or enhancements:

- no fixed threshold
- filling of the slot between frame and wall with cement mortar
- installation of rubber seals along the entire perimeter of the door frame including the central rebate for double leaved doors
- presence of the automatic door sweep
- closing regulator RC/STD for the correct closure of double leaved doors



## S200, C5 ENHANCED PERFORMANCES

### Mandatory accessories

| Enhanced performance | features                   | type     | mandatory optional accessories                   | reference in brochure           |
|----------------------|----------------------------|----------|--|---------------------------------|
| S200                 | Smoke control Door         | 1 leaf   | - rubber seal CR<br>- Nr. 1 automatic door sweep | UNIVER fire door<br>ACCESSORIES |
|                      |                            | 2 leaves | - rubber seal CR<br>- Nr. 2 automatic door sweep | UNIVER fire door<br>ACCESSORIES |
| C5                   | Durability: 200,000 cycles | 1 leaf   | - Nr. 1 door closer                              | ACCESSORIES                     |
|                      |                            | 2 leaves | - Nr. 2 door closers                             | ACCESSORIES                     |

## MECHANICAL STRENGTH PERFORMANCES

Test report according to norm EN 947, EN 948, EN 949, EN 950

### Performance requirements and classifications

| class              | tested FM L X H dimensions | type     | description of the performance           | reached class | standard reference |
|--------------------|----------------------------|----------|--|---------------|--------------------|
| EI <sub>2</sub> 60 | 2000 (1000 + 1000) x 2125  | 2 leaves | resistance to vertical load              | 4             | EN 1192:2002       |
|                    |                            |          | resistance to static torsion             | 4             | EN 1192:2002       |
|                    |                            |          | resistance to soft and heavy body impact | 4             | EN 1192:2002       |
|                    |                            |          | resistance to hard body impact           | 3             | EN 1192:2002       |

# Additional performances

UNIVER Fire doors



## EXTERNAL PEDESTRIAN DOORS

Certificate CE 1404-CPR-3734 for EI<sub>2</sub>60

Certificate CE 1404-CPR-3735 for EI<sub>2</sub>90

EN 16034:2014 and EN 14351-1:2006+A2:2016



According to standards EN 16034 and EN 14351-1, an external door is defined as a door that separates the internal climate from the external environment of a building. For this application, doors must be CE marked in accordance with EN 16034:2014 and EN 14351-1:2006+A2:2016. Furthermore, if the door is installed along an escape route and equipped with a panic or emergency exit device, it is also subject to the assessment and verification of constancy of performance under "System 1". This requires the manufacturer to hold a Certificate of Constancy of Performance issued by a Notified Body — for NINZ S.p.A., those are certificates 1404 - CPR - 3734 and 1404 - CPR - 3735.

Univer fire doors for external use must be ordered with the specific CE Combo Est options available in the Univer fire door price list, selected based on the essential requirements indicated in the tables on the following pages, and considering those that are mandatory according to the applicable national regulations. This ensures that each door is provided with the required CE marking and the documentation specified by the current legislation.

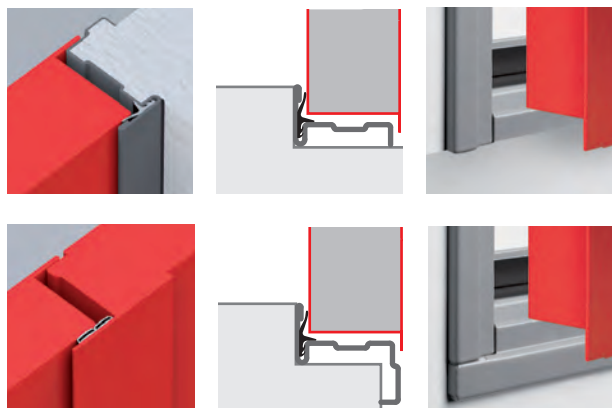

## ATTENTION

For dimensional limits, minimum edge requirements and production options, please refer to the specific pages of this catalogue. The thermal transmittance values (W/m<sup>2</sup>K) shown in the tables on the following pages are calculated in accordance with EN ISO 10077-1, applied to samples measuring 1.23 x 2.18 m for areas ≤ 3.6 m<sup>2</sup> and to samples measuring 2.00 x 2.18 m for areas > 3.6 m<sup>2</sup>. All performance values listed in the table are valid only if the door is installed with the following accessories and measures:

- presence of a bottom rebate threshold
- in case of installation along an escape route, the floor on the push side must be raised to fully level the gap between the floor and the bottom threshold
- frame insulation by filling with polyurethane foam or cement-based mortar
- application of sealing gaskets along the entire perimeter of the frame and on the central mullion in double-leaf doors
- sealing of the frame's perimeter edge (on the push side) with neutral silicone
- for doors with vision panels: installation of external fire-resistant glazing sized 300x400 mm

## NOTES

For information regarding outdoor installation, please refer to the "Warnings" section on the last page of this catalogue.



ZAVOD ZA  
GRADBENIŠTVO  
SLOVENIJE  
SLOVENIAN  
NATIONAL BUILDING  
AND CIVIL ENGINEERING  
INSTITUTE  
Dimčeva, ulica 12  
1000 Ljubljana  
Slovenija  
info@zag.si  
www.zag.si  
Notified certification body  
NR 1404

### Certificate of constancy of performance

1404 – CPR – 3734

In compliance with Regulation (EU) No 305/2011 of the European Parliament and of the Council of 9 March 2011 (the Construction Products Regulation or CPR), this certificate applies to the construction product

**Single and double leaf fire door UNIVER EI 60**  
(doors that fall within the scope of standard EN 14351-1:2006+A2:2016)

placed on the market under the name or trade mark of  
**NINZ S.p.A.,**  
**Corso Trento 2, 38061 Ala (TN), Italy**

and produced in the manufacturing plant  
**NINZ S.p.A.,**  
**Corso Trento 2, 38061 Ala (TN), Italy.**

This certificate attests that all provisions concerning the assessment and verification of constancy of performance described in Annex ZA of the standards

**EN 16034:2014 and EN 14351-1:2006+A2:2016**

under system 1 for the performance set out in this certificate are applied and that the factory production control conducted by the manufacturer is assessed to ensure the

**constancy of performance of the construction product.**

This certificate was first issued on 4. 6. 2024 and will remain valid until 4. 6. 2029 as long as neither the harmonised standards, the construction products, the AVCP method nor the manufacturing conditions in the plant are modified significantly, unless suspended or withdrawn by the notified product certification body.

Detailed information about the scope of the product is given in the annex to this certificate.

Ljubljana, 4. 6. 2024



Authorised signatory of the Certification body:  
mag. Egon Mirost, univ.dipl.inž.grad.

# Additional performances

UNIVER Fire doors

**NINZ**<sup>®</sup>  
FIREDOORS

UNIVER  
fire door





| UNIVER Fire Door EI <sub>2</sub> 60<br><br>Certificate CE:<br>1404-CPR-3734 |   | Angular Frame | Combo with bottom rebate,<br>CR compression seal on all four sides<br>and door closer for C5 version |                         | Combo with CR compression seal on 3<br>sides, drop-down seal<br>and door closer for C5 version |                                 |
|--|---|---------------|--|-------------------------|--|---------------------------------|
|  |   |               | CE   | CE C5                   | CE S200/GS<br>CE S 200/GSV   | CE S200/GS C5<br>CE S200/GSV C5 |
| Without window<br>   | <b>EN 16034:2014</b>                    |               |  |                         |  |                                 |
|  | Fire resistance                         | ✓             | EI <sub>2</sub> 60   | EI <sub>2</sub> 60      | EI <sub>2</sub> 60   | EI <sub>2</sub> 60              |
|  | Smoke control                           | ✓             | N.P.D.   | N.P.D.                  | Sa / S200  | Sa / S200                       |
|  | Ability to release / lock               | ✓             | N.P.D.   | N.P.D.                  | N.P.D.   | N.P.D.                          |
|  | Self-closing                            | ✓             | C  | C                       | C  | C                               |
|  | Durability of release mechanism         | ✓             | N.P.D.   | N.P.D.                  | N.P.D.   | N.P.D.                          |
|  | Durability of self-closing              |               |  |                         |  |                                 |
|  | - against degradation                   | ✓             | 0  | 5                       | 0  | 5                               |
|  | - against corrosion                     | ✓             | N.P.D.   | N.P.D.                  | N.P.D.   | N.P.D.                          |
|  | <b>EN 14351-1:2006+A2:2016</b>          |               |  |                         |  |                                 |
|  | Air permeability                        | ✓             | 2  | 2                       | 2  | 2                               |
|  | Water tightness                         | ✓             | 2A   | 2A                      | N.P.D.   | N.P.D.                          |
|  | Wind load resistance                    |               |  |                         |  |                                 |
|  | - Door with FM ≤ 900x2150               | ✓             | C2   | C2                      | N.P.D.   | N.P.D.                          |
|  | - Door with FM > 900x2150               | ✓             | N.P.D.   | N.P.D.                  | N.P.D.   | N.P.D.                          |
|  | Impact resistance                       | ✓             | N.P.D.   | N.P.D.                  | N.P.D.   | N.P.D.                          |
|  | Load-bearing capacity of safety devices | ✓             | Exceeds  | Exceeds                 | Exceeds  | Exceeds                         |
|  | Acoustic performance                    | ✓             | N.P.D.   | N.P.D.                  | N.P.D.   | N.P.D.                          |
|  | Thermal transmittance                   | ✓             | 1,49 W/m <sup>2</sup> K  | 1,49 W/m <sup>2</sup> K | N.P.D.   | N.P.D.                          |
|  | Ability to release / open               | ✓             | N.P.D.   | N.P.D.                  | N.P.D.   | N.P.D.                          |
| With window<br>300x400<br>  | <b>EN 16034:2014</b>                    |               |  |                         |  |                                 |
|  | Fire resistance                         | ✓             | EI <sub>2</sub> 60   | EI <sub>2</sub> 60      | EI <sub>2</sub> 60   | EI <sub>2</sub> 60              |
|  | Smoke control                           | ✓             | N.P.D.   | N.P.D.                  | Sa / S200  | Sa / S200                       |
|  | Ability to release / lock               | ✓             | N.P.D.   | N.P.D.                  | N.P.D.   | N.P.D.                          |
|  | Self-closing                            | ✓             | C  | C                       | C  | C                               |
|  | Durability of release mechanism         | ✓             | N.P.D.   | N.P.D.                  | N.P.D.   | N.P.D.                          |
|  | Durability of self-closing              |               |  |                         |  |                                 |
|  | - against degradation                   | ✓             | 0  | 5                       | 0  | 5                               |
|  | - against corrosion                     | ✓             | N.P.D.   | N.P.D.                  | N.P.D.   | N.P.D.                          |
|  | <b>EN 14351-1:2006+A2:2016</b>          |               |  |                         |  |                                 |
|  | Air permeability                        | ✓             | 2  | 2                       | 2  | 2                               |
|  | Water tightness                         | ✓             | 2A   | 2A                      | N.P.D.   | N.P.D.                          |
|  | Wind load resistance                    |               |  |                         |  |                                 |
|  | - Door with FM ≤ 900x2150               | ✓             | C2   | C2                      | N.P.D.   | N.P.D.                          |
|  | - Door with FM > 900x2150               | ✓             | N.P.D.   | N.P.D.                  | N.P.D.   | N.P.D.                          |
|  | Impact resistance                       | ✓             | N.P.D.   | N.P.D.                  | N.P.D.   | N.P.D.                          |
|  | Load-bearing capacity of safety devices | ✓             | Exceeds  | Exceeds                 | Exceeds  | Exceeds                         |
|  | Acoustic performance                    | ✓             | N.P.D.   | N.P.D.                  | N.P.D.   | N.P.D.                          |
|  | Thermal transmittance                   | ✓             | 2,01 W/m <sup>2</sup> K  | 2,01 W/m <sup>2</sup> K | N.P.D.   | N.P.D.                          |
|  | Ability to release / open               | ✓             | N.P.D.   | N.P.D.                  | N.P.D.   | N.P.D.                          |

# Additional performances

UNIVER Fire doors

**NINZ**<sup>®</sup>  
FIRE DOORS

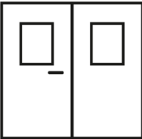
UNIVER  
fire door

| UNIVER Fire Door EI <sub>2</sub> 60<br><br>Certificate CE:<br>1404-CPR-3734   |   | Angular Frame | Combo with bottom rebate,<br>CR compression seal on all four sides<br>and door closer for C5 version |                         | Combo with CR compression seal on 3<br>sides, drop-down seal<br>and door closer for C5 version |                                 |
|--|---|---------------|--|-------------------------|--|---------------------------------|
|  |   |               | CE   | CE C5                   | CE S200/GS<br>CE S 200/GSV   | CE S200/GS C5<br>CE S200/GSV C5 |
| Without win-<br>dow<br>  | <b>EN 16034:2014</b>                              |               |  |                         |  |                                 |
|  | Fire resistance                                   | ✓             | EI <sub>2</sub> 60   | EI <sub>2</sub> 60      | EI <sub>2</sub> 60   | EI <sub>2</sub> 60              |
|  | Smoke control                                     | ✓             | N.P.D.   | N.P.D.                  | Sa / S200  | Sa / S200                       |
|  | Ability to release / lock                         | ✓             | N.P.D.   | N.P.D.                  | N.P.D.   | N.P.D.                          |
|  | Self-closing                                      | ✓             | C  | C                       | C  | C                               |
|  | Durability of release mechanism                   | ✓             | N.P.D.   | N.P.D.                  | N.P.D.   | N.P.D.                          |
|  | Durability of self-closing                        |               |  |                         |  |                                 |
|  | - against degradation                             | ✓             | 0  | 5                       | 0  | 5                               |
|  | - against corrosion                               | ✓             | N.P.D.   | N.P.D.                  | N.P.D.   | N.P.D.                          |
|  | <b>EN 14351-1:2006+A2:2016</b>                    |               |  |                         |  |                                 |
|  | Air permeability                                  | ✓             | 3  | 3                       | 3  | 3                               |
|  | Water tightness                                   | ✓             | 3A - 9B  | 3A - 9B                 | N.P.D.   | N.P.D.                          |
|  | Wind load resistance                              |               |  |                         |  |                                 |
|  | - Door with FM ≤ 2000x2150                        | ✓             | C2   | C2                      | N.P.D.   | N.P.D.                          |
|  | - Door with FM > 2000x2150                        | ✓             | N.P.D.   | N.P.D.                  | N.P.D.   | N.P.D.                          |
|  | Impact resistance                                 | ✓             | N.P.D.   | N.P.D.                  | N.P.D.   | N.P.D.                          |
|  | Load-bearing capacity of safety devices           | ✓             | Exceeds  | Exceeds                 | Exceeds  | Exceeds                         |
|  | Acoustic performance                              | ✓             | N.P.D.   | N.P.D.                  | N.P.D.   | N.P.D.                          |
|  | Thermal transmittance for FM ≤ 3,6 m <sup>2</sup> | ✓             | 1,88 W/m <sup>2</sup> K  | 1,88 W/m <sup>2</sup> K | N.P.D.   | N.P.D.                          |
|  | Thermal transmittance for FM > 3,6 m <sup>2</sup> | ✓             | 1,52 W/m <sup>2</sup> K  | 1,52 W/m <sup>2</sup> K | N.P.D.   | N.P.D.                          |
| Ability to release / open  | ✓   | N.P.D.        | N.P.D.   | N.P.D.                  | N.P.D.   |                                 |
| With window<br>300x400<br><br> | <b>EN 16034:2014</b>                              |               |  |                         |  |                                 |
|  | Fire resistance                                   | ✓             | EI <sub>2</sub> 60   | EI <sub>2</sub> 60      | EI <sub>2</sub> 60   | EI <sub>2</sub> 60              |
|  | Smoke control                                     | ✓             | N.P.D.   | N.P.D.                  | Sa / S200  | Sa / S200                       |
|  | Ability to release / lock                         | ✓             | N.P.D.   | N.P.D.                  | N.P.D.   | N.P.D.                          |
|  | Self-closing                                      | ✓             | C  | C                       | C  | C                               |
|  | Durability of release mechanism                   | ✓             | N.P.D.   | N.P.D.                  | N.P.D.   | N.P.D.                          |
|  | Durability of self-closing                        |               |  |                         |  |                                 |
|  | - against degradation                             | ✓             | 0  | 5                       | 0  | 5                               |
|  | - against corrosion                               | ✓             | N.P.D.   | N.P.D.                  | N.P.D.   | N.P.D.                          |
|  | <b>EN 14351-1:2006+A2:2016</b>                    |               |  |                         |  |                                 |
|  | Air permeability                                  | ✓             | 3  | 3                       | 3  | 3                               |
|  | Water tightness                                   | ✓             | 3A - 9B  | 3A - 9B                 | N.P.D.   | N.P.D.                          |
|  | Wind load resistance                              |               |  |                         |  |                                 |
|  | - Door with FM ≤ 2000x2150                        | ✓             | C2   | C2                      | N.P.D.   | N.P.D.                          |
|  | - Door with FM > 2000x2150                        | ✓             | N.P.D.   | N.P.D.                  | N.P.D.   | N.P.D.                          |
|  | Impact resistance                                 | ✓             | N.P.D.   | N.P.D.                  | N.P.D.   | N.P.D.                          |
|  | Load-bearing capacity of safety devices           | ✓             | Exceeds  | Exceeds                 | Exceeds  | Exceeds                         |
|  | Acoustic performance                              | ✓             | N.P.D.   | N.P.D.                  | N.P.D.   | N.P.D.                          |
|  | Thermal transmittance for FM ≤ 3,6 m <sup>2</sup> | ✓             | 2,91 W/m <sup>2</sup> K  | 2,91 W/m <sup>2</sup> K | N.P.D.   | N.P.D.                          |
|  | Thermal transmittance for FM > 3,6 m <sup>2</sup> | ✓             | 2,15 W/m <sup>2</sup> K  | 2,15 W/m <sup>2</sup> K | N.P.D.   | N.P.D.                          |
| Ability to release / open  | ✓   | N.P.D.        | N.P.D.   | N.P.D.                  | N.P.D.   |                                 |

# Additional performances

UNIVER Fire doors

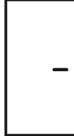

UNIVER  
fire door

| UNIVER Fire Door EI <sub>2</sub> 90<br><br>Certificate CE:<br>1404-CPR-3735 |   | ANguar Frame | Combo with bottom rebate,<br>CR compression seal on all four sides<br>and door closer for C5 version |                         | Combo with CR compression seal on 3<br>sides, drop-down seal<br>and door closer for C5 version |                                    |
|--|---|--------------|--|-------------------------|--|------------------------------------|
|  |   |              | CE   | CE C5                   | CE S200/GS<br>CE S 200/GSV   | CE S200/GS C5<br>CE S200/GSV<br>C5 |
| Without<br>window<br><br>  | <b>EN 16034:2014</b>                    |              |  |                         |  |                                    |
|  | Fire resistance                         | ✓            | EI <sub>2</sub> 90   | EI <sub>2</sub> 90      | EI <sub>2</sub> 90   | EI <sub>2</sub> 90                 |
|  | Smoke control                           | ✓            | N.P.D.   | N.P.D.                  | Sa / S200  | Sa / S200                          |
|  | Ability to release / lock               | ✓            | N.P.D.   | N.P.D.                  | N.P.D.   | N.P.D.                             |
|  | Self-closing                            | ✓            | C  | C                       | C  | C                                  |
|  | Durability of release mechanism         | ✓            | N.P.D.   | N.P.D.                  | N.P.D.   | N.P.D.                             |
|  | Durability of self-closing              |              |  |                         |  |                                    |
|  | - against degradation                   | ✓            | 0  | 5                       | 0  | 5                                  |
|  | - against corrosion                     | ✓            | N.P.D.   | N.P.D.                  | N.P.D.   | N.P.D.                             |
|  | <b>EN 14351-1:2006+A2:2016</b>          |              |  |                         |  |                                    |
|  | Air permeability                        | ✓            | 2  | 2                       | 2  | 2                                  |
|  | Water tightness                         | ✓            | 2A   | 2A                      | N.P.D.   | N.P.D.                             |
|  | Wind load resistance                    |              |  |                         |  |                                    |
|  | - Door with FM ≤ 900x2150               | ✓            | C2   | C2                      | N.P.D.   | N.P.D.                             |
|  | - Door with FM > 900x2150               | ✓            | N.P.D.   | N.P.D.                  | N.P.D.   | N.P.D.                             |
|  | Impact resistance                       | ✓            | N.P.D.   | N.P.D.                  | N.P.D.   | N.P.D.                             |
|  | Load-bearing capacity of safety devices | ✓            | Exceeds  | Exceeds                 | Exceeds  | Exceeds                            |
|  | Acoustic performance                    | ✓            | N.P.D.   | N.P.D.                  | N.P.D.   | N.P.D.                             |
|  | Thermal transmittance                   | ✓            | 1,49 W/m <sup>2</sup> K  | 1,49 W/m <sup>2</sup> K | N.P.D.   | N.P.D.                             |
|  | Ability to release / open               | ✓            | N.P.D.   | N.P.D.                  | N.P.D.   | N.P.D.                             |

# Additional performances

UNIVER Fire doors

**NINZ**<sup>®</sup>  
FIRE DOORS

UNIVER  
fire door

| UNIVER Fire Door EI <sub>2</sub> 90<br><br>Certificate CE:<br>1404-CPR-3735 |   | Angular Frame           | Combo with bottom rebate,<br>CR compression seal on all four sides<br>and door closer for C5 version |                         | Combo with CR compression seal on 3<br>sides, drop-down seal<br>and door closer for C5 version |                                 |  |  |
|--|---|-------------------------|--|-------------------------|--|---------------------------------|--|--|
|  |   |                         | CE   | CE C5                   | CE S200/GS<br>CE S 200/GSV   | CE S200/GS C5<br>CE S200/GSV C5 |  |  |
| Without<br>window<br><br><table border="1" data-bbox="139 874 282 1007"> <tr> <td>-</td> <td></td> </tr> </table>  | -   |                         | <b>EN 16034:2014</b>   |                         |  |                                 |  |  |
|  | -   |                         |  |                         |  |                                 |  |  |
|  | Fire resistance                                   | ✓                       | EI <sub>2</sub> 90   | EI <sub>2</sub> 90      | EI <sub>2</sub> 90   | EI <sub>2</sub> 90              |  |  |
|  | Smoke control                                     | ✓                       | N.P.D.   | N.P.D.                  | Sa / S200  | Sa / S200                       |  |  |
|  | Ability to release / lock                         | ✓                       | N.P.D.   | N.P.D.                  | N.P.D.   | N.P.D.                          |  |  |
|  | Self-closing                                      | ✓                       | C  | C                       | C  | C                               |  |  |
|  | Durability of release mechanism                   | ✓                       | N.P.D.   | N.P.D.                  | N.P.D.   | N.P.D.                          |  |  |
|  | Durability of self-closing                        |                         |  |                         |  |                                 |  |  |
|  | - against degradation                             | ✓                       | 0  | 5                       | 0  | 5                               |  |  |
|  | - against corrosion                               | ✓                       | N.P.D.   | N.P.D.                  | N.P.D.   | N.P.D.                          |  |  |
|  | <b>EN 14351-1:2006+A2:2016</b>                    |                         |  |                         |  |                                 |  |  |
|  | Air permeability                                  | ✓                       | 3  | 3                       | 3  | 3                               |  |  |
|  | Water tightness                                   | ✓                       | 3A - 9B  | 3A - 9B                 | N.P.D.   | N.P.D.                          |  |  |
|  | Wind load resistance                              |                         |  |                         |  |                                 |  |  |
|  | - Door with FM ≤ 2000x2150                        | ✓                       | C2   | C2                      | N.P.D.   | N.P.D.                          |  |  |
|  | - Door with FM > 2000x2150                        | ✓                       | N.P.D.   | N.P.D.                  | N.P.D.   | N.P.D.                          |  |  |
|  | Impact resistance                                 | ✓                       | N.P.D.   | N.P.D.                  | N.P.D.   | N.P.D.                          |  |  |
|  | Load-bearing capacity of safety devices           | ✓                       | Exceeds  | Exceeds                 | Exceeds  | Exceeds                         |  |  |
|  | Acoustic performance                              | ✓                       | N.P.D.   | N.P.D.                  | N.P.D.   | N.P.D.                          |  |  |
|  | Thermal transmittance for FM ≤ 3,6 m <sup>2</sup> | ✓                       | 1,88 W/m <sup>2</sup> K  | 1,88 W/m <sup>2</sup> K | N.P.D.   | N.P.D.                          |  |  |
| Thermal transmittance for FM > 3,6 m <sup>2</sup>  | ✓   | 1,51 W/m <sup>2</sup> K | 1,51 W/m <sup>2</sup> K  | N.P.D.                  | N.P.D.   |                                 |  |  |
| Ability to release / open  | ✓   | N.P.D.                  | N.P.D.   | N.P.D.                  | N.P.D.   |                                 |  |  |

✓

# Additional performances

UNIVER Fire doors

**NINZ**<sup>®</sup>  
FIRE DOORS

UNIVER  
fire door

| Essential requirements*  | EN 16034 | EN 14351 |
|--|----------|----------|
| Fire resistance  | YES      | NO       |
| Smoke control  | YES      | NO       |
| Self - closing   | YES      | NO       |
| Durability of performance  | YES      | NO       |
| Thermal insulation   | NO       | YES      |
| Air permeability   | NO       | YES      |
| Water tightness  | NO       | NO       |
| Acoustic performance   | NO       | NO       |
| Wind resistance  | NO       | NO       |
| Load-bearing capacity of safety devices  | NO       | YES      |
| Release/unlocking capability<br>(mandatory for doors installed on escape routes) | NO       | YES      |
| Minimum clear passage height: 2000 mm  | NO       | YES      |

## WARNING

For doors exposed to weather conditions and/or direct sunlight, the customer must take appropriate precautions to prevent long-term deterioration, in particular:

- Canopies or overhangs
- Outdoor paint with UV protection
- Use of light RAL colours to avoid overheating of metal sheets

\* Required under binding national provisions

# Door cross sections - Measurements

UNIVER Fire doors



UNIVER fire door

**One-leaved doors**  
Horizontal cross section

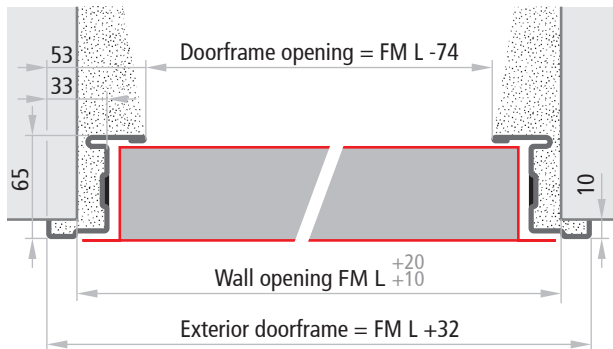

**Doors without lower threshold**  
Vertical cross section

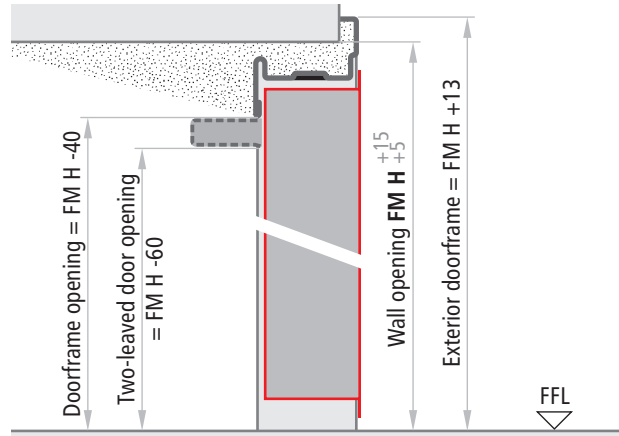

**Doors with internal and external lower thresholds**  
Vertical cross section

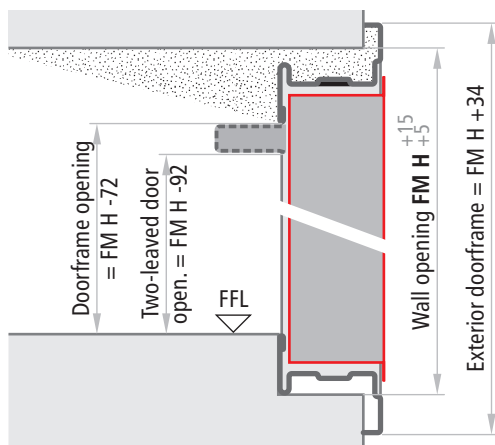

**Doors with internal lower threshold**  
Vertical cross section

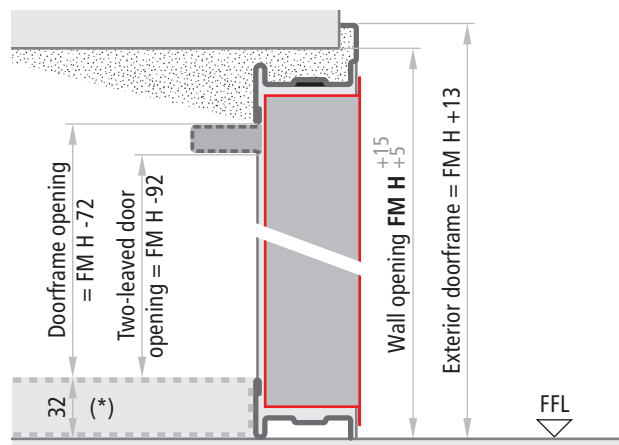

**Two-leaved doors**  
Horizontal section

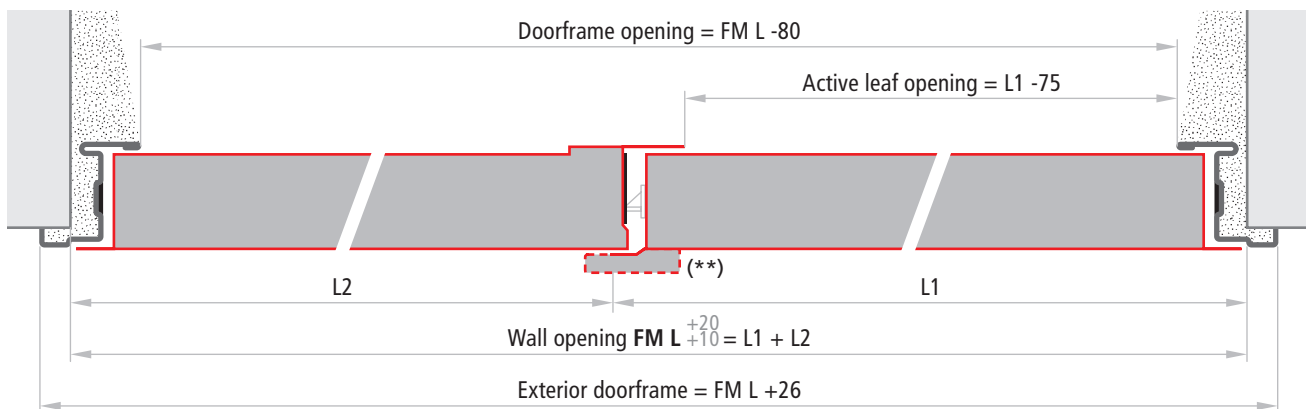

**Leaves thickness**

|            |       |
|------------|-------|
| Fire doors | 60 mm |
|------------|-------|

**NOTE**

The tolerances FM L <sup>+20</sup>/<sub>+10</sub>, FM H <sup>+15</sup>/<sub>+5</sub> of the indicated measurements make it easier to fill the gap between the wall and the doorframe with cement mortar.

(\*) Shimming to be done, mandatory in case of installation onto emergency exit routes.

(\*\*) Only for EI<sub>2</sub>90 fire rated doors

# Installation methods

UNIVER Fire doors

## INSTALLATION WITH ANCHORS FOR MORTAR FIXING

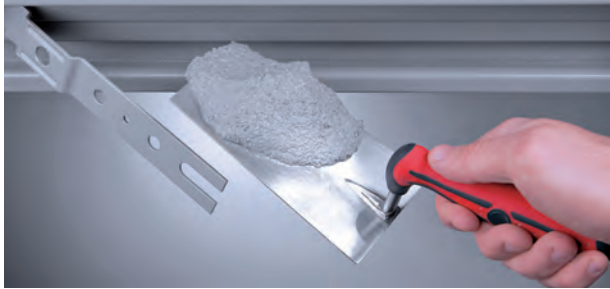

For mortar fixing, appropriate cuts will need to be created in the walls (section 80 x 200 mm). The anchors should be bent and blocked inside the wall. For fire sealing purposes and a perfect mechanical fit, the space between the door-frame and the masonry shall always be filled with concrete mortar.

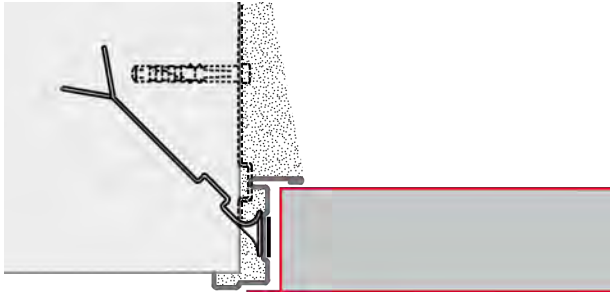

## INSTALLATION FOR EXPANSION SCREWS FIXING

For the installation with expansion screws, the anchors serve as spacers and should not be bent. Using Würth type art. 0910436112 plugs or similar (supplied at the customer's expense), installation requires holes to be drilled through the thermo expansive sealing. The doorframe has pre-drilled holes. For fire sealing purposes and a perfect mechanical fit, the space between the doorframe and the masonry shall always be filled with concrete mortar.

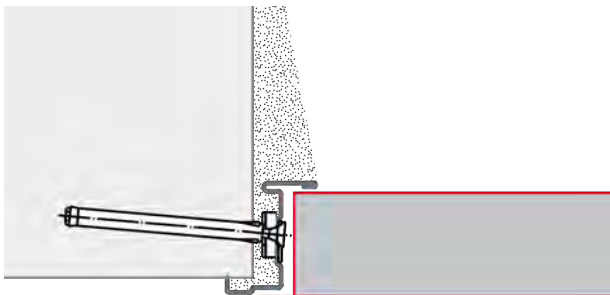

## ANCHOR POSITIONING

### One-leaved doors

Right opening

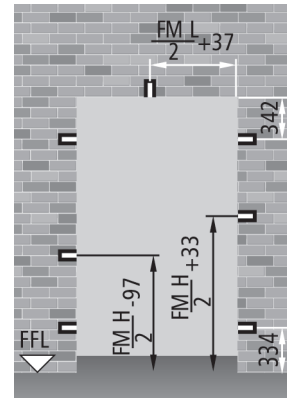

Left opening

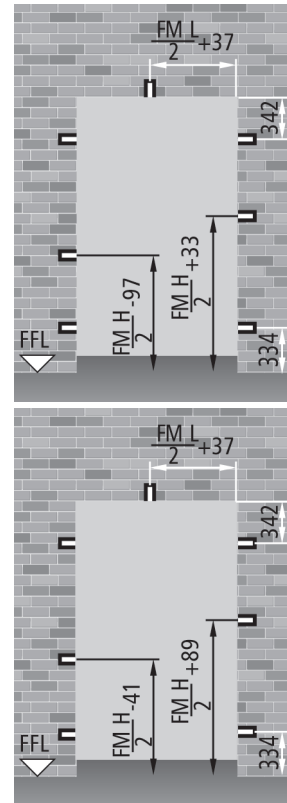

### Two-leaved doors

Right opening

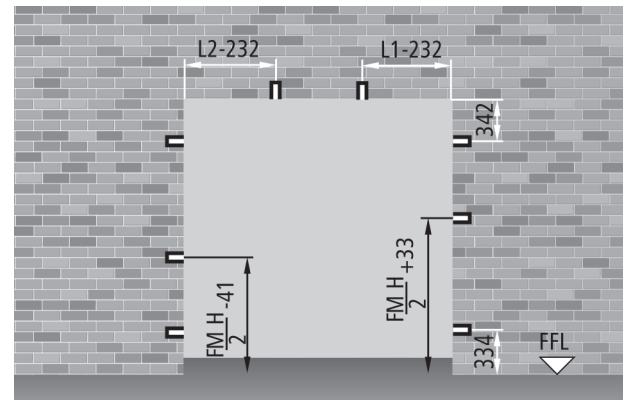

Left opening

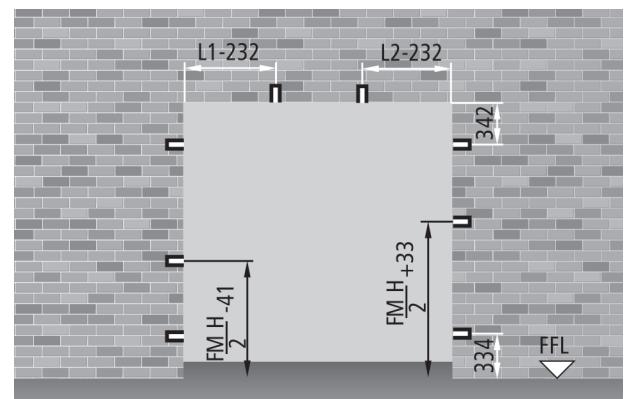

# Order measurements

UNIVER Fire doors



UNIVER  
fire door

## ORDER MEASUREMENTS

### Wall opening

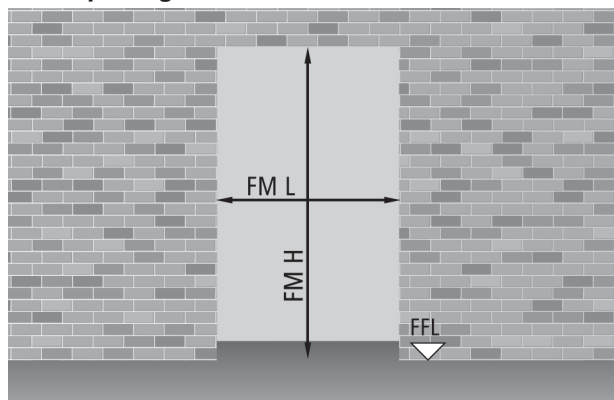

### Doorframe opening

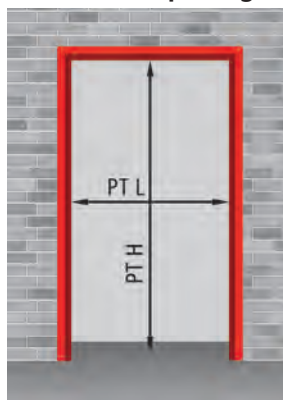

### E 60 one-leaved doors FM L x FM H

### PT L x PT H

### fire-rating

| standard dimensions |   |                    | doorframe opening |                      | class |
|---------------------|---|--------------------|-------------------|----------------------|-------|
| 800                 | x | 2050 / 2100 / 2150 | 726               | x 2010 / 2060 / 2110 | E 60  |
| 900                 | x | 2050 / 2100 / 2150 | 826               | x 2010 / 2060 / 2110 | E 60  |
| 1000                | x | 2050 / 2100 / 2150 | 926               | x 2010 / 2060 / 2110 | E 60  |
| 1100                | x | 2050 / 2100 / 2150 | 926               | x 2010 / 2060 / 2110 | E 60  |

#### non-standard dimensions

|                  |   |                   |                  |                     |      |
|------------------|---|-------------------|------------------|---------------------|------|
| from 540 to 1150 | x | from 1780 to 2150 | from 466 to 1076 | x from 1740 to 2110 | E 60 |
|------------------|---|-------------------|------------------|---------------------|------|

### EI one-leaved doors FM L x FM H

### PT L x PT H

### fire-rating

| standard dimensions |   |                    | doorframe opening |                      | class                                  |
|---------------------|---|--------------------|-------------------|----------------------|--|
| 800                 | x | 2050 / 2100 / 2150 | 726               | x 2010 / 2060 / 2110 | EI <sub>2</sub> 60, EI <sub>2</sub> 90 |
| 900                 | x | 2050 / 2100 / 2150 | 826               | x 2010 / 2060 / 2110 | EI <sub>2</sub> 60, EI <sub>2</sub> 90 |
| 1000                | x | 2050 / 2100 / 2150 | 926               | x 2010 / 2060 / 2110 | EI <sub>2</sub> 60, EI <sub>2</sub> 90 |
| 1100                | x | 2050 / 2100 / 2150 | 1026              | x 2010 / 2060 / 2110 | EI <sub>2</sub> 60                     |

#### non-standard dimensions

|                  |   |                   |                  |                     |                    |
|------------------|---|-------------------|------------------|---------------------|--------------------|
| from 540 to 1150 | x | from 1780 to 2150 | from 466 to 1076 | x from 1740 to 2110 | EI <sub>2</sub> 60 |
| from 540 to 1000 | x | from 1780 to 2150 | from 466 to 926  | x from 1740 to 2110 | EI <sub>2</sub> 90 |

### REI one-leaved doors FM L x FM H

### PT L x PT H

### fire-rating

| standard dimensions |   |                    | doorframe opening |                      | class   |
|---------------------|---|--------------------|-------------------|----------------------|---------|
| 800                 | x | 2050 / 2100 / 2150 | 726               | x 2010 / 2060 / 2110 | REI 120 |
| 900                 | x | 2050 / 2100 / 2150 | 826               | x 2010 / 2060 / 2110 | REI 120 |
| 1000                | x | 2050 / 2100 / 2150 | 926               | x 2010 / 2060 / 2110 | REI 120 |
| 1100                | x | 2050 / 2100 / 2150 | 1026              | x 2010 / 2060 / 2110 | REI 120 |
| 1200                | x | 2050 / 2100 / 2150 | 1126              | x 2010 / 2060 / 2110 | REI 120 |
| 1300                | x | 2050 / 2100 / 2150 | 1226              | x 2010 / 2060 / 2110 | REI 120 |
| 1350                | x | 2050 / 2100 / 2150 | 1276              | x 2010 / 2060 / 2110 | REI 120 |

#### non-standard dimensions

|                  |   |                   |                  |                     |         |
|------------------|---|-------------------|------------------|---------------------|---------|
| from 540 to 1350 | x | from 1780 to 2150 | from 466 to 1276 | x from 1740 to 2110 | REI 120 |
|------------------|---|-------------------|------------------|---------------------|---------|

# Order measurements

## UNIVER Fire doors

| EI two-leaved doors FM L x FM H |                |   |                    | PT L x PT H                          | H net passage          | fire-rating                            |
|---------------------------------|----------------|---|--------------------|--------------------------------------|------------------------|--|
| standard dimensions             |                |   |                    | doorframe opening                    | for RC/STD encumbrance | class                                  |
| 1200                            | ( 600 + 600)   | x | 2050 / 2100 / 2150 | 1120 x 2010 / 2060 / 2110            | 1990 / 2040 / 2090     | EI <sub>2</sub> 60                     |
| 1200                            | ( 700 + 500)   | x | 2050 / 2100 / 2150 | 1120 x 2010 / 2060 / 2110            | 1990 / 2040 / 2090     | EI <sub>2</sub> 60                     |
| 1300                            | ( 650 + 650)   | x | 2050 / 2100 / 2150 | 1220 x 2010 / 2060 / 2110            | 1990 / 2040 / 2090     | EI <sub>2</sub> 60                     |
| 1300                            | ( 800 + 500)   | x | 2050 / 2100 / 2150 | 1220 x 2010 / 2060 / 2110            | 1990 / 2040 / 2090     | EI <sub>2</sub> 60, EI <sub>2</sub> 90 |
| 1400                            | ( 700 + 700)   | x | 2050 / 2100 / 2150 | 1320 x 2010 / 2060 / 2110            | 1990 / 2040 / 2090     | EI <sub>2</sub> 60                     |
| 1400                            | ( 900 + 500)   | x | 2050 / 2100 / 2150 | 1320 x 2010 / 2060 / 2110            | 1990 / 2040 / 2090     | EI <sub>2</sub> 60, EI <sub>2</sub> 90 |
| 1500                            | ( 750 + 750)   | x | 2050 / 2100 / 2150 | 1420 x 2010 / 2060 / 2110            | 1990 / 2040 / 2090     | EI <sub>2</sub> 60                     |
| 1500                            | ( 1000 + 500)  | x | 2050 / 2100 / 2150 | 1420 x 2010 / 2060 / 2110            | 1990 / 2040 / 2090     | EI <sub>2</sub> 60, EI <sub>2</sub> 90 |
| 1600                            | ( 800 + 800)   | x | 2050 / 2100 / 2150 | 1520 x 2010 / 2060 / 2110            | 1990 / 2040 / 2090     | EI <sub>2</sub> 60, EI <sub>2</sub> 90 |
| 1700                            | ( 900 + 800)   | x | 2050 / 2100 / 2150 | 1620 x 2010 / 2060 / 2110            | 1990 / 2040 / 2090     | EI <sub>2</sub> 60, EI <sub>2</sub> 90 |
| 1800                            | ( 900 + 900)   | x | 2050 / 2100 / 2150 | 1720 x 2010 / 2060 / 2110            | 1990 / 2040 / 2090     | EI <sub>2</sub> 60, EI <sub>2</sub> 90 |
| 1900                            | ( 1000 + 900)  | x | 2050 / 2100 / 2150 | 1820 x 2010 / 2060 / 2110            | 1990 / 2040 / 2090     | EI <sub>2</sub> 60, EI <sub>2</sub> 90 |
| 2000                            | ( 1000 + 1000) | x | 2050 / 2100 / 2150 | 1920 x 2010 / 2060 / 2110            | 1990 / 2040 / 2090     | EI <sub>2</sub> 60, EI <sub>2</sub> 90 |
| <b>non-standard dimensions</b>  |                |   |                    |                                      |                        |  |
| from 1000 ( 500+ 500)           |                | x | from 1780 to 2150  | from 920 to 1920 x from 1740 to 2110 | from 1720 to 2090      | EI <sub>2</sub> 60, EI <sub>2</sub> 90 |

| REI two-leaved doors FM L x FM H |                |   |                    | PT L x PT H                          | H net passage          | fire-rating |
|----------------------------------|----------------|---|--------------------|--------------------------------------|------------------------|-------------|
| standard dimensions              |                |   |                    | doorframe opening                    | for RC/STD encumbrance | class       |
| 1150                             | ( 750 + 400)   | x | 2050 / 2100 / 2150 | 1070 x 2010 / 2060 / 2110            | 1990 / 2040 / 2090     | REI 120     |
| 1200                             | ( 800 + 400)   | x | 2050 / 2100 / 2150 | 1120 x 2010 / 2060 / 2110            | 1990 / 2040 / 2090     | REI 120     |
| 1250                             | ( 800 + 450)   | x | 2050 / 2100 / 2150 | 1170 x 2010 / 2060 / 2110            | 1990 / 2040 / 2090     | REI 120     |
| 1300                             | ( 900 + 400)   | x | 2050 / 2100 / 2150 | 1220 x 2010 / 2060 / 2110            | 1990 / 2040 / 2090     | REI 120     |
| 1350                             | ( 900 + 450)   | x | 2050 / 2100 / 2150 | 1270 x 2010 / 2060 / 2110            | 1990 / 2040 / 2090     | REI 120     |
| 1400                             | ( 1000 + 400)  | x | 2050 / 2100 / 2150 | 1320 x 2010 / 2060 / 2110            | 1990 / 2040 / 2090     | REI 120     |
| 1450                             | ( 1000 + 450)  | x | 2050 / 2100 / 2150 | 1370 x 2010 / 2060 / 2110            | 1990 / 2040 / 2090     | REI 120     |
| 1600                             | ( 800 + 800)   | x | 2050 / 2100 / 2150 | 1520 x 2010 / 2060 / 2110            | 1990 / 2040 / 2090     | REI 120     |
| 1700                             | ( 900 + 800)   | x | 2050 / 2100 / 2150 | 1620 x 2010 / 2060 / 2110            | 1990 / 2040 / 2090     | REI 120     |
| 1800                             | ( 900 + 900)   | x | 2050 / 2100 / 2150 | 1720 x 2010 / 2060 / 2110            | 1990 / 2040 / 2090     | REI 120     |
| 1900                             | ( 1000 + 900)  | x | 2050 / 2100 / 2150 | 1820 x 2010 / 2060 / 2110            | 1990 / 2040 / 2090     | REI 120     |
| 2000                             | ( 1000 + 1000) | x | 2050 / 2100 / 2150 | 1920 x 2010 / 2060 / 2110            | 1990 / 2040 / 2090     | REI 120     |
| <b>non-standard dimensions</b>   |                |   |                    |                                      |                        |             |
| from 940 ( 540+ 400)             |                | x | from 1780 to 2150  | from 920 to 1920 x from 2011 to 2110 | from 1720 to 2090      | REI 120     |

### NOTE

Unless specified otherwise by the customer, two-leaved doors are supplied with a right-pull opening direction.

# Opening measurements - Overall dimensions

UNIVER Fire doors



UNIVER fire door

## OPENING MEASUREMENTS AND OVERALL DIMENSIONS WITH 90 DEGREE OPENING

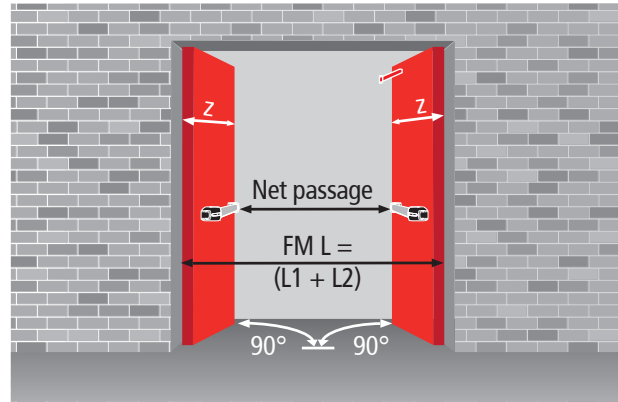
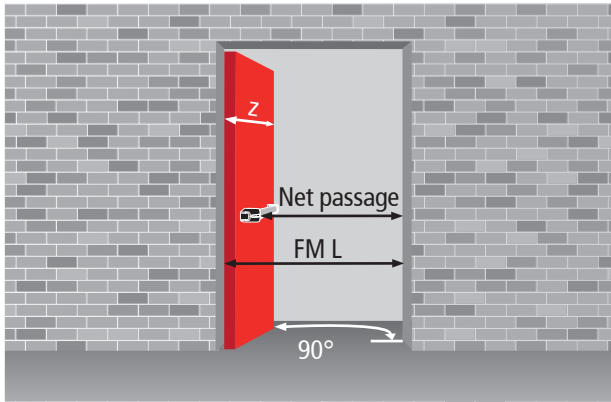

### Net passage calculation

| panic bar type                           |  | protrusion | E 60             | EI <sub>2</sub> 60 - EI <sub>2</sub> 90 - REI 120 | EI <sub>2</sub> 60 - EI <sub>2</sub> 90 - REI 120 |
|--|--|------------|------------------|---|---|
|  |  |            | one-leaved doors | one-leaved doors                                  | two-leaved doors                                  |
| EXUS                                     |  | 125        | FML - 226        | FML - 236   | FML - 404   |
| TWIST                                    |  | 100        | FML - 201        | FML - 211   | FML - 354   |
| SLASH                                    |  | 75         | FML - 176        | FML - 186   | FML - 304   |
| FAST TOUCH                               |  | 75         | FML - 176        | FML - 186   | FML - 304   |
| without panic bar                        |  | -          | FML - 101        | FML - 111   | FML - 154   |
| z = leaf protrusion relative to the wall |  |            | FML + 29         | FML + 29  | L1 + 35<br>L2 + 64                                |

## OVERALL DIMENSIONS WITH 180 DEGREE OPENING - HANDLE HEIGHT

### One-leaved doors

$x = FML + 5$   
 $h \text{ handle} = FMH/2 + 50$

### Two-leaved doors

$x = L1 + 5$      $y = L2 + 35$   
 $h \text{ handle} = FMH/2 + 50$   
 $b = 130$  (only in the presence of panic bars or M14 handles)

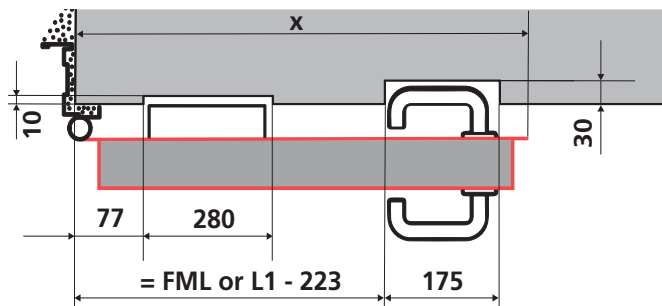
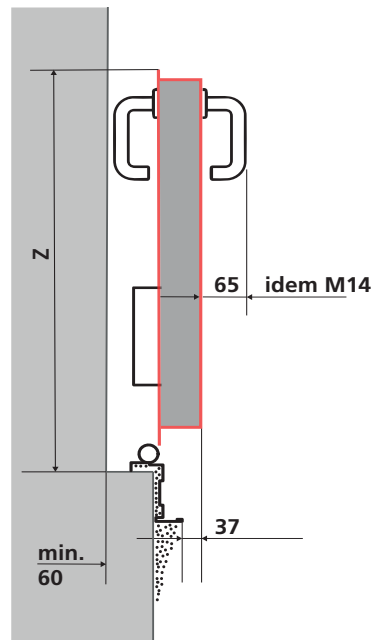
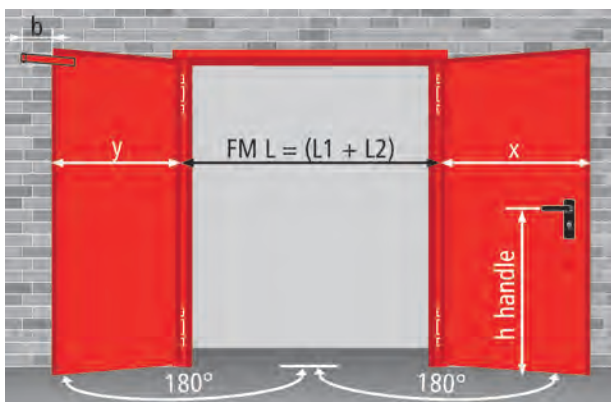
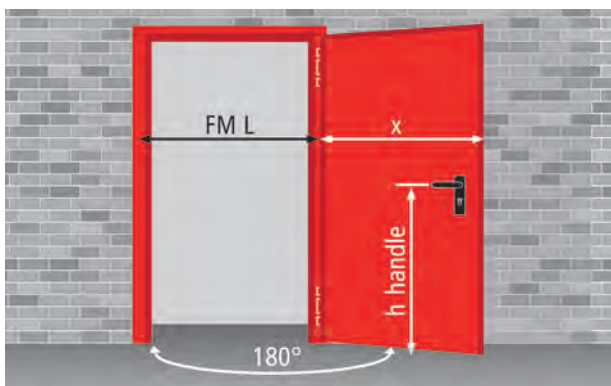

**"fire protection excellence,  
flexibility custom-made"**



# PROGET NINZ Doors

*FIRE RATED VERSION*

|   |         |
|---|---------|
| FEATURES                                  | 30 - 33 |
| SPECIFIC OPTIONAL ACCESSORIES             | 34 - 39 |
| ADDITIONAL PERFORMANCES                   | 40 - 51 |
| DOOR CROSS SECTIONS - MEASUREMENTS        | 52      |
| STANDARD INSTALLATION METHOD              | 53      |
| OPTIONAL INSTALLATION METHODS             | 54 - 55 |
| LIGHTWEIGHT CONSTRUCTIONS INSTALLATION    | 56      |
| ORDER MEASUREMENTS, HANDLE HEIGHT         | 58      |
| OPENING MEASUREMENTS - OVERALL DIMENSIONS | 59      |

**THE FIRE DOOR IN A CLASS OF ITS OWN**

**“Indisputable quality”**

- Especially sturdy door for safe functioning over time
- Ideal for application to uneven or weak walls
- Fully isolated frame for true “dry wall installation”
- Built to order for all kinds of requests
- Fully galvanized door, including the “hidden” parts
- Made of hot-galvanized sheet metal, “Sendzimir” processed
- Corrosion protection also provided along cut edges of the metal sheets
- Painted with epoxy-polyester thermoset powders in a 180 degrees (Celsius) oven
- Substantial paint layer (70 microns plus)
- Optimal corrosion resistance demonstrated by 500 hour salt-fog test
- Unaffected by severe climate changes, demonstrated by 2000 hours with +60° to -10° cycles at 75% humidity
- Finishing with high-quality aesthetics
- Orange skin anti-scratch structured paint
- Customizable with wide selection of RAL colors

**“Practicality of use”**

- Truly sturdy frame that facilitates anchoring to the wall
- Suitable for all wall types
- Different installation methods to choose from
- Significantly reduced installation times
- Type approvals for multiple installations to different wall types
- Ample size range
- Wide variety of accessories

**“Conformity to standards”**

- In-house Ninz R&D with specialized testing equipment
- Fire testing in accordance with UNI 9723 and EN 1634-1
- Mechanical testing for the **CE** marking of accessories
- **CE** marked door accessories studied and sized to meet standard European requirements
- Careful selection of materials and manufacturing methods
- Strict product testing for conformity to declared technical standards
- Absolute functional certainty over time
- Doors “type approved” in compliance with M.D. 21 June 2004
- Products delivered with the documentation required by current regulations

**“Manufacturing technology”**

- Manufacturing in modern and functional facilities which employ the latest technologies to maintain high quality levels and product uniformity
- The entire production process - from raw materials to painted and packaged products - takes place inside Ninz’s own facilities, ensuring a 360 degree door control

**Opening direction**

Opening direction needs to be indicated while ordering

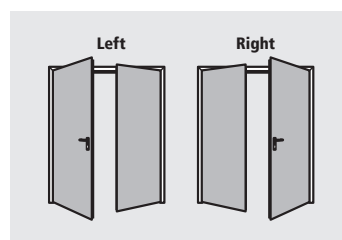
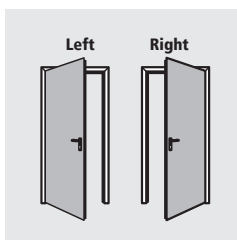

One-leaved doors available in the following classes:

🔥 EI<sub>2</sub>60 🔥 EI<sub>2</sub>120 🔥 REI 60 🔥 REI 120 🔥 EI<sub>2</sub> 60 CE 🔥 EI<sub>2</sub>120 CE



Two-leaved doors available in the following classes:

🔥 EI<sub>2</sub>60 🔥 EI<sub>2</sub>90 🔥 REI 60 🔥 REI 120 🔥 EI<sub>2</sub> 60 CE 🔥 EI<sub>2</sub>90 CE



## STANDARD ELEMENTS

### Door leaf

- Made of "Sendzimir" processed hot-galvanized sheet metal, press folded and electro welded
- Perimetral rebate on 3 sides, flat at the bottom
- Internally reinforced with hot-galvanized steel profiles
- Heat-insulated treated mineral wool packing that is rigidly joined to the sheet metal
- Internal stiffeners for overhead door closer and panic bar

### Standard frame

- Sturdy profile with a sizeable cross section
- Made of "Sendzimir" processed hot-galvanized sheet metal
- Equipped with special assembly brackets
- Grooves for thermo expansive sealing and rebate sealing
- Standard installation via anchors for mortar fixing
- Upon request installation via expansion screws or screws onto the subframe
- Lower spacer, mounting template
- Rests on finished flooring without rebate
- Strike plates in black plastic for lock bolt and safety bolts
- Assembly required for doorframes

### Thermo expansive sealing

- Mounted on vertical doorframe profiles and central vertical profiles (for two-leaved doors)
- Mounted above and below the leaves depending on the certification



### Hinges

- Nr. 2 three-wing hinges for each leaf
- of which one ball-bearing hinge with screws for vertical adjustment of the leaf, **CE** marked as per EN 1935, classified for up to 160 kg load, 200.000 cycles durability, suitable for fire door use
- and one hinge with self-closing spring

### Safety bolts

- Nr. 1 or 2 or 3 safety bolts applied on hinge side leaf edge



### Locking mechanism

- Reversible locking mechanism with bolt and central latch for EI<sub>2</sub>60, EI<sub>2</sub>90 REI 60 and REI 120 doors
- Three locking point mechanism for one-leaved EI<sub>2</sub>120 doors
- **CE** marked in conformity with EN 12209 standard
- Insert with patent key, Euro profile cylinder ready

### Handle

- Fire rated handle in black plastic with steel core
- Steel installation plate with cylinder hole
- Cover plate in black plastic
- Fastener screws and patent key insert

**INCLUDED ACCESSORIES**

**Closing regulator**

- Standard two-leaved doors include an RC/STD closing regulator to ensure the correct closing sequence of the leaves, except those with environmental characteristics for which the RC2 system is mandatory (to be ordered with the door).
- CE marking in conformity with EN 1158 standard

**Locking mechanism for inactive leaf**

- "Flush-bolt" automatic locking of the inactive leaf
- Lever control for unlocking

**Upper coupling system for the inactive leaf**

- Inactive leaf lock activated device which inserts rod into the upper strike box
- Upper strike box in pierced steel with steel roller

**Lower coupling system for the inactive leaf**

- Vertical rod with steel point which inserts into lower strike box
- Lower floor catch (floor-mounted bushing) made of self-extinguishing black plastic with rebate stopper

**Identification plate**

- Metal tag with door identification data, in accordance with current regulations



Standard paint - group 01: RAL 9010

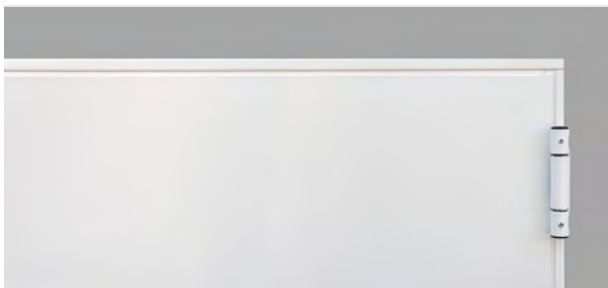

**Finishing**

- Standard painted with epoxy-polyester thermoset powders in a 180 degrees oven, orange skin, anti-scratch finishing
- Standard paint RAL 9010

**Standard packaging**

- Single leaf wrapped into stretchable polyethylene (PE) film
- Single packaging for each doorframe with stretchable polyethylene (PE) film
- Palletized on wooden pallets

**NOTE**

If the door ever needs to be repainted, follow the precise instructions on the "Painting" section.

**INSTALLATION ONTO OTHER WALL TYPES**

Other types of installation are possible, all of which have been rigorously certified and approved

- Frame for dry wall installation with expansion screws
- Frame for dry wall installation with screws onto the sub-frame
- Block frame for in the reveal application
- Embracing frame for lightweight constructions installation



**OPTIONAL ACCESSORIES**

A wide variety of accessories and surface finishes are available on request for maximum value enhancement of Proget doors to your own specific needs. The proper accessories can help resolve:

**Safety-related needs**

- Doors for panic exits (see panic bars)
- Doors for emergency exits (see emergency exit handles)
- Open doors which must be closed in case of fire (see leaf holding systems)

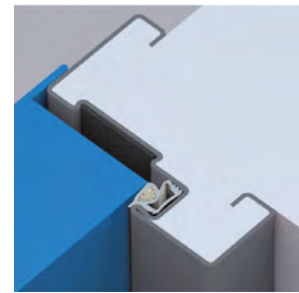

**Installation and utilization needs**

- Frame extensions
- Different kinds of floor mounted catches
- Roofing and drip steel-profile
- Special fastener screws
- Kick and protection plates in stainless steel
- Rectangular windows, standard dimensions or built to order
- Round windows
- One-leaved door with frame on four sides



**Access-related control issues**

- Electrically-activated lock mechanisms
- Electric handle mechanisms
- Magnetic blocking mechanisms

**Performance enhancing**

- Sealing
- Cylinders
- Door closers
- Special closing regulators
- Special handles

**Customized finishing**

- Select finishing from a wide variety of RAL colours
- NDD – Ninz Digital Decor, graphic images applied with special ink jets and protected by a transparent topcoat. Infinite varieties of customizable decorations in harmony with specific door settings
- Stainless steel handles
- Colored handles

**Packaging for maximum protection**

Sturdy wooden crates protect all doors and related accessories

- For NDD decorated doors
- On construction sites
- During shipping abroad
- For special transport

**NOTE**

Details on the optional accessories may be found in the following chapters of this brochure:

- Painting and NDD decorations
- Accessories for metal doors
- Emergency handles and panic bars



# Specific optional accessories

PROGET Fire doors

**NINZ**<sup>®</sup>  
FIREDOORS

PROGET  
fire doors

## WINDOW WITH FIRE RATED GLASS

Upon request all one- and two-leaved fire doors may be equipped with round or rectangular windows with fire rated stratified glass and respective window frames fixed with screws. The window frame carters are included for round window and available as an optional accessory for the rectangular one.

### Limits prescribed by regulations

According to standards UNI 9723 and EN 1634-1, windows may be smaller but not larger than the test sample size, and the reverse holds true for the border strip around the window which may be wider but not thinner. The following limits correspond with these restrictions.

### Borders, window position

"Border measurement" refers to the distance from the edge of the window to the wall opening of the door.



### Elevation for round windows

| window size | FM H              | position     |
|-------------|-------------------|--------------|
| Ø 300       | minimum 2050      | Y=1600       |
| Ø 300       | less than 2050    | Y=FM H - 450 |
| Ø 400       | minimum 2150      | Y=1600       |
| Ø 400       | from 2050 to 2149 | Y=1550       |
| Ø 400       | less than 2050    | Y=FM H - 500 |

### Elevation for rectangular windows

| window dimensions L x H | FM H              | position      |
|-------------------------|-------------------|---------------|
| 300 x 400               | minimum 2150      | Z=1450        |
| 300 x 400               | from 2050 to 2149 | Z=1350        |
| 300 x 400               | less than 2050    | Z=FM H - 700  |
| 400 x 600               | minimum 2150      | Z=1250        |
| 400 x 600               | from 2050 to 2149 | Z=1150        |
| 400 x 600               | less than 2050    | Z=FM H - 900  |
| 400 x 1200              | minimum 2150      | Z=650         |
| 400 x 1200              | from 2050 to 2149 | Z=550         |
| 400 x 1200              | less than 2050    | Z=FM H - 1500 |

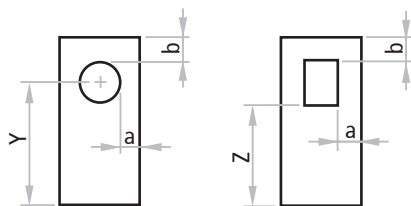

### NOTE

Position and measurements indicated above are those standard.

Different positions and measurements may be considered as long as they respect the minimum "a" and "b" border strips and maximal measurements mentioned in the certificate for the window. The window itself may not be supplied separately except for replacements. It is always advisable for doors with windows to be equipped with door closers for controlled closing.

### NOTE

For the rectangular windows the frame carters are an optional accessory

### Round window cross section

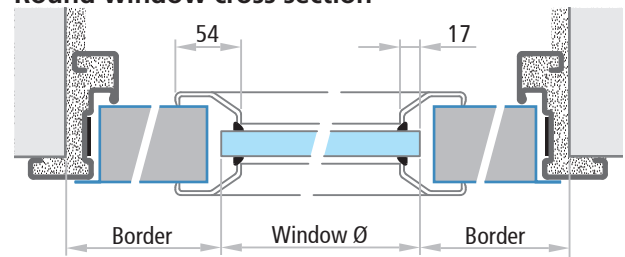

### Rectangular window cross section

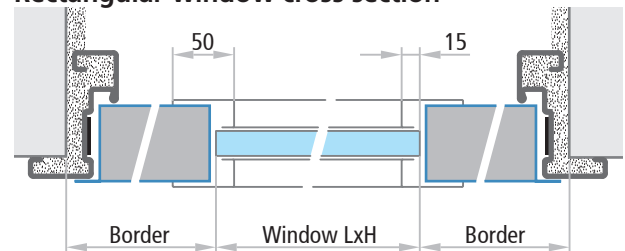

### ATTENTION

For special instructions and recommendations for glazed fire-rated products, see the "Notices" section on the last page of the present brochure.

# Specific optional accessories

PROGET Fire doors



## EI WINDOW SPECIFICATIONS BASED ON INSTALLATION METHOD

| model | min./max. window |   |                 | border strip |     | mortar fixing | expansion screws | lightweight constructions with embracing frame | block frame | EI,60 | EI,90 | EI,120 | dimensions FM L (L1 + L2) x FM H                                  |
|-------|------------------|---|-----------------|--------------|-----|---------------|------------------|--|-------------|-------|-------|--------|---|
|       | L                | x | H               | a            | b   |               |                  |  |             |       |       |        |   |
|       | Ø 300            |   |                 | 300          | 300 | ✓             | ✓                | ✓  | ✓           | ✓     |       |        | from 900 to 1340 x from 1950 to 2600                              |
|       | Ø 400            |   |                 | 300          | 300 | ✓             | ✓                | ✓  | ✓           | ✓     |       |        | from 1000 to 1340 x from 1950 to 2600                             |
|       | Ø 300            |   |                 | 300          | 300 | ✓             | ✓                |  | ✓           |       | ✓     |        | from 900 to 1340 x from 1900 to 2640                              |
|       | Ø 400            |   |                 | 300          | 300 | ✓             | ✓                |  | ✓           |       | ✓     |        | from 1000 to 1340 x from 1900 to 2640                             |
|       | from 250 to 700  |   | from 250 to 650 | 300          | 300 | ✓             | ✓                | ✓  |             | ✓     |       |        | from 850 to 1340 x from 1950 to 2600                              |
|       | from 250 to 670  |   | from 250 to 620 | 300          | 300 |               |                  |  | ✓           | ✓     |       |        | from 850 to 1340 x from 1950 to 2600                              |
|       | from 250 to 600  |   | from 250 to 400 | 370          | 300 | ✓             | ✓                |  | ✓           |       | ✓     |        | from 990 to 1340 x from 1900 to 2640                              |
|       | Ø 300            |   |                 | 300          | 300 | ✓             | ✓                | ✓  | ✓           | ✓     |       |        | from 1250 ( 900 + 350) to 2540 (1270 + 1270) x from 1775 to 2600  |
|       | Ø 400            |   |                 | 300          | 300 | ✓             | ✓                | ✓  | ✓           | ✓     |       |        | from 1350 (1000 + 350) to 2540 (1270 + 1270) x from 1775 to 2600  |
|       | Ø 300            |   |                 | 300          | 300 | ✓             | ✓                |  | ✓           |       | ✓     |        | from 1475 ( 900 + 575) to 2270 (1150 + 1120) x from 1775 to 2300  |
|       | Ø 400            |   |                 | 300          | 300 | ✓             | ✓                |  | ✓           |       | ✓     |        | from 1575 (1000 + 575) to 2270 (1150 + 1120) x from 1775 to 2300  |
|       | Ø 300            |   |                 | 300          | 300 | ✓             | ✓                | ✓  | ✓           | ✓     |       |        | from 1800 ( 900 + 900) to 2540 (1270 + 1270) x from 1775 to 2600  |
|       | Ø 400            |   |                 | 300          | 300 | ✓             | ✓                | ✓  | ✓           | ✓     |       |        | from 2000 (1000 + 1000) to 2540 (1270 + 1270) x from 1775 to 2600 |
|       | Ø 300            |   |                 | 300          | 300 | ✓             | ✓                |  | ✓           |       | ✓     |        | from 1800 ( 900 + 900) to 2270 (1150 + 1120) x from 1775 to 2300  |
|       | Ø 400            |   |                 | 300          | 300 | ✓             | ✓                |  | ✓           |       | ✓     |        | from 2000 (1000 + 1000) to 2270 (1150 + 1120) x from 1775 to 2300 |
|       | from 250 to 700  |   | from 250 to 650 | 300          | 300 | ✓             | ✓                | ✓  |             | ✓     |       |        | from 1200 ( 850 + 350) to 2540 (1270 + 1270) x from 1775 to 2600  |
|       | from 250 to 670  |   | from 250 to 620 | 300          | 300 |               |                  |  | ✓           | ✓     |       |        | from 1200 ( 850 + 350) to 2540 (1270 + 1270) x from 1775 to 2600  |
|       | from 250 to 600  |   | from 250 to 400 | 300          | 300 | ✓             | ✓                |  | ✓           |       | ✓     |        | from 1425 ( 850 + 575) to 2270 (1150 + 1120) x from 1775 to 2300  |
|       | from 250 to 700  |   | from 250 to 650 | 300          | 300 | ✓             | ✓                | ✓  |             | ✓     |       |        | from 1700 ( 850 + 850) to 2540 (1270 + 1270) x from 1775 to 2600  |
|       | from 250 to 670  |   | from 250 to 620 | 300          | 300 |               |                  |  | ✓           | ✓     |       |        | from 1700 ( 850 + 850) to 2540 (1270 + 1270) x from 1775 to 2600  |
|       | from 250 to 600  |   | from 250 to 400 | 300          | 300 | ✓             | ✓                |  | ✓           |       | ✓     |        | from 1700 ( 850 + 850) to 2270 (1150 + 1120) x from 1775 to 2300  |

For external EI fire-rated doors with CE marking, it is not possible to choose round vision panels or a casing frame.

PROGET fire doors

















# Specific optional accessories

PROGET Fire doors

**NINZ**  
FIREDOORS

PROGET  
fire doors

## REI WINDOW SPECIFICATIONS BASED ON INSTALLATION METHOD

| model   | min./max. window   |                     |     | border strip |     | mortar fixing<br>subframe | expansion screws | plasterboard with<br>embracing frame | REI 60 | REI 120 | dimensions FM L (L1 + L2) x FM H   |
|---|--------------------|---------------------|-----|--------------|-----|---------------------------|------------------|--------------------------------------|--------|---------|--|
|   | L                  | x                   | H   | a            | b   |                           |                  |                                      |        |         |  |
|    | Ø 300              |                     |     | 300          | 300 |                           | ✓                | ✓                                    | ✓      | ✓       | from 900 to 1170 x from 1775 to 2275<br>from 1004 to 1340 x from 2050 to 2500  |
|   | Ø 400              |                     |     | 300          | 300 |                           | ✓                | ✓                                    | ✓      | ✓       | from 1000 to 1170 x from 1775 to 2275<br>from 1004 to 1340 x from 2050 to 2500   |
|    | from 250<br>to 400 | from 250<br>to 600  | 250 | 300          | ✓   |                           |                  |                                      |        | ✓       | from 750 to 900 x from 1775 to 2000  |
|    | from 250<br>to 400 | from 250<br>to 600  | 300 | 300          | ✓   |                           |                  |                                      |        | ✓       | from 850 to 1000 x from 1775 to 2150   |
|    | from 250<br>to 620 | from 250<br>to 400  | 360 | 300          | ✓   |                           |                  |                                      |        | ✓       | from 970 to 1340 x from 1775 to 2670   |
|    | from 250<br>to 564 | from 250<br>to 443  | 300 | 300          |     | ✓                         | ✓                | ✓                                    | ✓      | ✓       | from 850 to 1170 x from 1775 to 2275<br>from 1004 to 1340 x from 2050 to 2500  |
|  | from 250<br>to 400 | from 630<br>to 1400 | 250 | 300          | ✓   |                           |                  |                                      |        | ✓       | from 750 to 900 x from 1775 to 2000<br>from 779 to 1037 x from 1803 to 2197  |
|  | from 250<br>to 522 | from 500<br>to 1460 | 320 | 300          | ✓   |                           |                  |                                      |        | ✓       | from 890 to 1162 x from 1775 to 2620<br>from 997 to 1332 x from 2361 to 2670   |
|  | Ø 300              |                     |     | 300          | 300 |                           | ✓                | ✓                                    | ✓      | ✓       | from 1250 ( 900 + 350) to 2252 (1126 + 1126) x from 1775 to 2275**<br>from 1962 ( 996 + 966) to 2540 (1270 + 1270) x from 2050 to 2500 |
|   | Ø 400              |                     |     | 300          | 300 |                           | ✓                | ✓                                    | ✓      | ✓       | ✓  |
|  | Ø 300              |                     |     | 300          | 300 |                           | ✓                | ✓                                    | ✓      | ✓       | from 1800 ( 900 + 900) to 2252 (1126 + 1126) x from 1775 to 2275<br>from 1962 ( 996 + 966) to 2540 (1270 + 1270) x from 2050 to 2500   |
|   | Ø 400              |                     |     | 300          | 300 |                           | ✓                | ✓                                    | ✓      | ✓       | ✓  |
|  | from 250<br>to 400 | from 250<br>to 600  | 300 | 300          | ✓   |                           |                  |                                      |        | ✓       | from 1200 ( 850 + 350) to 2000 (1000 + 1000) x from 1775 to 2150**   |
|  | from 250<br>to 400 | from 250<br>to 600  | 300 | 300          | ✓   |                           |                  |                                      |        | ✓       | from 1700 ( 850 + 850) to 2000 (1000 + 1000) x from 1775 to 2150   |
|  | from 250<br>to 620 | from 250<br>to 400  | 325 | 300          | ✓   |                           |                  |                                      |        | ✓       | from 1250 ( 900 + 350) to 2540 (1270 + 1270) x from 1775 to 2670**   |
|  | from 250<br>to 620 | from 250<br>to 400  | 325 | 300          | ✓   |                           |                  |                                      |        | ✓       | from 1800 ( 900 + 900) to 2540 (1270 + 1270) x from 1775 to 2670   |
|  | from 250<br>to 564 | from 250<br>to 443  | 300 | 300          |     | ✓                         | ✓                | ✓                                    | ✓      | ✓       | from 1200 ( 850 + 350) to 2252 (1126 + 1126) x from 1775 to 2275**<br>from 1962 ( 996 + 966) to 2540 (1270 + 1270) x from 2050 to 2500 |
|  | from 250<br>to 564 | from 250<br>to 443  | 300 | 300          |     | ✓                         | ✓                | ✓                                    | ✓      | ✓       | from 1700 ( 850 + 850) to 2252 (1126 + 1126) x from 1775 to 2275<br>from 1962 ( 996 + 966) to 2540 (1270 + 1270) x from 2050 to 2500   |
|  | from 250<br>to 400 | from 630<br>to 1400 | 250 | 300          | ✓   |                           |                  |                                      |        | ✓       | from 1100 ( 750 + 350) to 1800 ( 900 + 900) x from 1775 to 2000<br>from 1539 ( 772 + 767) to 2061 (1028 + 1033) x from 1803 to 2197    |
|  | from 250<br>to 515 | from 500<br>to 1460 | 320 | 300          | ✓   |                           |                  |                                      |        | ✓       | from 1240 ( 890 + 350) to 2315 (1155 + 1160) x from 1775 to 2620<br>from 1975 ( 989 + 986) to 2540 (1268 + 1272) x from 2361 to 2670   |

### NOTE

(\*) Windows only possible for the minimum size of 0,25m<sup>2</sup>, and only on one-leaved doors or the active leaf of two-leaved doors.

(\*\*) FM inactive leaf minimum without window with RC/STD =350mm. FM inactive leaf minimum without window but with RC2=370mm.

# Specific optional accessories

PROGET Fire doors



PROGET fire doors

## FRAME EXTENSIONS FOR PROGET DOORS

### IM 1

Frame extension to be mounted in addition to the Proget frame to serve as embracing frame made of "Sendzimir" processed hot-galvanized sheet metal and painted the same color as the doorframe with epoxy-polyester powders. Profile on three sides, upper corners with 45 degree joint, fixing with screws and plugs in groove (screws and plugs not included).

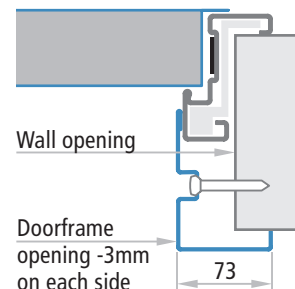
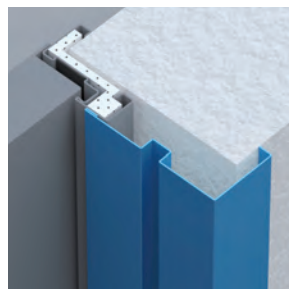

### IM 3

Frame extension to be mounted in addition to the Proget frame to serve as embracing frame, especially for EI<sub>2</sub>90, EI<sub>2</sub>120 with installation for expansion screws fixing. Made of "Sendzimir" processed hot-galvanized sheet metal and painted the same color as the doorframe with epoxy-polyester powders. Profile on three sides, upper corners with 45 degree joint, fixing with screws and plugs (screws and plugs not included).

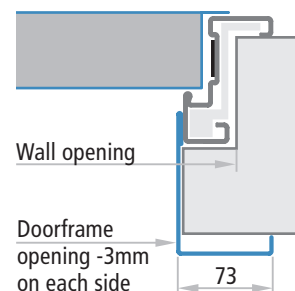
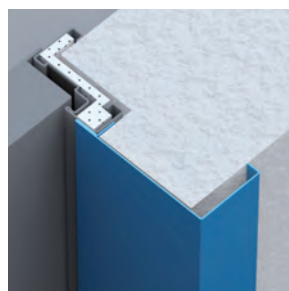

### IM 4

Frame extension to be screwed to the Proget doorframe acting as a wall cladding. Made of "Sendzimir" processed hot-galvanized sheet metal painted the same color as the doorframe with epoxy-polyester powders. Profile on three sides, upper corners with 90 degree joint. Complete with fastener screws. To mount the frame extension, pre-drilled holes are available on the frame. Combine with sealing to conceal the screw heads.

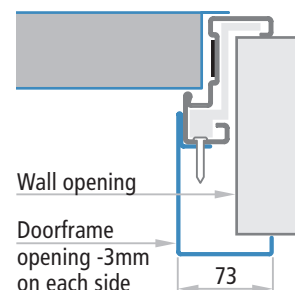
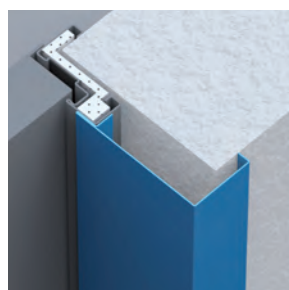

### IM 5

Telescopic frame extension to be screwed to the Proget doorframe acting as a wall cladding for expansion screw fixing. Consists of two overlapping profiles with a 25mm adjustable range. Made of "Sendzimir" processed hot-galvanized sheet metal painted the same color as the doorframe with epoxy-polyester powders. Profile on three sides, upper corners with 90 degree joint. Complete with fastener screws. To mount the frame extension, pre-drilled holes are available on the frame. Combine with sealing to conceal the screw heads.

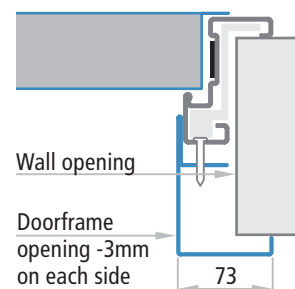
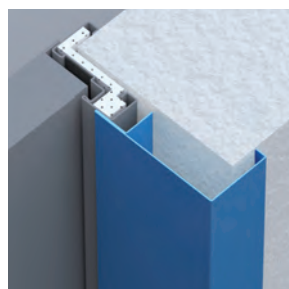

## FRAME ON FOUR SIDES

Upon request one-leaved Proget doors may be supplied with frames on four sides and leaves with or without lower rebate. These type of doors are used mainly for technical rooms or shafts.

The frame on four sides is not available for the following applications: doors installed onto escape routes, two-leaved doors, doors with environmental characteristics, application on lightweight constructions, in combination with frame extensions.

### ATTENTION

With the frame on four sides, the center of the handle will be 15 mm higher than the standard position. For more details, see the page "Door cross section - Measurements".

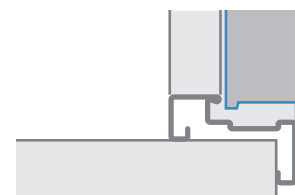

Leaf with lower rebate

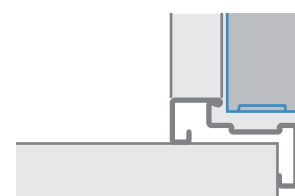

Leaf without lower rebate

# Specific optional accessories

## PROGET Fire doors



### THREE-POINT LOCKING MECHANISM

Mandatory for one-leaved EI<sub>2</sub>120 doors and upon request for a more reliable closure of one- and two-leaved EI<sub>2</sub>60 and two-leaved EI<sub>2</sub>90 doors. In combination with double M1 handle and cylinder. The lock is also available for anti-panic and emergency push versions. Thus the three-point locking mechanism can be combined with emergency handles or with EXUS, TWIST, SLASH type BM panic bars in conformity with CE marking.

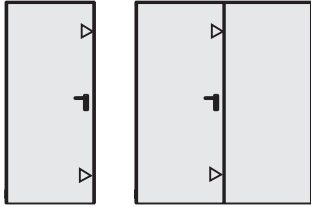

▷ Additional closure points

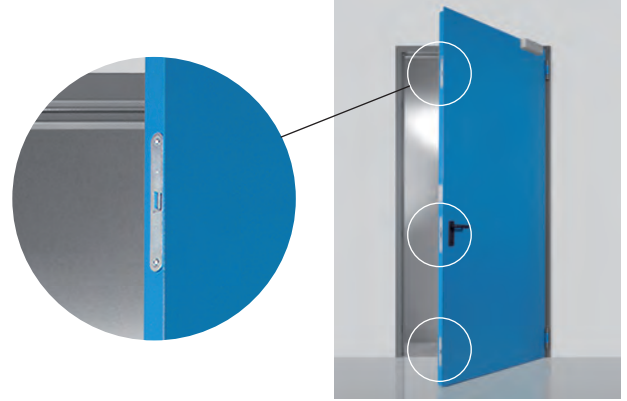

#### NOTE

Three point locking mechanism can be combined with M1, M1C, M1X, M1Xs, M11, M11X, M11Xs handles only.

### STEEL FLOOR CATCH

Floor-mounted steel floor catch for two-leaved Proget doors. Made of pierced and successively galvanized steel. Includes rebate stop for the inactive leaf, the strike box for insertion of the rod, Nr. 3 screws and Nr. 3 plugs. To be used in place of the plastic floor catch for doors that usually remain open and where carts and heavy equipment pass on a regular basis.

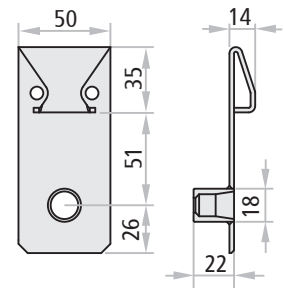

Lower PROGET steel floor catch

### RETREATING FLOOR CATCH „N626“

To be applied in combination with two-leaved PROGET doors, which are usually to be kept open, in substitution of the standard floor catch. The N626's advantage is the embedding of the floor catch into the floor which is activated only by the closing of the inactive leaf. Thus when the doors are open protrusions are avoided guaranteeing nevertheless a correct closing.



#### NOTE

For the passing of the cable of the command function the installation into the floor of a wrinkled cable sleeve is necessary. The installation of the N626 requires trained personnel.

# Specific optional accessories

PROGET Fire doors



PROGET  
fire doors

## REBATE SEALING

CR sealing (for EI<sub>2</sub> doors) and sealing (for REI doors) in black extruded profile to cut and to be pressed into the dedicated groove in the perimetral frame and on the central joint of two-leaved doors.

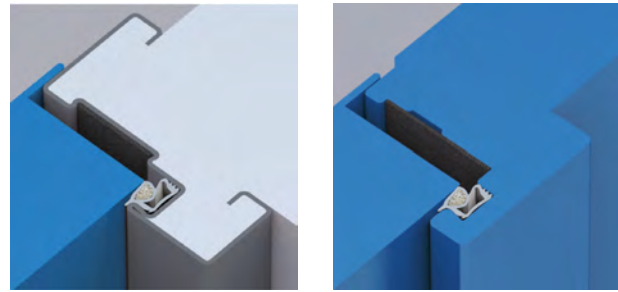

## THRESHOLD

Fixed threshold in anodized aluminium supplied with relative rebate sealing. To be installed for single and double leaved doors onto the floor with screws and plugs (not supplied).

### NOTE

For the installation it is necessary to adapt the threshold to the frame of the door and to drill a hole for its fixing. Further it is necessary to finish up the threshold with silicone.

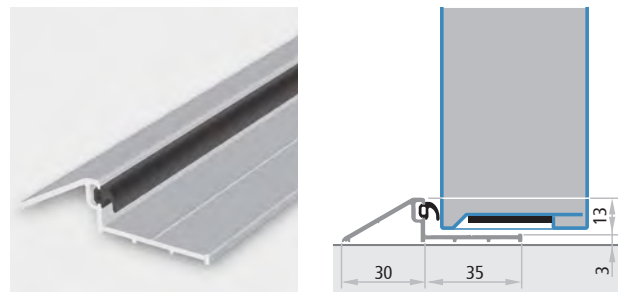

### INTERNAL PEDESTRIAN DOORS

Classification report NO. IFT 16-000122-PR03  
Test report NO. IFT 12-001195-PR01



Pedestrian interior doors are not yet subject to marking as the relevant standard EN 14351-2 has not yet entered into force. The performances contained in the standard can however be a reference for classifying the door for indoor, such as:

- air permeability according to EN 1026:2001
- thermal transmittance according to EN ISO 10077-1:2018 e EN ISO 10077-2:2018

PROGET fire doors are also classified as Sa or S200 for smoke control according to EN 1634-3 (test method) and 13501-2 (classification).

The price list lists the Combos which add these additional performances to the door.

### ATTENTION

For the dimensional limits according to the certificates and homologations of the fire rated doors and regarding the minimum borders please refer to the specific pages of this brochure.

The values for the thermal transmittance  $W/m^2K$  shown in the table on the next page are given by the calculation according to the norm EN ISO 10077-1 done on samples of the dimensions 1,23x2,18 for areas  $\leq 3,6m^2$  and on samples of the dimensions 2,00x2,18 for areas  $> 3,6m^2$ .

All performance values indicated in the table are valid only in presence of the following accessories or enhancements:

- standard frame to be installed with wall anchors and mortar or with screws and plugs
- embracing frame prepared for the installation onto lightweight constructions
- isolation of the frame with the filling of cement or plasterboard
- installation of rubber seals along the entire perimeter of the door frame including the central rebate for double leaved doors
- presence of the automatic door sweep depending upon selected solution.

In case of windows with dimensions larger than those tested (300x400mm), up to a maximum size of 400x600mm the differing performance value for the thermal transmittance needs to be asked, the performance value for acoustic isolation remains unchanged.

For the acoustic isolation performance values, in case of asymmetric double leaved doors ( $L1 \neq L2$ ), select the minor  $R_w$  value of the two (example 1: leaf without windows and  $H=2150$ ,  $L1=1000$ ,  $L2=500$  select 32 dB; example 2: leaf without windows and  $H=2150$ ,  $L1=1200$ ,  $L2=1000$  select 35 dB).



### SMOKE CONTROL ACCORDING TO EN 1634-3

This is the ability of one element to reduce or eliminate the passage of smoke from one side of the door to the other. Two levels of smoke performance are defined.

Smoke control Sa: when the maximum dispersion value measured at room temperature and at a pressure of 25 Pascal is not greater than  $3 m^3/h$  per metre of the gap between the door frame and the door frame excluding loss through the floor threshold.

Smoke control S200: when the maximum dispersion value, measured at room temperature and 200 C and up to a pressure of 50 Pascal, is not greater than  $20 m^3/h$  for a single door or  $30 m^3/h$  for a two-door door.

The smoke tightness is verified with a specific technical test in accordance with UNI EN 1634-3, while the classification is provided by UNI EN 13501-2 according to the following criteria:

Sa considers only the seal at room temperature

S200 considers the seal at room temperature and at 200 C

**Evidence of Performance**  
Smoke leakage and self-closing of construction products and building elements

**Classification Report**  
No.: 16-000122-PR03  
(KB-C05-01-en-03)

**NINZ s.p.a.**  
Client  
Corso Trento 2/A  
38061 ALA  
(Italy)

Prepared by IFT  
Notified body

**ift Rosenheim GmbH**  
Theodor-Cieli-Strasse 7-9  
D-83026 Rosenheim

Notified body No. 0757

Product name  
PROGET MULTI single and double leave  
PROGET REI 60 single and double leave  
PROGET REI 120 single and double leave  
PROGET EI; 60 single and double leave  
PROGET EI; 90 double leave  
PROGET EI; 120 single leave  
  
(nach den Angaben des Auftraggebers)

Classification  
Classification of smoke control and self-closing according to EN 13501-2:2007+A1:2009 / EN 13501-2:2016

Issue No.: 1

**ift**  
**ROSENHEIM**

Standards  
EN 13501-2:2007+A1:2009  
EN 13501-2:2016  
EN 1283-1:2012  
EN 1634-3:2014  
EN 1634-3:2004/AC:2006  
EN 1191:2012  
EN 16034:2014

Instructions for use  
This classification report for smoke control and durability of self-closing devices defines the classification assigned to the building element according to its product name in conformity with the annexes set out in EN 13501-2. This classification document does not represent IFT approval or certification of the product.

Validity  
The data and results given herein solely to the tested and accepted specimen.

Notes on publication  
The IFT Guidance Sheet "Conditions and Guidance for the Use of IFT Test Documents" applies.

Contents  
The classification report consists of 13 pages and may only be used or reproduced in its entirety.

- 1 Introduction
- 2 Details of classified product
- 3 Test reports/classified application reports and test results in support of the classification
- 4 Classification and field of application
- 5 Limitations

**Smoke control doors and shutters**

**Classification**  
S<sub>a</sub> / S<sub>200</sub>  
C5

ift Rosenheim  
01.03.2019

*Gerhard Wackerbauer*  
Dr. Gerhard Wackerbauer, Dipl. Phys.  
Head of Testing Department  
Smoke Control & Mechanical durability

*Christine Schmaaz*  
Christine Schmaaz, Dipl.-Ing. (FH)  
Operating Product Officer  
Building Components

ift Rosenheim GmbH | Rosenheim | Tel: +49 89 21 281 0 | Fax: +49 89 21 281 301 | Pflanzl and Kellermannstr. | EN 1090:2-17:2012 | TÜV SÜD | EN 10204 C7:2012 | Zertifizierungsstelle - EN 10604: 10000

# Additional performances

PROGET Fire doors



## INTERNAL PEDESTRIAN DOORS

Classification report NO. IFT 16-000122-PR03

Test report NO. IFT 12-001195-PR01



| Type                                | FM L x H                                  | Class                          | std angular frame | installation with screw or expansions screws | embracing frame | Combo Thermo/GS - Combo Thermo/GSV<br>Combo dB Sa/GS - Combo dB Sa/GSV<br>version with rebate sealing CR and automatic door sweep<br><br>Combo S200/GS - Combo S200/GSV<br>version with rebate sealing CR and automatic door sweep and three-point locking mechanism |  |   |  | Combo Thermo - Combo Sa<br>version with<br>rebate sealing CR |  |  |  |
|-------------------------------------|---|--------------------------------|-------------------|--|-----------------|--|--|---|--|--|--|--|--|
|                                     |   |                                |                   |  |                 | smoke control according to UNI EN 1634-3   | air permeability according to UNI EN 1026:2001 | thermal transmittance according to UNI EN 10077-1:2018<br>UNI EN 10077-2:2018 | acoustic performance according to UNI EN ISO 140-3 | smoke control according to UNI EN 1634-3                     | air permeability according to UNI EN 1026:2001 | thermal transmittance according to UNI EN 10077-1:2018 |  |
|                                     | ≤ 3,6 m²                                  | REI 60-EI <sub>2</sub> 60      | ✓                 |  |                 | Sa   | S200 classe 2                                  | 1,4 W/m²K   |  | Sa   |  | 1,3 W/m²K  |  |
|                                     | ≤ 3,6 m²                                  | REI 60-EI <sub>2</sub> 60      |                   | ✓  |                 | Sa   | S200 classe 2                                  | 1,3 W/m²K   |  | Sa   |  | 1,3 W/m²K  |  |
|                                     | ≤ 3,6 m²                                  | REI 60-EI <sub>2</sub> 60      |                   |  | ✓               | Sa   | S200 classe 2                                  | 1,5 W/m²K   |  | Sa   |  | 1,5 W/m²K  |  |
|                                     | ≤ 3,6 m²                                  | REI 120-EI <sub>2</sub> 90/120 | ✓                 |  |                 | Sa   | S200 classe 2                                  | 1,4 W/m²K   |  | Sa   |  | 1,4 W/m²K  |  |
|                                     | ≤ 3,6 m²                                  | REI 120-EI <sub>2</sub> 90/120 |                   | ✓  |                 | Sa   | S200 classe 2                                  | 1,4 W/m²K   |  | Sa   |  | 1,3 W/m²K  |  |
|                                     | ≤ 3,6 m²                                  | REI 120-EI <sub>2</sub> 90/120 |                   |  | ✓               | Sa   | S200 classe 2                                  | 1,5 W/m²K   |  | Sa   |  | 1,5 W/m²K  |  |
|                                     | 800 - 1100 x 2000 - 2250                  | REI 120-EI <sub>2</sub> 90/120 | ✓                 | ✓  | ✓               |  |  |   | Rw = 36 dB   |  |  |  |  |
|                                     | 1101 - 1340 x 2000 - 2250                 | REI 120-EI <sub>2</sub> 90/120 | ✓                 | ✓  | ✓               |  |  |   | Rw = 35 dB   |  |  |  |  |
| 800 - 1340 x 2251 - 2670            | REI 120-EI <sub>2</sub> 90/120            | ✓                              | ✓                 | ✓  |                 |  |  | Rw = 34 dB  |  |  |  |  |  |
|                                     | ≤ 3,6 m²                                  | REI 60-EI <sub>2</sub> 60      | ✓                 |  |                 | Sa   | S200 classe 2                                  | 1,9 W/m²K   |  | Sa   |  | 1,9 W/m²K  |  |
|                                     | ≤ 3,6 m²                                  | REI 60-EI <sub>2</sub> 60      |                   | ✓  |                 | Sa   | S200 classe 2                                  | 1,9 W/m²K   |  | Sa   |  | 1,9 W/m²K  |  |
|                                     | ≤ 3,6 m²                                  | REI 60-EI <sub>2</sub> 60      |                   |  | ✓               | Sa   | S200 classe 2                                  | 2,1 W/m²K   |  | Sa   |  | 2,0 W/m²K  |  |
|                                     | ≤ 3,6 m²                                  | REI 120-EI <sub>2</sub> 90/120 | ✓                 |  |                 | Sa   | S200 classe 2                                  | 1,9 W/m²K   |  | Sa   |  | 1,9 W/m²K  |  |
|                                     | ≤ 3,6 m²                                  | REI 120-EI <sub>2</sub> 90/120 |                   | ✓  |                 | Sa   | S200 classe 2                                  | 1,8 W/m²K   |  | Sa   |  | 1,8 W/m²K  |  |
|                                     | ≤ 3,6 m²                                  | REI 120-EI <sub>2</sub> 90/120 |                   |  | ✓               | Sa   | S200 classe 2                                  | 2,0 W/m²K   |  | Sa   |  | 2,0 W/m²K  |  |
|                                     | 800 - 1100 x 2000 - 2250                  | REI 120-EI <sub>2</sub> 90/120 | ✓                 | ✓  | ✓               |  |  |   | Rw = 36 dB   |  |  |  |  |
|                                     | 1101 - 1340 x 2000 - 2250                 | REI 120-EI <sub>2</sub> 90/120 | ✓                 | ✓  | ✓               |  |  |   | Rw = 35 dB   |  |  |  |  |
| 800 - 1340 x 2251 - 2670            | REI 120-EI <sub>2</sub> 90/120            | ✓                              | ✓                 | ✓  |                 |  |  | Rw = 34 dB  |  |  |  |  |  |
|                                     | ≤ 3,6 m²                                  | REI 60-EI <sub>2</sub> 60      | ✓                 |  |                 | Sa   | S200 classe 3                                  | 1,8 W/m²K   |  | Sa   |  | 1,8 W/m²K  |  |
|                                     | > 3,6 m²                                  | REI 60-EI <sub>2</sub> 60      | ✓                 |  |                 | Sa   | S200 classe 3                                  | 1,5 W/m²K   |  | Sa   |  | 1,4 W/m²K  |  |
|                                     | ≤ 3,6 m²                                  | REI 60-EI <sub>2</sub> 60      |                   | ✓  |                 | Sa   | S200 classe 3                                  | 1,8 W/m²K   |  | Sa   |  | 1,7 W/m²K  |  |
|                                     | > 3,6 m²                                  | REI 60-EI <sub>2</sub> 60      |                   | ✓  |                 | Sa   | S200 classe 3                                  | 1,4 W/m²K   |  | Sa   |  | 1,4 W/m²K  |  |
|                                     | ≤ 3,6 m²                                  | REI 60-EI <sub>2</sub> 60      |                   |  | ✓               | Sa   | S200 classe 3                                  | 1,9 W/m²K   |  | Sa   |  | 1,9 W/m²K  |  |
|                                     | > 3,6 m²                                  | REI 60-EI <sub>2</sub> 60      |                   |  | ✓               | Sa   | S200 classe 3                                  | 1,6 W/m²K   |  | Sa   |  | 1,5 W/m²K  |  |
|                                     | ≤ 3,6 m²                                  | REI 120-EI <sub>2</sub> 90/120 | ✓                 |  |                 | Sa   | S200 classe 3                                  | 1,8 W/m²K   |  | Sa   |  | 1,8 W/m²K  |  |
|                                     | > 3,6 m²                                  | REI 120-EI <sub>2</sub> 90/120 | ✓                 |  |                 | Sa   | S200 classe 3                                  | 1,5 W/m²K   |  | Sa   |  | 1,5 W/m²K  |  |
|                                     | ≤ 3,6 m²                                  | REI 120-EI <sub>2</sub> 90/120 |                   | ✓  |                 | Sa   | S200 classe 3                                  | 1,8 W/m²K   |  | Sa   |  | 1,8 W/m²K  |  |
|                                     | > 3,6 m²                                  | REI 120-EI <sub>2</sub> 90/120 |                   | ✓  |                 | Sa   | S200 classe 3                                  | 1,5 W/m²K   |  | Sa   |  | 1,4 W/m²K  |  |
|                                     | ≤ 3,6 m²                                  | REI 120-EI <sub>2</sub> 90/120 |                   |  | ✓               | Sa   | S200 classe 3                                  | 2,0 W/m²K   |  | Sa   |  | 1,9 W/m²K  |  |
|                                     | > 3,6 m²                                  | REI 120-EI <sub>2</sub> 90/120 |                   |  | ✓               | Sa   | S200 classe 3                                  | 1,6 W/m²K   |  | Sa   |  | 1,6 W/m²K  |  |
|                                     | FM min 1000 (L1/L2 max 799) x 2000 - 2670 | REI 120-EI <sub>2</sub> 90/120 | ✓                 | ✓  | ✓               |  |  |   |  | Rw = 32 dB   |  |  |  |
|                                     | (L1 o L2) 800 - 1100 x 2000 - 2250        | REI 120-EI <sub>2</sub> 90/120 | ✓                 | ✓  | ✓               |  |  |   |  | Rw = 36 dB   |  |  |  |
| (L1 o L2) 1101 - 1330 x 2000 - 2250 | REI 120-EI <sub>2</sub> 90/120            | ✓                              | ✓                 | ✓  |                 |  |  |   | Rw = 35 dB   |  |  |  |  |
| (L1 o L2) 800 - 1330 x 2251 - 2670  | REI 120-EI <sub>2</sub> 90/120            | ✓                              | ✓                 | ✓  |                 |  |  |   | Rw = 34 dB   |  |  |  |  |
|                                     | ≤ 3,6 m²                                  | REI 60-EI <sub>2</sub> 60      | ✓                 |  |                 | Sa   | S200 classe 3                                  | 2,3 W/m²K   |  | Sa   |  | 2,3 W/m²K  |  |
|                                     | > 3,6 m²                                  | REI 60-EI <sub>2</sub> 60      | ✓                 |  |                 | Sa   | S200 classe 3                                  | 2,1 W/m²K   |  | Sa   |  | 2,1 W/m²K  |  |
|                                     | ≤ 3,6 m²                                  | REI 60-EI <sub>2</sub> 60      |                   | ✓  |                 | Sa   | S200 classe 3                                  | 2,3 W/m²K   |  | Sa   |  | 2,3 W/m²K  |  |
|                                     | > 3,6 m²                                  | REI 60-EI <sub>2</sub> 60      |                   | ✓  |                 | Sa   | S200 classe 3                                  | 2,1 W/m²K   |  | Sa   |  | 2,0 W/m²K  |  |
|                                     | ≤ 3,6 m²                                  | REI 60-EI <sub>2</sub> 60      |                   |  | ✓               | Sa   | S200 classe 3                                  | 2,5 W/m²K   |  | Sa   |  | 2,4 W/m²K  |  |
|                                     | > 3,6 m²                                  | REI 60-EI <sub>2</sub> 60      |                   |  | ✓               | Sa   | S200 classe 3                                  | 2,2 W/m²K   |  | Sa   |  | 2,2 W/m²K  |  |
|                                     | ≤ 3,6 m²                                  | REI 120-EI <sub>2</sub> 90/120 | ✓                 |  |                 | Sa   | S200 classe 3                                  | 2,3 W/m²K   |  | Sa   |  | 2,3 W/m²K  |  |
|                                     | > 3,6 m²                                  | REI 120-EI <sub>2</sub> 90/120 | ✓                 |  |                 | Sa   | S200 classe 3                                  | 2,1 W/m²K   |  | Sa   |  | 2,0 W/m²K  |  |
|                                     | ≤ 3,6 m²                                  | REI 120-EI <sub>2</sub> 90/120 |                   | ✓  |                 | Sa   | S200 classe 3                                  | 2,3 W/m²K   |  | Sa   |  | 2,2 W/m²K  |  |
|                                     | > 3,6 m²                                  | REI 120-EI <sub>2</sub> 90/120 |                   | ✓  |                 | Sa   | S200 classe 3                                  | 2,0 W/m²K   |  | Sa   |  | 2,0 W/m²K  |  |
|                                     | ≤ 3,6 m²                                  | REI 120-EI <sub>2</sub> 90/120 |                   |  | ✓               | Sa   | S200 classe 3                                  | 2,4 W/m²K   |  | Sa   |  | 2,4 W/m²K  |  |
|                                     | > 3,6 m²                                  | REI 120-EI <sub>2</sub> 90/120 |                   |  | ✓               | Sa   | S200 classe 3                                  | 2,2 W/m²K   |  | Sa   |  | 2,1 W/m²K  |  |
|                                     | FM min 1000 (L1/L2 max 799) x 2000 - 2670 | REI 120-EI <sub>2</sub> 90/120 | ✓                 | ✓  | ✓               |  |  |   |  | Rw = 32 dB   |  |  |  |
|                                     | (L1 o L2) 800 - 1100 x 2000 - 2250        | REI 120-EI <sub>2</sub> 90/120 | ✓                 | ✓  | ✓               |  |  |   |  | Rw = 36 dB   |  |  |  |
| (L1 o L2) 1101 - 1330 x 2000 - 2250 | REI 120-EI <sub>2</sub> 90/120            | ✓                              | ✓                 | ✓  |                 |  |  |   | Rw = 35 dB   |  |  |  |  |
| (L1 o L2) 1101 - 1330 x 2000 - 2250 | REI 120-EI <sub>2</sub> 90/120            | ✓                              | ✓                 | ✓  |                 |  |  |   | Rw = 34 dB   |  |  |  |  |

PROGET  
fire doors

# Additional performances

PROGET Fire doors



PROGET  
fire doors

## EXTERNAL PEDESTRIAN DOORS



Certificate CE 1404 - CPR - 3737 (for EI<sub>2</sub>60)

Certificate CE 1404 - CPR - 3912 (for EI<sub>2</sub>90)

Certificate CE 1404 - CPR - 3846 (for EI<sub>2</sub>120)

EN 16034:2014 - EN 14351-1:2006+A2:2016

According to standards EN 16034 and EN 14351-1, an external door is defined as a door that separates the internal climate from the external environment of a building. For this application, doors must be CE marked in accordance with EN 16034:2014 and EN 14351-1:2006+A2:2016. Furthermore, if the door is installed along an escape route and equipped with a panic or emergency exit device, it is also subject to the assessment and verification of constancy of performance under "System 1". This requires the manufacturer to hold a Certificate of Constancy of Performance issued by a Notified Organization.

Proget fire doors for external use must be ordered with the specific CE Combo Est options available in the Proget fire door price list, selected based on the essential requirements indicated in the tables on the following pages, and considering those that are mandatory according to the applicable national regulations. This ensures that each door is provided with the required CE marking and the documentation specified by the current legislation.

## ATTENTION

For dimensional limits, minimum edge requirements and production options, please refer to the specific pages of this catalogue. The thermal transmittance values (W/m<sup>2</sup>K) shown in the tables on the following pages are calculated in accordance with EN ISO 10077-1, applied to samples measuring 1.23 x 2.18 m for areas ≤ 3.6 m<sup>2</sup> and to samples measuring 2.00 x 2.18 m for areas > 3.6 m<sup>2</sup>. All performance values listed in the table are valid only if the door is installed with the following accessories and measures:

- presence of a bottom rebate threshold in case of installation along an escape route and just in case of Proget with frame on 4 sides, the floor on the push side must be raised to fully level the gap between the floor and the bottom threshold
- frame insulation by filling with polyurethane foam or cement-based mortar
- application of sealing gaskets along the entire perimeter of the frame and on the central mullion in double-leaf doors
- sealing of the frame's perimeter edge (on the push side) with neutral silicone
- for doors with vision panels: installation of external fire-resistant glazing sized 300x400 mm

In case of windows up to a maximum size of max 400x600mm the differing performance value for the thermal transmittance needs to be asked, all other performance values remain unchanged.

For the acoustic isolation performance values, in case of asymmetric double leaved doors (L1≠L2), select the minor Rw value of the two.

example 1: leaf without windows and H=2150, L1=1000, L2= 500 select 30 dB;

example 2: leaf without windows and H=2150, L1=1200, L2=1000 select 32 dB.

## NOTES

For information regarding outdoor installation, please refer to the "Warnings" section on the last page of this catalogue.



ZAVOD ZA  
GRADBENIŠTVO  
SLOVENIJE  
SI OVERIHM  
NATIONAL BUILDING  
AND CIVIL ENGINEERING  
INSTITUTE  
Družnecova ulica 12  
1000 Ljubljana  
Slovenija  
info@zag.si  
www.zag.si  
Notified certification body  
NB 1404

Certificate  
of constancy of performance

1404 – CPR – 3737

In compliance with Regulation (EU) No 305/2011 of the European Parliament and of the Council of 9 March 2011 (the Construction Products Regulation or CPR), this certificate applies to the construction product

Single and double leaf fire door PROGET EI 60  
(doors that fall within the scope of standard EN 14351-1:2006+A2:2016)

placed on the market under the name or trade mark of

**NINZ S.p.A.**,  
Corso Trento 2, 38061 Ala (TN), Italy

and produced in the manufacturing plants

**NINZ S.p.A.**,  
Corso Trento 2, 38061 Ala (TN), Italy

and  
**NINZ S.p.A.**,  
Via Negrelli 17, 39100 Bolzano, Italy.

This certificate attests that all provisions concerning the assessment and verification of constancy of performance described in Annex ZA of the standards

EN 16034:2014 and EN 14351-1:2006+A2:2016

under system 1 for the performance set out in this certificate are applied and that the factory production control conducted by the manufacturer is assessed to ensure the

constancy of performance of the construction product.

This certificate was first issued on 4. 6. 2024 and will remain valid until 4. 6. 2029 as long as neither the harmonised standards, the construction products, the AVCP method nor the manufacturing conditions in the plant are modified significantly, unless suspended or withdrawn by the notified product certification body.

Detailed information about the scope of the product is given in the annex to this certificate.

Ljubljana, 4. 6. 2024

Authorised signatory of the Certification body:  
mag. Egon Miloš, univ.dipl.inž.grad.

ZAG-011-308-2v1

This certificate has a total of 2 pages

Certificate No. 1404 – CPR – 3737, issue 1

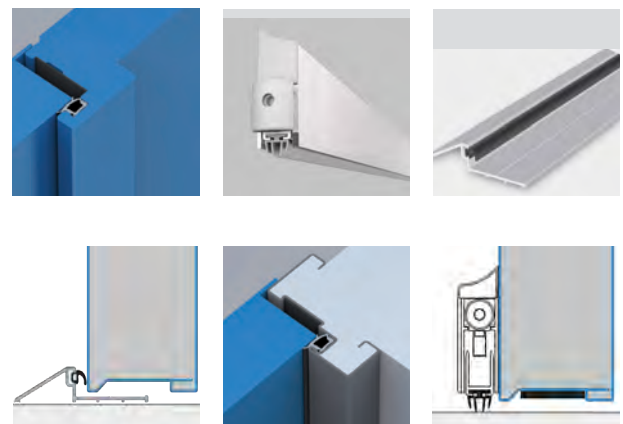



# Additional performances

PROGET Fire doors



PROGET  
fire doors

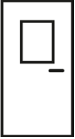

| PROGET Fire Door EI <sub>2</sub> 60   |  | Angular frame        | Tunnel frame | Combo with CR rebate gasket and door closer for C5 version |                         | Combo with CR rebate gasket, drop-down seal and door closer for C5 version |                         |        |
|---|--|----------------------|--------------|--|-------------------------|--|-------------------------|--------|
|   |  |                      |              | CE   | CE C5                   | CE Sa/SF   | CE Sa/SF C5             |        |
| Certificate CE:<br>1404 - CPR -3737  |  |                      |              |  |                         |  |                         |        |
| Without windows<br>                  | <b>EN 16034:2014</b>   |                      |              |  |                         |  |                         |        |
|   | Fire resistance  | ✓                    | ✓            | EI, 60   | EI, 60                  | EI, 60   | EI, 60                  |        |
|   | Smoke control  | ✓                    | ✓            | N.P.D.   | N.P.D.                  | Sa   | Sa                      |        |
|   | Ability to release / lock  | ✓                    | ✓            | N.P.D.   | N.P.D.                  | N.P.D.   | N.P.D.                  |        |
|   | Self-closing   | ✓                    | ✓            | C  | C                       | C  | C                       |        |
|   | Durability of release mechanism  | ✓                    | ✓            | N.P.D.   | N.P.D.                  | N.P.D.   | N.P.D.                  |        |
|   | Durability of self-closing   |                      |              |  |                         |  |                         |        |
|   | - against degradation  | ✓                    | ✓            | 0  | 5                       | 0  | 5                       |        |
|   | - against corrosion  | ✓                    | ✓            | N.P.D.   | N.P.D.                  | N.P.D.   | N.P.D.                  |        |
|   | <b>EN 14351-1:2006+A2:2016</b>   |                      |              |  |                         |  |                         |        |
|   | Air permeability   | ✓                    | ✓            | N.P.D.   | N.P.D.                  | 2  | 2                       |        |
|   | Water tightness  | ✓                    | ✓            | N.P.D.   | N.P.D.                  | 1A   | 1A                      |        |
|   | Wind load resistance   |                      |              |  |                         |  |                         |        |
|   | - door with FM ≤ 1140x2150   | ✓                    | ✓            | N.P.D.   | N.P.D.                  | C1   | C1                      |        |
|   | - door with FM > 1140x2150   | ✓                    | ✓            | N.P.D.   | N.P.D.                  | N.P.D.   | N.P.D.                  |        |
|   | Impact resistance  | ✓                    | ✓            | N.P.D.   | N.P.D.                  | N.P.D.   | N.P.D.                  |        |
|   | Load-bearing capacity of safety devices  | ✓                    | ✓            | Exceeds  | Exceeds                 | Exceeds  | Exceeds                 |        |
|   | Acoustic performance   | ✓                    | ✓            | N.P.D.   | N.P.D.                  | N.P.D.   | N.P.D.                  |        |
|   | Thermal transmittance  | ✓                    |              | 1,30 W/m <sup>2</sup> K                                    | 1,30 W/m <sup>2</sup> K | 1,40 W/m <sup>2</sup> K  | 1,40 W/m <sup>2</sup> K |        |
|   | Thermal transmittance  |                      | ✓            | 1,50 W/m <sup>2</sup> K                                    | 1,50 W/m <sup>2</sup> K | 1,50 W/m <sup>2</sup> K  | 1,50 W/m <sup>2</sup> K |        |
|   | Ability to release / open  | ✓                    | ✓            | N.P.D.   | N.P.D.                  | N.P.D.   | N.P.D.                  |        |
|   | With windows<br>300x400<br> | <b>EN 16034:2014</b> |              |  |                         |  |                         |        |
|   |  | Fire resistance      | ✓            | ✓  | EI, 60                  | EI, 60   | EI, 60                  | EI, 60 |
| Smoke control   |  | ✓                    | ✓            | N.P.D.   | N.P.D.                  | Sa   | Sa                      |        |
| Ability to release / lock   |  | ✓                    | ✓            | N.P.D.   | N.P.D.                  | N.P.D.   | N.P.D.                  |        |
| Self-closing  |  | ✓                    | ✓            | C  | C                       | C  | C                       |        |
| Durability of release mechanism   |  | ✓                    | ✓            | N.P.D.   | N.P.D.                  | N.P.D.   | N.P.D.                  |        |
| Durability of self-closing  |  |                      |              |  |                         |  |                         |        |
| - against degradation   |  | ✓                    | ✓            | 0  | 5                       | 0  | 5                       |        |
| - against corrosion   |  | ✓                    | ✓            | N.P.D.   | N.P.D.                  | N.P.D.   | N.P.D.                  |        |
| <b>EN 14351-1:2006+A2:2016</b>  |  |                      |              |  |                         |  |                         |        |
| Air permeability  |  | ✓                    | ✓            | N.P.D.   | N.P.D.                  | 2  | 2                       |        |
| Water tightness   |  | ✓                    | ✓            | N.P.D.   | N.P.D.                  | 1A   | 1A                      |        |
| Wind load resistance  |  |                      |              |  |                         |  |                         |        |
| - door with FM ≤ 1140x2150  |  | ✓                    | ✓            | N.P.D.   | N.P.D.                  | C1   | C1                      |        |
| - door with FM > 1140x2150  |  | ✓                    | ✓            | N.P.D.   | N.P.D.                  | N.P.D.   | N.P.D.                  |        |
| Impact resistance   |  | ✓                    | ✓            | N.P.D.   | N.P.D.                  | N.P.D.   | N.P.D.                  |        |
| Load-bearing capacity of safety devices   |  | ✓                    | ✓            | Exceeds  | Exceeds                 | Exceeds  | Exceeds                 |        |
| Acoustic performance  |  | ✓                    | ✓            | N.P.D.   | N.P.D.                  | N.P.D.   | N.P.D.                  |        |
| Thermal transmittance   |  | ✓                    |              | 1,90 W/m <sup>2</sup> K                                    | 1,90 W/m <sup>2</sup> K | 1,90 W/m <sup>2</sup> K  | 1,90 W/m <sup>2</sup> K |        |
| Thermal transmittance   |  |                      | ✓            | 2,00 W/m <sup>2</sup> K                                    | 2,00 W/m <sup>2</sup> K | 2,10 W/m <sup>2</sup> K  | 2,10 W/m <sup>2</sup> K |        |
| Ability to release / open   |  | ✓                    | ✓            | N.P.D.   | N.P.D.                  | N.P.D.   | N.P.D.                  |        |

# Additional performances

PROGET Fire doors



PROGET  
fire doors



| <b>PROGET Fire Door EI<sub>2</sub> 60</b><br><br>Certificate CE: <br>1404 - CPR -3737 |   | Angular Frame | Tunnel frame | Combo with CR rebate gasket, drop-down seal and door closer for C5 version |                           |
|--|---|---------------|--------------|--|---------------------------|
|  |   |               |              | CE S200/GS<br>CE S200/GSV  | CE S200/GS<br>CE S200/GSV |
| <b>Without windows</b><br><br>  | <b>EN 16034:2014</b>                    |               |              |  |                           |
|  | Fire resistance                         | ✓             | ✓            | EI <sub>2</sub> 60   | EI <sub>2</sub> 60        |
|  | Smoke control                           | ✓             | ✓            | S200   | S200                      |
|  | Ability to release / lock               | ✓             | ✓            | N.P.D.   | N.P.D.                    |
|  | Self-closing                            | ✓             | ✓            | C  | C                         |
|  | Durability of release mechanism         | ✓             | ✓            | N.P.D.   | N.P.D.                    |
|  | Durability of self-closing              |               |              |  |                           |
|  | - against degradation                   | ✓             | ✓            | 0  | 5                         |
|  | - against corrosion                     | ✓             | ✓            | N.P.D.   | N.P.D.                    |
|  | <b>EN 14351-1:2006+A2:2016</b>          |               |              |  |                           |
|  | Air permeability                        | ✓             | ✓            | 2  | 2                         |
|  | Water tightness                         | ✓             | ✓            | N.P.D.   | N.P.D.                    |
|  | Wind load resistance                    | ✓             | ✓            | N.P.D.   | N.P.D.                    |
|  | Impact resistance                       | ✓             | ✓            | N.P.D.   | N.P.D.                    |
|  | Load-bearing capacity of safety devices | ✓             | ✓            | Passa  | Passa                     |
|  | Acoustic performance                    | ✓             | ✓            | 32 dB  | 32 dB                     |
|  | Thermal transmittance                   | ✓             |              | 1,40 W/m <sup>2</sup> K  | 1,40 W/m <sup>2</sup> K   |
|  | Thermal transmittance                   |               | ✓            | 1,50 W/m <sup>2</sup> K  | 1,50 W/m <sup>2</sup> K   |
| Ability to release / open  | ✓                                       | ✓             | N.P.D.       | N.P.D.   |                           |
| <b>With windows<br/>300x400</b><br><br>   | <b>EN 16034:2014</b>                    |               |              |  |                           |
|  | Fire resistance                         | ✓             | ✓            | EI <sub>2</sub> 60   | EI <sub>2</sub> 60        |
|  | Smoke control                           | ✓             | ✓            | S200   | S200                      |
|  | Ability to release / lock               | ✓             | ✓            | N.P.D.   | N.P.D.                    |
|  | Self-closing                            | ✓             | ✓            | C  | C                         |
|  | Durability of release mechanism         | ✓             | ✓            | N.P.D.   | N.P.D.                    |
|  | Durability of self-closing              |               |              |  |                           |
|  | - against degradation                   | ✓             | ✓            | 0  | 5                         |
|  | - against corrosion                     | ✓             | ✓            | N.P.D.   | N.P.D.                    |
|  | <b>EN 14351-1:2006+A2:2016</b>          |               |              |  |                           |
|  | Air permeability                        | ✓             | ✓            | 2  | 2                         |
|  | Water tightness                         | ✓             | ✓            | N.P.D.   | N.P.D.                    |
|  | Wind load resistance                    | ✓             | ✓            | N.P.D.   | N.P.D.                    |
|  | Impact resistance                       | ✓             | ✓            | N.P.D.   | N.P.D.                    |
|  | Load-bearing capacity of safety devices | ✓             | ✓            | Passa  | Passa                     |
|  | Acoustic performance                    | ✓             | ✓            | 32 dB  | 32 dB                     |
|  | Thermal transmittance                   | ✓             |              | 1,90 W/m <sup>2</sup> K  | 1,90 W/m <sup>2</sup> K   |
|  | Thermal transmittance                   |               | ✓            | 2,10 W/m <sup>2</sup> K  | 2,10 W/m <sup>2</sup> K   |
| Ability to release / open  | ✓                                       | ✓             | N.P.D.       | N.P.D.   |                           |

# Additional performances

PROGET Fire doors



PROGET  
fire doors

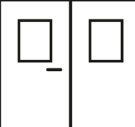
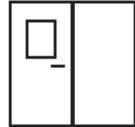

| PROGET Fire Door EI <sub>2</sub> 60<br><br>Certificate CE:<br>1404 - CPR -3737                                       |   | Angular Frame | Tunnel frame            | Combo with CR rebate gasket and door closer for C5 version |                         | Combo with CR rebate gasket, drop-down seal and door closer for C5 version |                         |
|---|---|---------------|-------------------------|--|-------------------------|--|-------------------------|
|   |   |               |                         | CE   | CE C5                   | CE Sa/SF   | CE Sa/SF C5             |
| Without windows<br>  | <b>EN 16034:2014</b>                          |               |                         |  |                         |  |                         |
|   | Fire resistance                               | ✓             | ✓                       | EI, 60   | EI, 60                  | EI, 60   | EI, 60                  |
|   | Smoke control                                 | ✓             | ✓                       | N.P.D.   | N.P.D.                  | S200   | S200                    |
|   | Ability to release / lock                     | ✓             | ✓                       | N.P.D.   | N.P.D.                  | N.P.D.   | N.P.D.                  |
|   | Self-closing                                  | ✓             | ✓                       | C  | C                       | C  | C                       |
|   | Durability of self-closing                    |               |                         |  |                         |  |                         |
|   | - against degradation                         | ✓             | ✓                       | 0  | 5                       | 0  | 5                       |
|   | - against corrosion                           | ✓             | ✓                       | N.P.D.   | N.P.D.                  | N.P.D.   | N.P.D.                  |
|   | <b>EN 14351-1:2006+A2:2016</b>                |               |                         |  |                         |  |                         |
|   | Air permeability                              | ✓             | ✓                       | N.P.D.   | N.P.D.                  | 3  | 3                       |
|   | Water tightness                               | ✓             | ✓                       | N.P.D.   | N.P.D.                  | 2A - 4B  | 2A - 4B                 |
|   | Wind load resistance                          | ✓             | ✓                       |  |                         |  |                         |
|   | - door with FM ≤ 2300x2150                    | ✓             | ✓                       | N.P.D.   | N.P.D.                  | C1   | C1                      |
|   | - door with FM > 2300x2150                    | ✓             | ✓                       | N.P.D.   | N.P.D.                  | N.P.D.   | N.P.D.                  |
|   | Load-bearing capacity of safety devices       | ✓             | ✓                       | Exceeds  | Exceeds                 | Exceeds  | Exceeds                 |
|   | Acoustic performance                          | ✓             | ✓                       | 32 dB  | 32 dB                   | 32 dB  | 32 dB                   |
|   | Thermal transmittance FM ≤ 3,6 m <sup>2</sup> | ✓             |                         | 1,80 W/m <sup>2</sup> K                                    | 1,80 W/m <sup>2</sup> K | 1,80 W/m <sup>2</sup> K  | 1,80 W/m <sup>2</sup> K |
|   | Thermal transmittance FM > 3,6 m <sup>2</sup> | ✓             |                         | 1,40 W/m <sup>2</sup> K                                    | 1,40 W/m <sup>2</sup> K | 1,50 W/m <sup>2</sup> K  | 1,50 W/m <sup>2</sup> K |
|   | Thermal transmittance FM ≤ 3,6 m <sup>2</sup> |               | ✓                       | 1,90 W/m <sup>2</sup> K                                    | 1,90 W/m <sup>2</sup> K | 1,90 W/m <sup>2</sup> K  | 1,90 W/m <sup>2</sup> K |
| Thermal transmittance FM > 3,6 m <sup>2</sup>   |   | ✓             | 1,50 W/m <sup>2</sup> K | 1,50 W/m <sup>2</sup> K                                    | 1,60 W/m <sup>2</sup> K | 1,60 W/m <sup>2</sup> K  |                         |
| With windows<br>300x400<br><br> | <b>EN 16034:2014</b>                          |               |                         |  |                         |  |                         |
|   | Fire resistance                               | ✓             | ✓                       | EI, 60   | EI, 60                  | EI, 60   | EI, 60                  |
|   | Smoke control                                 | ✓             | ✓                       | N.P.D.   | N.P.D.                  | Sa   | Sa                      |
|   | Ability to release / lock                     | ✓             | ✓                       | N.P.D.   | N.P.D.                  | N.P.D.   | N.P.D.                  |
|   | Self-closing                                  | ✓             | ✓                       | C  | C                       | C  | C                       |
|   | Durability of self-closing                    |               |                         |  |                         |  |                         |
|   | - against degradation                         | ✓             | ✓                       | 0  | 5                       | 0  | 5                       |
|   | - against corrosion                           | ✓             | ✓                       | N.P.D.   | N.P.D.                  | N.P.D.   | N.P.D.                  |
|   | <b>EN 14351-1:2006+A2:2016</b>                |               |                         |  |                         |  |                         |
|   | Air permeability                              | ✓             | ✓                       | N.P.D.   | N.P.D.                  | 3  | 3                       |
|   | Water tightness                               | ✓             | ✓                       | N.P.D.   | N.P.D.                  | 2A - 4B  | 2A - 4B                 |
|   | Wind load resistance                          | ✓             | ✓                       |  |                         |  |                         |
|   | - door with FM ≤ 2300x2150                    | ✓             | ✓                       | N.P.D.   | N.P.D.                  | C1   | C1                      |
|   | - door with FM > 2300x2150                    | ✓             | ✓                       | N.P.D.   | N.P.D.                  | N.P.D.   | N.P.D.                  |
|   | Load-bearing capacity of safety devices       | ✓             | ✓                       | Exceeds  | Exceeds                 | Exceeds  | Exceeds                 |
|   | Acoustic performance                          | ✓             | ✓                       | 32 dB  | 32 dB                   | 32 dB  | 32 dB                   |
|   | Thermal transmittance FM ≤ 3,6 m <sup>2</sup> | ✓             |                         | 2,30 W/m <sup>2</sup> K                                    | 2,30 W/m <sup>2</sup> K | 2,30 W/m <sup>2</sup> K  | 2,30 W/m <sup>2</sup> K |
|   | Thermal transmittance FM > 3,6 m <sup>2</sup> | ✓             |                         | 2,10 W/m <sup>2</sup> K                                    | 2,10 W/m <sup>2</sup> K | 2,10 W/m <sup>2</sup> K  | 2,10 W/m <sup>2</sup> K |
|   | Thermal transmittance FM ≤ 3,6 m <sup>2</sup> |               | ✓                       | 2,40 W/m <sup>2</sup> K                                    | 2,40 W/m <sup>2</sup> K | 2,50 W/m <sup>2</sup> K  | 2,50 W/m <sup>2</sup> K |
| Thermal transmittance FM > 3,6 m <sup>2</sup>   |   | ✓             | 2,20 W/m <sup>2</sup> K | 2,20 W/m <sup>2</sup> K                                    | 2,20 W/m <sup>2</sup> K | 2,20 W/m <sup>2</sup> K  |                         |

# Additional performances

PROGET Fire doors

**NINZ**  
FIREDOORS

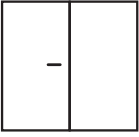
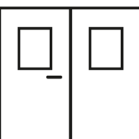
PROGET  
fire doors

| <b>PROGET Fire Door EI<sub>2</sub> 60</b><br><br>Certificate CE:<br>1404 - CPR -3737                                    |   | Angular frame | Tunnel frame            | Combo with CR rebate gasket, drop-down seal and door closer for C5 version |                           |
|--|---|---------------|-------------------------|--|---------------------------|
|  |   |               |                         | CE S200/GS<br>CE S200/GSV  | CE S200/GS<br>CE S200/GSV |
| <b>Without window</b><br>   | <b>EN 16034:2014</b>                          |               |                         |  |                           |
|  | Fire resistance                               | ✓             | ✓                       | EI <sub>2</sub> 60   | EI <sub>2</sub> 60        |
|  | Smoke control                                 | ✓             | ✓                       | S200   | S200                      |
|  | Ability to release / lock                     | ✓             | ✓                       | N.P.D.   | N.P.D.                    |
|  | Self-closing                                  | ✓             | ✓                       | C  | C                         |
|  | Durability of self-closing                    |               |                         | N.P.D.   | N.P.D.                    |
|  | - against degradation                         | ✓             | ✓                       | 0  | 5                         |
|  | - against corrosion                           | ✓             | ✓                       | N.P.D.   | N.P.D.                    |
|  | <b>EN 14351-1:2006+A2:2016</b>                |               |                         |  |                           |
|  | Air permeability                              | ✓             | ✓                       | 3  | 3                         |
|  | Water tightness                               | ✓             | ✓                       | N.P.D.   | N.P.D.                    |
|  | Wind load resistance                          | ✓             | ✓                       | N.P.D.   | N.P.D.                    |
|  | Load-bearing capacity of safety devices       | ✓             | ✓                       | Exceeds  | Exceeds                   |
|  | Acoustic performance                          | ✓             | ✓                       | 32 dB  | 32 dB                     |
|  | Thermal transmittance FM ≤ 3,6 m <sup>2</sup> | ✓             |                         | 1,80 W/m <sup>2</sup> K  | 1,80 W/m <sup>2</sup> K   |
|  | Thermal transmittance FM > 3,6 m <sup>2</sup> | ✓             |                         | 1,50 W/m <sup>2</sup> K  | 1,50 W/m <sup>2</sup> K   |
| Thermal transmittance FM ≤ 3,6 m <sup>2</sup>  |   | ✓             | 1,90 W/m <sup>2</sup> K | 1,90 W/m <sup>2</sup> K  |                           |
| Thermal transmittance FM > 3,6 m <sup>2</sup>  |   | ✓             | 1,60 W/m <sup>2</sup> K | 1,60 W/m <sup>2</sup> K  |                           |
| <b>With window 300x400</b><br><br> | <b>EN 16034:2014</b>                          |               |                         |  |                           |
|  | Fire resistance                               | ✓             | ✓                       | EI <sub>2</sub> 60   | EI <sub>2</sub> 60        |
|  | Smoke control                                 | ✓             | ✓                       | S200   | S200                      |
|  | Ability to release / lock                     | ✓             | ✓                       | N.P.D.   | N.P.D.                    |
|  | Self-closing                                  | ✓             | ✓                       | C  | C                         |
|  | Durability of self-closing                    |               |                         |  |                           |
|  | - against degradation                         | ✓             | ✓                       | 0  | 5                         |
|  | - against corrosion                           | ✓             | ✓                       | N.P.D.   | N.P.D.                    |
|  | <b>EN 14351-1:2006+A2:2016</b>                |               |                         |  |                           |
|  | Air permeability                              | ✓             | ✓                       | 3  | 3                         |
|  | Water tightness                               | ✓             | ✓                       | N.P.D.   | N.P.D.                    |
|  | Wind load resistance                          | ✓             | ✓                       | N.P.D.   | N.P.D.                    |
|  | Load-bearing capacity of safety devices       | ✓             | ✓                       | Exceeds  | Exceeds                   |
|  | Acoustic performance                          | ✓             | ✓                       | 32 dB  | 32 dB                     |
|  | Thermal transmittance FM ≤ 3,6 m <sup>2</sup> | ✓             |                         | 2,30 W/m <sup>2</sup> K  | 2,30 W/m <sup>2</sup> K   |
|  | Thermal transmittance FM > 3,6 m <sup>2</sup> | ✓             |                         | 2,10 W/m <sup>2</sup> K  | 2,10 W/m <sup>2</sup> K   |
| Thermal transmittance FM ≤ 3,6 m <sup>2</sup>  |   | ✓             | 2,50 W/m <sup>2</sup> K | 2,50 W/m <sup>2</sup> K  |                           |
| Thermal transmittance FM > 3,6 m <sup>2</sup>  |   | ✓             | 2,20 W/m <sup>2</sup> K | 2,20 W/m <sup>2</sup> K  |                           |

# Additional performances

PROGET Fire doors

**NINZ**<sup>®</sup>  
FIRE DOORS

PROGET  
fire doors

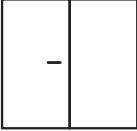
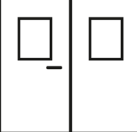
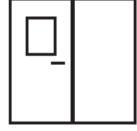

| PROGET Fire Door EI <sub>2</sub> 90<br>Certificate CE <br>1404 - CPR -3912   |   | Angular Frame | Tunnel frame            | Combo with CR rebate gasket and door closer for C5 version |                         | Combo with CR rebate gasket, drop-down seal and door closer for C5 version |                         |
|---|---|---------------|-------------------------|--|-------------------------|--|-------------------------|
|   |   |               |                         | CE   | CE C5                   | CE Sa/SF   | CE Sa/SF C5             |
| Without windows<br>  | <b>EN 16034:2014</b>                          |               |                         |  |                         |  |                         |
|   | Fire resistance                               | ✓             | ✓                       | EI <sub>2</sub> 90   | EI <sub>2</sub> 90      | EI <sub>2</sub> 90   | EI <sub>2</sub> 90      |
|   | Smoke control                                 | ✓             | ✓                       | N.P.D.   | N.P.D.                  | S200   | S200                    |
|   | Ability to release / lock                     | ✓             | ✓                       | N.P.D.   | N.P.D.                  | N.P.D.   | N.P.D.                  |
|   | Self-closing                                  | ✓             | ✓                       | C  | C                       | C  | C                       |
|   | Durability of self-closing                    |               |                         |  |                         |  |                         |
|   | - against degradation                         | ✓             | ✓                       | 0  | 0                       | 0  | 0                       |
|   | - against corrosion                           | ✓             | ✓                       | N.P.D.   | N.P.D.                  | N.P.D.   | N.P.D.                  |
|   | <b>EN 14351-1:2006+A2:2016</b>                |               |                         |  |                         |  |                         |
|   | Air permeability                              | ✓             | ✓                       | N.P.D.   | N.P.D.                  | 3  | 3                       |
|   | Water tightness                               | ✓             | ✓                       | N.P.D.   | N.P.D.                  | 2A - 4B  | 2A - 4B                 |
|   | Wind load resistance                          | ✓             | ✓                       |  |                         |  |                         |
|   | - door with FM ≤ 2300x2150                    | ✓             | ✓                       | N.P.D.   | N.P.D.                  | C1   | C1                      |
|   | - door with FM > 2300x2150                    | ✓             | ✓                       | N.P.D.   | N.P.D.                  | N.P.D.   | N.P.D.                  |
|   | Load-bearing capacity of safety devices       | ✓             | ✓                       | Exceeds  | Exceeds                 | Exceeds  | Exceeds                 |
|   | Acoustic performance                          | ✓             | ✓                       | N.P.D.   | N.P.D.                  | N.P.D.   | N.P.D.                  |
|   | Thermal transmittance FM ≤ 3,6 m <sup>2</sup> | ✓             |                         | 1,80 W/m <sup>2</sup> K                                    | 1,80 W/m <sup>2</sup> K | 1,80 W/m <sup>2</sup> K  | 1,80 W/m <sup>2</sup> K |
|   | Thermal transmittance FM > 3,6 m <sup>2</sup> | ✓             |                         | 1,50 W/m <sup>2</sup> K                                    | 1,50 W/m <sup>2</sup> K | 1,50 W/m <sup>2</sup> K  | 1,50 W/m <sup>2</sup> K |
|   | Thermal transmittance FM ≤ 3,6 m <sup>2</sup> |               | ✓                       | 1,90 W/m <sup>2</sup> K                                    | 1,90 W/m <sup>2</sup> K | 2,00 W/m <sup>2</sup> K  | 2,00 W/m <sup>2</sup> K |
| Thermal transmittance FM > 3,6 m <sup>2</sup>   |   | ✓             | 1,50 W/m <sup>2</sup> K | 1,50 W/m <sup>2</sup> K                                    | 1,60 W/m <sup>2</sup> K | 1,60 W/m <sup>2</sup> K  |                         |
| With windows<br>300x400<br><br> | <b>EN 16034:2014</b>                          |               |                         |  |                         |  |                         |
|   | Fire resistance                               | ✓             | ✓                       | EI <sub>2</sub> 90   | EI <sub>2</sub> 90      | EI <sub>2</sub> 90   | EI <sub>2</sub> 90      |
|   | Smoke control                                 | ✓             | ✓                       | N.P.D.   | N.P.D.                  | Sa   | Sa                      |
|   | Ability to release / lock                     | ✓             | ✓                       | N.P.D.   | N.P.D.                  | N.P.D.   | N.P.D.                  |
|   | Self-closing                                  | ✓             | ✓                       | C  | C                       | C  | C                       |
|   | Durability of self-closing                    |               |                         |  |                         |  |                         |
|   | - against degradation                         | ✓             | ✓                       | 0  | 0                       | 0  | 0                       |
|   | - against corrosion                           | ✓             | ✓                       | N.P.D.   | N.P.D.                  | N.P.D.   | N.P.D.                  |
|   | <b>EN 14351-1:2006+A2:2016</b>                |               |                         |  |                         |  |                         |
|   | Air permeability                              | ✓             | ✓                       | N.P.D.   | N.P.D.                  | 3  | 3                       |
|   | Water tightness                               | ✓             | ✓                       | N.P.D.   | N.P.D.                  | 2A - 4B  | 2A - 4B                 |
|   | Wind load resistance                          | ✓             | ✓                       |  |                         |  |                         |
|   | - door with FM ≤ 2300x2150                    | ✓             | ✓                       | N.P.D.   | N.P.D.                  | C1   | C1                      |
|   | - door with FM > 2300x2150                    | ✓             | ✓                       | N.P.D.   | N.P.D.                  | N.P.D.   | N.P.D.                  |
|   | Load-bearing capacity of safety devices       | ✓             | ✓                       | Exceeds  | Exceeds                 | Exceeds  | Exceeds                 |
|   | Acoustic performance                          | ✓             | ✓                       | N.P.D.   | N.P.D.                  | N.P.D.   | N.P.D.                  |
|   | Thermal transmittance FM ≤ 3,6 m <sup>2</sup> | ✓             |                         | 2,30 W/m <sup>2</sup> K                                    | 2,30 W/m <sup>2</sup> K | 2,30 W/m <sup>2</sup> K  | 2,30 W/m <sup>2</sup> K |
|   | Thermal transmittance FM > 3,6 m <sup>2</sup> | ✓             |                         | 2,00 W/m <sup>2</sup> K                                    | 2,00 W/m <sup>2</sup> K | 2,10 W/m <sup>2</sup> K  | 2,10 W/m <sup>2</sup> K |
|   | Thermal transmittance FM ≤ 3,6 m <sup>2</sup> |               | ✓                       | 2,40 W/m <sup>2</sup> K                                    | 2,40 W/m <sup>2</sup> K | 2,40 W/m <sup>2</sup> K  | 2,40 W/m <sup>2</sup> K |
| Thermal transmittance FM > 3,6 m <sup>2</sup>   |   | ✓             | 2,10 W/m <sup>2</sup> K | 2,10 W/m <sup>2</sup> K                                    | 2,20 W/m <sup>2</sup> K | 2,20 W/m <sup>2</sup> K  |                         |

# Additional performances

PROGET Fire doors

**NINZ**  
FIREDOORS

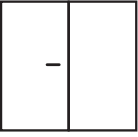
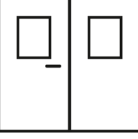
PROGET  
fire doors



| <b>PROGET Fire Door EI<sub>2</sub> 90</b><br><br>Certificate CE:<br>1404 - CPR -3912                                    |   | Angular frame | Tunnel frame            | Combo with CR rebate gasket, drop-down seal and door closer for C5 version |                           |
|--|---|---------------|-------------------------|--|---------------------------|
|  |   |               |                         | CE S200/GS<br>CE S200/GSV  | CE S200/GS<br>CE S200/GSV |
| <b>Without window</b><br>   | <b>EN 16034:2014</b>                          |               |                         |  |                           |
|  | Fire resistance                               | ✓             | ✓                       | EI, 90   | EI, 90                    |
|  | Smoke control                                 | ✓             | ✓                       | S200   | S200                      |
|  | Ability to release / lock                     | ✓             | ✓                       | N.P.D.   | N.P.D.                    |
|  | Self-closing                                  | ✓             | ✓                       | C  | C                         |
|  | Durability of self-closing                    |               |                         | N.P.D.   | N.P.D.                    |
|  | - against degradation                         | ✓             | ✓                       | 0  | 0                         |
|  | - against corrosion                           | ✓             | ✓                       | N.P.D.   | N.P.D.                    |
|  | <b>EN 14351-1:2006+A2:2016</b>                |               |                         |  |                           |
|  | Air permeability                              | ✓             | ✓                       | 3  | 3                         |
|  | Water tightness                               | ✓             | ✓                       | N.P.D.   | N.P.D.                    |
|  | Wind load resistance                          | ✓             | ✓                       | N.P.D.   | N.P.D.                    |
|  | Load-bearing capacity of safety devices       | ✓             | ✓                       | Exceeds  | Exceeds                   |
|  | Acoustic performance                          | ✓             | ✓                       | 32-36 dB (*)   | 32-36 dB (*)              |
|  | Thermal transmittance FM ≤ 3,6 m <sup>2</sup> | ✓             |                         | 1,80 W/m <sup>2</sup> K  | 1,80 W/m <sup>2</sup> K   |
|  | Thermal transmittance FM > 3,6 m <sup>2</sup> | ✓             |                         | 1,50 W/m <sup>2</sup> K  | 1,50 W/m <sup>2</sup> K   |
| Thermal transmittance FM ≤ 3,6 m <sup>2</sup>  |   | ✓             | 2,00 W/m <sup>2</sup> K | 2,00 W/m <sup>2</sup> K  |                           |
| Thermal transmittance FM > 3,6 m <sup>2</sup>  |   | ✓             | 1,60 W/m <sup>2</sup> K | 1,60 W/m <sup>2</sup> K  |                           |
| <b>With window 300x400</b><br><br> | <b>EN 16034:2014</b>                          |               |                         |  |                           |
|  | Fire resistance                               | ✓             | ✓                       | EI, 90   | EI, 90                    |
|  | Smoke control                                 | ✓             | ✓                       | S200   | S200                      |
|  | Ability to release / lock                     | ✓             | ✓                       | N.P.D.   | N.P.D.                    |
|  | Self-closing                                  | ✓             | ✓                       | C  | C                         |
|  | Durability of self-closing                    |               |                         |  |                           |
|  | - against degradation                         | ✓             | ✓                       | 0  | 0                         |
|  | - against corrosion                           | ✓             | ✓                       | N.P.D.   | N.P.D.                    |
|  | <b>EN 14351-1:2006+A2:2016</b>                |               |                         |  |                           |
|  | Air permeability                              | ✓             | ✓                       | 3  | 3                         |
|  | Water tightness                               | ✓             | ✓                       | N.P.D.   | N.P.D.                    |
|  | Wind load resistance                          | ✓             | ✓                       | N.P.D.   | N.P.D.                    |
|  | Load-bearing capacity of safety devices       | ✓             | ✓                       | Exceeds  | Exceeds                   |
|  | Acoustic performance                          | ✓             | ✓                       | 32-36 dB (*)   | 32-36 dB (*)              |
|  | Thermal transmittance FM ≤ 3,6 m <sup>2</sup> | ✓             |                         | 2,30 W/m <sup>2</sup> K  | 2,30 W/m <sup>2</sup> K   |
|  | Thermal transmittance FM > 3,6 m <sup>2</sup> | ✓             |                         | 2,10 W/m <sup>2</sup> K  | 2,10 W/m <sup>2</sup> K   |
| Thermal transmittance FM ≤ 3,6 m <sup>2</sup>  |   | ✓             | 2,40 W/m <sup>2</sup> K | 2,40 W/m <sup>2</sup> K  |                           |
| Thermal transmittance FM > 3,6 m <sup>2</sup>  |   | ✓             | 2,20 W/m <sup>2</sup> K | 2,20 W/m <sup>2</sup> K  |                           |

# Additional performances

PROGET Fire doors

**NINZ**<sup>®</sup>  
FIRE DOORS

PROGET  
fire doors

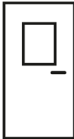

| PROGET Fire Door EI <sub>2</sub> 120<br><br>Certificate CE: <br>1404 - CPR -3846 |   | Angular frame | Tunnel frame | Combo with CR rebate gasket and door closer for C5 version |                         | Combo with CR rebate gasket, drop-down seal and door closer for C5 version |                         |
|---|---|---------------|--------------|--|-------------------------|--|-------------------------|
|   |   |               |              | CE   | CE C5                   | CE Sa/SF   | CE Sa/SF C5             |
| Without windows<br>  | <b>EN 16034:2014</b>                    |               |              |  |                         |  |                         |
|   | Fire resistance                         | ✓             | ✓            | EI, 120  | EI, 120                 | EI, 120  | EI, 120                 |
|   | Smoke control                           | ✓             | ✓            | N.P.D.   | N.P.D.                  | Sa   | Sa                      |
|   | Ability to release / lock               | ✓             | ✓            | N.P.D.   | N.P.D.                  | N.P.D.   | N.P.D.                  |
|   | Self-closing                            | ✓             | ✓            | C  | C                       | C  | C                       |
|   | Durability of release mechanism         | ✓             | ✓            | N.P.D.   | N.P.D.                  | N.P.D.   | N.P.D.                  |
|   | Durability of self-closing              |               |              |  |                         |  |                         |
|   | - against degradation                   | ✓             | ✓            | 0  | 0                       | 0  | 0                       |
|   | - against corrosion                     | ✓             | ✓            | N.P.D.   | N.P.D.                  | N.P.D.   | N.P.D.                  |
|   | <b>EN 14351-1:2006+A2:2016</b>          |               |              |  |                         |  |                         |
|   | Air permeability                        | ✓             | ✓            | N.P.D.   | N.P.D.                  | 2  | 2                       |
|   | Water tightness                         | ✓             | ✓            | N.P.D.   | N.P.D.                  | 1A   | 1A                      |
|   | Wind load resistance                    |               |              |  |                         |  |                         |
|   | - door with FM ≤ 1140x2150              | ✓             | ✓            | N.P.D.   | N.P.D.                  | C1   | C1                      |
|   | - door with FM > 1140x2150              | ✓             | ✓            | N.P.D.   | N.P.D.                  | C1   | C1                      |
|   | Impact resistance                       | ✓             | ✓            | N.P.D.   | N.P.D.                  | N.P.D.   | N.P.D.                  |
|   | Load-bearing capacity of safety devices | ✓             | ✓            | Exceeds  | Exceeds                 | Exceeds  | Exceeds                 |
|   | Acoustic performance                    | ✓             | ✓            | N.P.D.   | N.P.D.                  | N.P.D.   | N.P.D.                  |
|   | Thermal transmittance                   | ✓             |              | 1,40 W/m <sup>2</sup> K                                    | 1,40 W/m <sup>2</sup> K | 1,40 W/m <sup>2</sup> K  | 1,40 W/m <sup>2</sup> K |
|   | Thermal transmittance                   |               | ✓            | 1,50 W/m <sup>2</sup> K                                    | 1,50 W/m <sup>2</sup> K | 1,50 W/m <sup>2</sup> K  | 1,50 W/m <sup>2</sup> K |
| Ability to release / open   | ✓                                       | ✓             | N.P.D.       | N.P.D.   | N.P.D.                  | N.P.D.   |                         |
| With windows 300x400<br>   | <b>EN 16034:2014</b>                    |               |              |  |                         |  |                         |
|   | Fire resistance                         | ✓             | ✓            | EI, 120  | EI, 120                 | EI, 120  | EI, 120                 |
|   | Smoke control                           | ✓             | ✓            | N.P.D.   | N.P.D.                  | Sa   | Sa                      |
|   | Ability to release / lock               | ✓             | ✓            | N.P.D.   | N.P.D.                  | N.P.D.   | N.P.D.                  |
|   | Self-closing                            | ✓             | ✓            | C  | C                       | C  | C                       |
|   | Durability of release mechanism         | ✓             | ✓            | N.P.D.   | N.P.D.                  | N.P.D.   | N.P.D.                  |
|   | Durability of self-closing              |               |              |  |                         |  |                         |
|   | - against degradation                   | ✓             | ✓            | 0  | 5                       | 0  | 5                       |
|   | - against corrosion                     | ✓             | ✓            | N.P.D.   | N.P.D.                  | N.P.D.   | N.P.D.                  |
|   | <b>EN 14351-1:2006+A2:2016</b>          |               |              |  |                         |  |                         |
|   | Air permeability                        | ✓             | ✓            | N.P.D.   | N.P.D.                  | 2  | 2                       |
|   | Water tightness                         | ✓             | ✓            | N.P.D.   | N.P.D.                  | 1A   | 1A                      |
|   | Wind load resistance                    |               |              |  |                         |  |                         |
|   | - door with FM ≤ 1140x2150              | ✓             | ✓            | N.P.D.   | N.P.D.                  | C1   | C1                      |
|   | - door with FM > 1140x2150              | ✓             | ✓            | N.P.D.   | N.P.D.                  | C1   | C1                      |
|   | Impact resistance                       | ✓             | ✓            | N.P.D.   | N.P.D.                  | N.P.D.   | N.P.D.                  |
|   | Load-bearing capacity of safety devices | ✓             | ✓            | Exceeds  | Exceeds                 | Exceeds  | Exceeds                 |
|   | Acoustic performance                    | ✓             | ✓            | N.P.D.   | N.P.D.                  | N.P.D.   | N.P.D.                  |
|   | Thermal transmittance                   | ✓             |              | 1,90 W/m <sup>2</sup> K                                    | 1,90 W/m <sup>2</sup> K | 1,90 W/m <sup>2</sup> K  | 1,90 W/m <sup>2</sup> K |
|   | Thermal transmittance                   |               | ✓            | 2,00 W/m <sup>2</sup> K                                    | 2,00 W/m <sup>2</sup> K | 2,00 W/m <sup>2</sup> K  | 2,00 W/m <sup>2</sup> K |
| Ability to release / open   | ✓                                       | ✓             | N.P.D.       | N.P.D.   | N.P.D.                  | N.P.D.   |                         |

# Additional performances

PROGET Fire doors

**NINZ**  
FIREDOORS

PROGET  
fire doors

| <b>PROGET Fire Door EI<sub>2</sub> 120</b><br><br>Certificate CE:<br>1404 - CPR -3846  |   | Angular Frame | Tunnel frame | Combo with CR rebate gasket, drop-down seal and door closer for C5 version |                           |
|---|---|---------------|--------------|--|---------------------------|
|   |   |               |              | CE S200/GS<br>CE S200/GSV  | CE S200/GS<br>CE S200/GSV |
| <b>Without windows</b><br><br>   | <b>EN 16034:2014</b>                    |               |              |  |                           |
|   | Fire resistance                         | ✓             | ✓            | EI, 120  | EI, 120                   |
|   | Smoke control                           | ✓             | ✓            | S200   | S200                      |
|   | Ability to release / lock               | ✓             | ✓            | N.P.D.   | N.P.D.                    |
|   | Self-closing                            | ✓             | ✓            | C  | C                         |
|   | Durability of release mechanism         | ✓             | ✓            | N.P.D.   | N.P.D.                    |
|   | Durability of self-closing              |               |              |  |                           |
|   | - against degradation                   | ✓             | ✓            | 0  | 0                         |
|   | - against corrosion                     | ✓             | ✓            | N.P.D.   | N.P.D.                    |
|   | <b>EN 14351-1:2006+A2:2016</b>          |               |              |  |                           |
|   | Air permeability                        | ✓             | ✓            | 2  | 2                         |
|   | Water tightness                         | ✓             | ✓            | N.P.D.   | N.P.D.                    |
|   | Wind load resistance                    | ✓             | ✓            | N.P.D.   | N.P.D.                    |
|   | Impact resistance                       | ✓             | ✓            | N.P.D.   | N.P.D.                    |
|   | Load-bearing capacity of safety devices | ✓             | ✓            | Passa  | Passa                     |
|   | Acoustic performance                    | ✓             | ✓            | 34 - 36 dB(**)   | 34 - 36 dB(**)            |
|   | Thermal transmittance                   | ✓             |              | 1,40 W/m <sup>2</sup> K  | 1,40 W/m <sup>2</sup> K   |
|   | Thermal transmittance                   |               | ✓            | 1,50 W/m <sup>2</sup> K  | 1,50 W/m <sup>2</sup> K   |
| Ability to release / open   | ✓                                       | ✓             | N.P.D.       | N.P.D.   |                           |
| <b>With windows<br/>300x400</b><br><br>  | <b>EN 16034:2014</b>                    |               |              |  |                           |
|   | Fire resistance                         | ✓             | ✓            | EI, 60   | EI, 60                    |
|   | Smoke control                           | ✓             | ✓            | S200   | S200                      |
|   | Ability to release / lock               | ✓             | ✓            | N.P.D.   | N.P.D.                    |
|   | Self-closing                            | ✓             | ✓            | C  | C                         |
|   | Durability of release mechanism         | ✓             | ✓            | N.P.D.   | N.P.D.                    |
|   | Durability of self-closing              |               |              |  |                           |
|   | - against degradation                   | ✓             | ✓            | 0  | 5                         |
|   | - against corrosion                     | ✓             | ✓            | N.P.D.   | N.P.D.                    |
|   | <b>EN 14351-1:2006+A2:2016</b>          |               |              |  |                           |
|   | Air permeability                        | ✓             | ✓            | 2  | 2                         |
|   | Water tightness                         | ✓             | ✓            | N.P.D.   | N.P.D.                    |
|   | Wind load resistance                    | ✓             | ✓            | N.P.D.   | N.P.D.                    |
|   | Impact resistance                       | ✓             | ✓            | N.P.D.   | N.P.D.                    |
|   | Load-bearing capacity of safety devices | ✓             | ✓            | Passa  | Passa                     |
|   | Acoustic performance                    | ✓             | ✓            | 34 - 36 dB(**)   | 34 - 36 dB(**)            |
|   | Thermal transmittance                   | ✓             |              | 1,90 W/m <sup>2</sup> K  | 1,90 W/m <sup>2</sup> K   |
|   | Thermal transmittance                   |               | ✓            | 2,00 W/m <sup>2</sup> K  | 2,00 W/m <sup>2</sup> K   |
| Ability to release / open   | ✓                                       | ✓             | N.P.D.       | N.P.D.   |                           |

# Additional performances

PROGET Fire doors



PROGET  
fire doors

| Essential requirements*  | EN 16034 | EN 14351 |
|--|----------|----------|
| Fire resistance  | YES      | NO       |
| Smoke control  | YES      | NO       |
| Self - closing   | YES      | NO       |
| Durability of performance  | YES      | NO       |
| Thermal insulation   | NO       | YES      |
| Air permeability   | NO       | YES      |
| Water tightness  | NO       | NO       |
| Acoustic performance   | NO       | NO       |
| Wind resistance  | NO       | NO       |
| Load-bearing capacity of safety devices  | NO       | YES      |
| Release/unlocking capability<br>(mandatory for doors installed on escape routes) | NO       | YES      |
| Minimum clear passage height: 2000 mm  | NO       | YES      |

\* Required under binding national provisions

## WARNING

For doors exposed to weather conditions and/or direct sunlight, the customer must take appropriate precautions to prevent long-term deterioration, in particular:

- Canopies or overhangs
- Outdoor paint with UV protection
- Use of light RAL colours to avoid overheating of metal sheets

## NOTE (\*)

The acoustic performance of Proget EI<sub>2</sub>90 CE doors depends on the dimensions of the leaves. Specifically:

| Leaves | Width       | Height      | Acoustic perf. |
|--------|-------------|-------------|----------------|
| L1/L2  | 500 - 799   | 2000 - 2670 | 32 dB          |
| L1/L2  | 800 - 1100  | 2000 - 2250 | 36 dB          |
| L1/L2  | 1101 - 1330 | 2000 - 2250 | 35 dB          |
| L1/L2  | 800 - 1330  | 2251 - 2500 | 35 dB          |
| L1/L2  | 800 - 1330  | 2501 - 2670 | 34 dB          |

For the acoustic isolation performance values, in case of asymmetric double leaved doors (L1≠L2), select the minor Rw value of the two.

## NOTE (\*\*)

The acoustic performance of Proget EI<sub>2</sub>120 CE doors depends on the dimensions of the leaf. Specifically:

| Leaves | Width      | Height      | Acoustic perf. |
|--------|------------|-------------|----------------|
| L1     | 800 - 1100 | 2000 - 2250 | 36 dB          |
| L1     | 800 - 1100 | 2000 - 2250 | 35 dB          |
| L1     | 800 - 1340 | 2251 - 2670 | 35 dB          |
| L1     | 800 - 1340 | 2251 - 2670 | 34 dB          |

# Door cross sections - Measurements

PROGET Fire doors



PROGET  
fire doors

**One-leaved doors - Horizontal cross section**

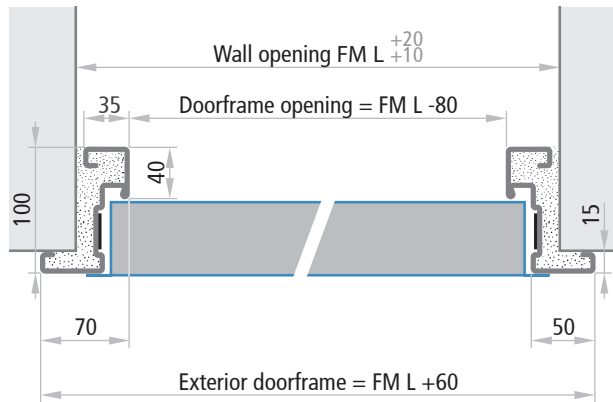

**Doors without lower threshold - Vertical cross section**

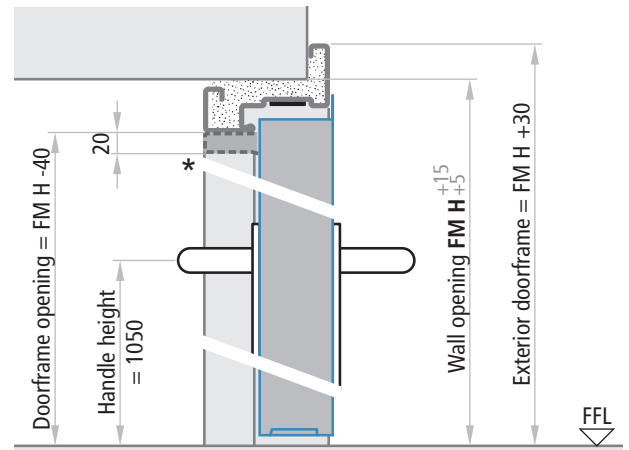

\* RC/STD position in case of additional performances

**Two-leaved doors - Horizontal cross section**

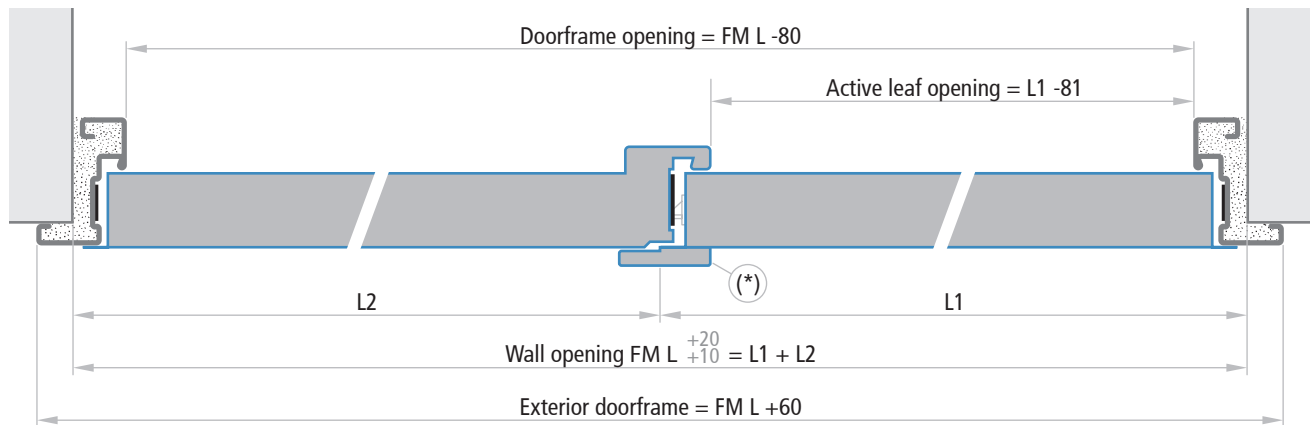

**One-leaved doors with frame on 4 sides and leaf with lower rebate - Vertical cross section**

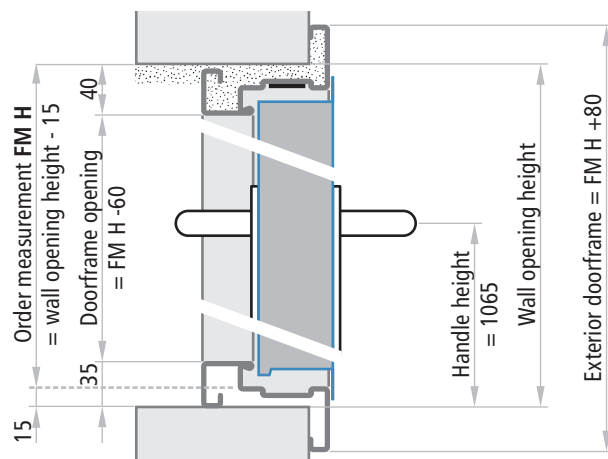

**One-leaved doors with frame on 4 sides and leaf without lower rebate - Vertical cross section**

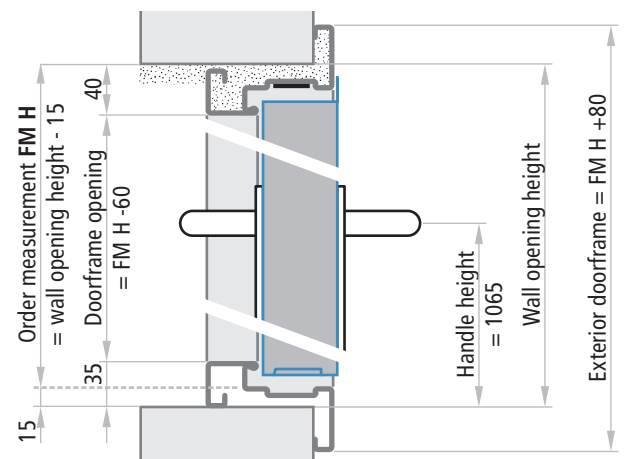

## Leaves thickness

|            |       |
|------------|-------|
| Fire doors | 60 mm |
|------------|-------|

## NOTE

The tolerances  $FM L +20$ ,  $FM H +15$  of the indicated measurements make it easier to fill the gap between the wall and the doorframe with cement mortar.

For dry wall installation, the holes must be precise and greater tolerance ranges should not be employed.

(\*) Proget EI,90 two leaved doors feature an additional isolated central rebate profile, which is applied onto the active leaf.

# Standard installation method

PROGET Fire doors



PROGET  
fire doors

## INSTALLATION WITH ANCHORS FOR MORTAR FIXING

The standard installation method for Proget doors is to use the anchors for mortar fixing. Appropriate cuts will need to be created in the walls (section 80 x 200 mm). The anchors should be bent and blocked inside the wall. For fire sealing purposes and a perfect mechanical fit, the space between the doorframe and the masonry shall always be filled with concrete mortar.



### One-leaved doors

FM L = from 500 to 1035 x FM H = from 1775 to 2200

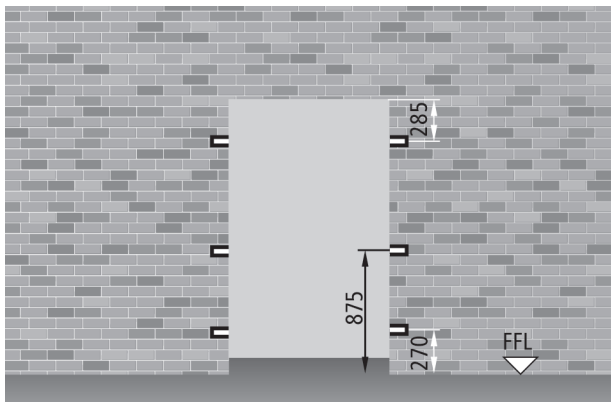

FM L greater than 1035 and/or FM H greater than 2200

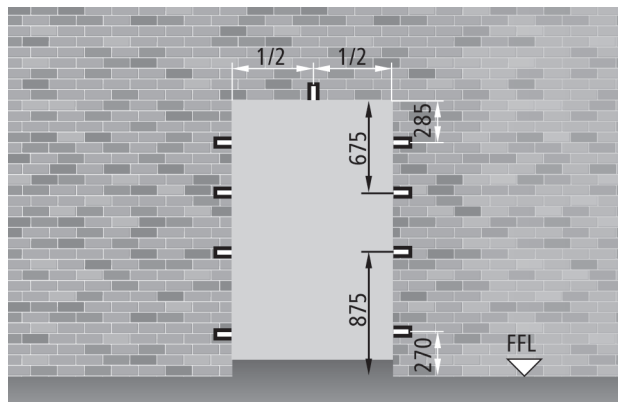

### Two-leaved doors

FM L = from 850 to 2070 x FM H = from 1775 to 2200

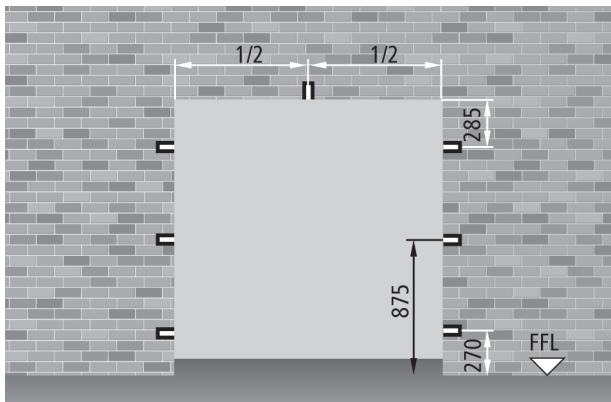

FM L greater than 2070 and/or FM H greater than 2200

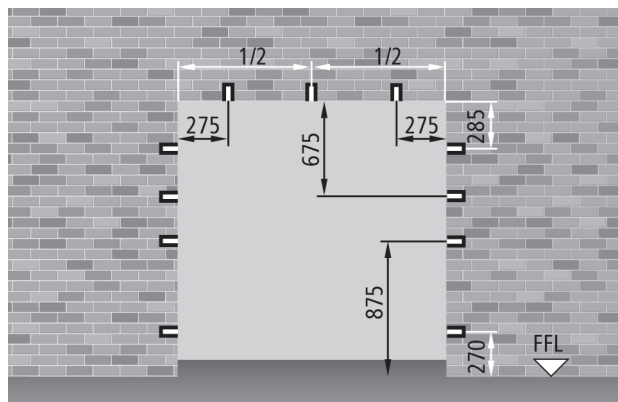

#### NOTE

For proper installation, the cuts for the anchors should be 80 x 200 mm in size.

# Optional installation methods

PROGET Fire doors



PROGET  
fire doors

## DRY WALL INSTALLATION ONTO THE SUBFRAME WITH SCREWS

Installation method certified for one- or two-leaved REI 60 and REI 120 doors, in conformity with UNI 9723 standard, for screw fixing onto metal subframes in the walls.

Subframes need to be ordered separately from the door. Make sure measurements correspond to the door's FM L x FM H measurements.

For the technical characteristics of the subframe, see the specific page of the section "accessories doors".

The supplied doorframe comes factory heat-insulated with special materials and includes corner joints and a lower spacer (except for one-leaved doors with frame on four sides) to be added on site.

The subframe method allows a "dry wall" installation of the doors, making an installation onto finished masonry possible.

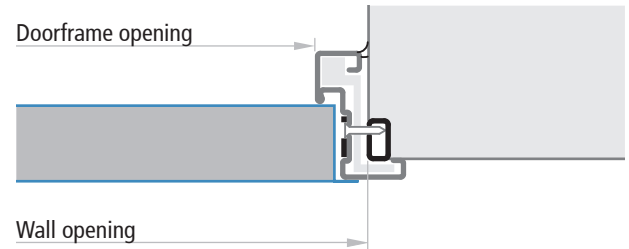
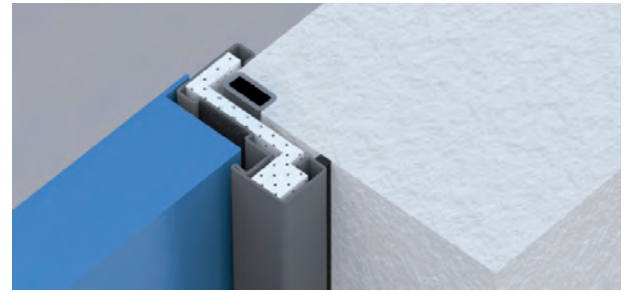

## INSTALLATION FOR EXPANSION SCREWS FIXING

Installation method certified for: one- or two-leaved EI<sub>2</sub>60, REI 60, REI 120, EI<sub>2</sub>90 two-leaved and EI<sub>2</sub>120 one-leaved doors, for expansion screws. Designed for installations onto blockwork, masonry or homogenous concrete wall, with density of (1200±400)kg/m<sup>3</sup> and a thickness of (200±50)mm.

The supplied doorframe comes factory heat-insulated with special materials and includes corner joints and a lower spacer (except for one-leaved doors with frame on four sides) to be added on site.

This method allows for "dry wall" installation of the doors without requiring any additional masonry work. Installation of the door, therefore, becomes a simple mechanical operation plus the final adjustments.

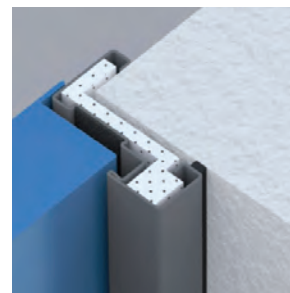

EI<sub>2</sub>60, REI 60 and REI 120 doors



EI<sub>2</sub>90, EI<sub>2</sub>120 doors

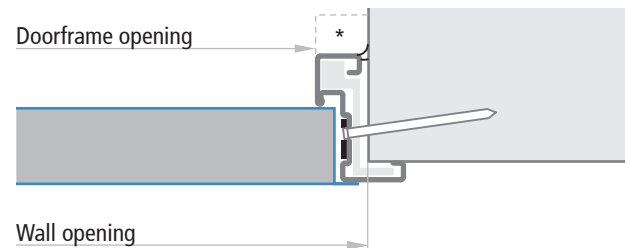

### NOTE

Please specify clearly whether the door is for subframe installation or for direct wall installation with expansion screws.

\* concealing with concrete mandatory for EI<sub>2</sub>90 and EI<sub>2</sub>120 fire-rated doors.

## WALL SCREWS

For direct wall installations or installation onto subframes, special expansion screws should be used without plugs. Please see the "door accessories" pages for more details.



## BLOCK FRAME FOR IN THE REVEAL APPLICATION

Installation method certified for one- and two-leaved EI<sub>2</sub>60, one-leaved EI<sub>2</sub>120 or two-leaved EI<sub>2</sub>90 doors. The supplied frame comes factory heat-insulated with special materials and includes corner joints and pre-drilled screw holes on the rebate. Installation for expansion screws (not supplied). This method allows for "dry wall" installation of the doors without requiring any additional masonry work. Installation of the door, therefore, becomes a simple mechanical operation plus the final adjustments.

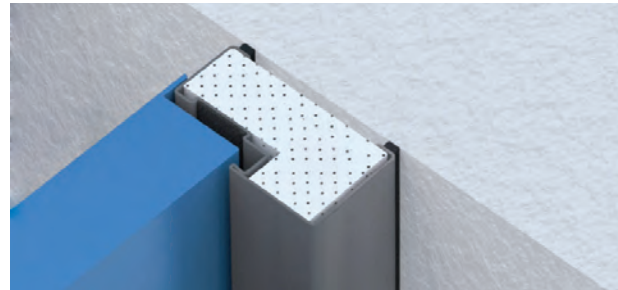

### ATTENTION

Acoustic performance values are not valid in case of block frame for in the reveal application.

## DOOR CROSS SECTIONS - MEASUREMENTS

### One-leaved doors

Horizontal cross section

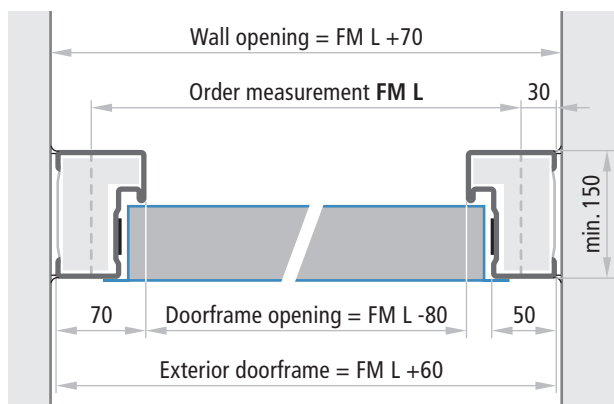

### Doors without lower threshold

Vertical cross section

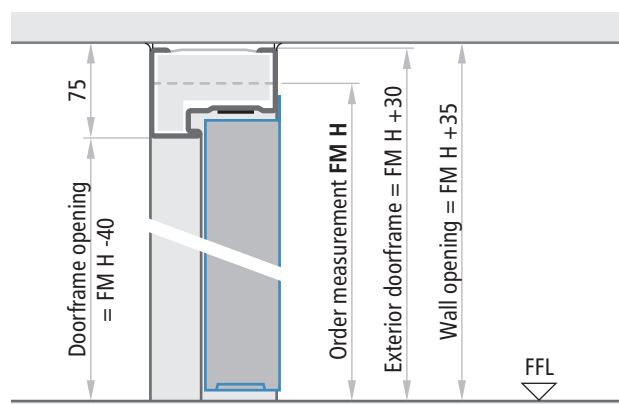

### Two-leaved doors

Horizontal cross section

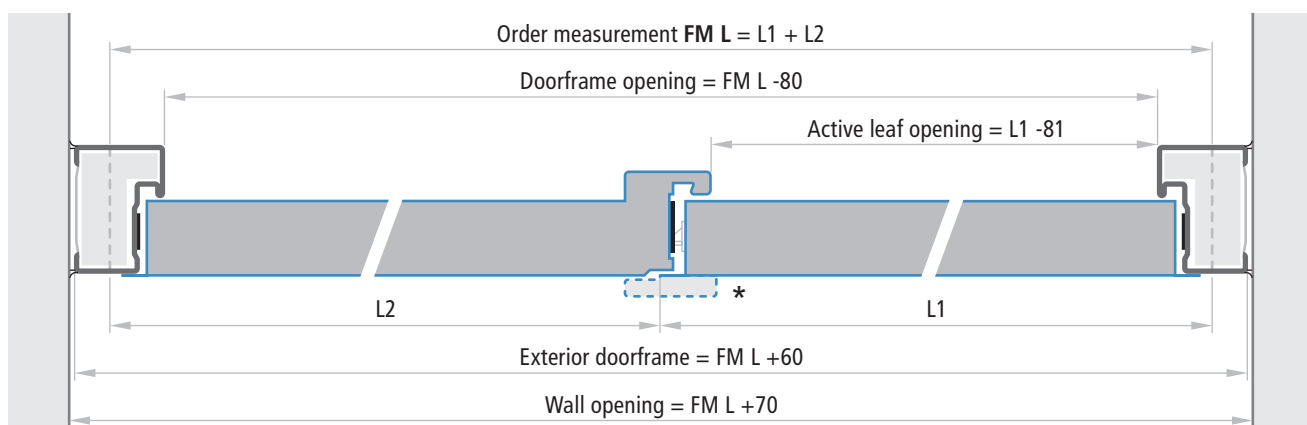

### NOTE

- Expansion screws recommended:
- for light wall Würth type DBL-(WUS-SK)-Z3-180-10x202
  - for heavy wall Spit type L 10 - 102/152

(\*) Proget EI<sub>2</sub>90 two leaved doors feature an additional isolated central rebate profile, which is applied onto the active leaf.

## LIGHTWEIGHT CONSTRUCTION INSTALLATION WITH EMBRACING FRAME

Installation method onto lightweight constructions certified for one- or two-leaved doors. The supplied frame comes factory heat-insulated with special materials and includes corner joints and pre-drilled screw holes with cover caps.

Door cross section and lightweight construction version: **E<sub>1,60</sub>**

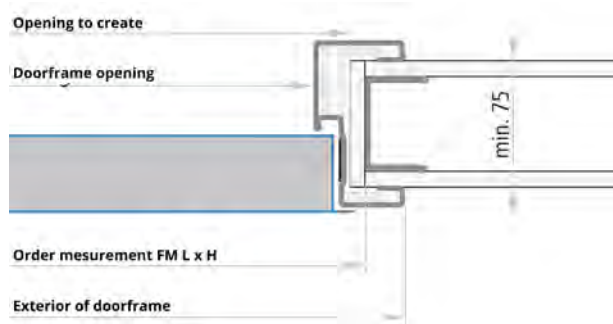

Door cross section and plasterboard version: **REI 60**

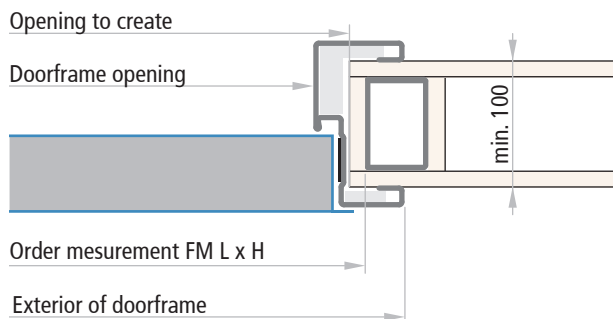

Door cross section and plasterboard version: **REI 120 E<sub>1,60</sub> - E<sub>1,120</sub>**

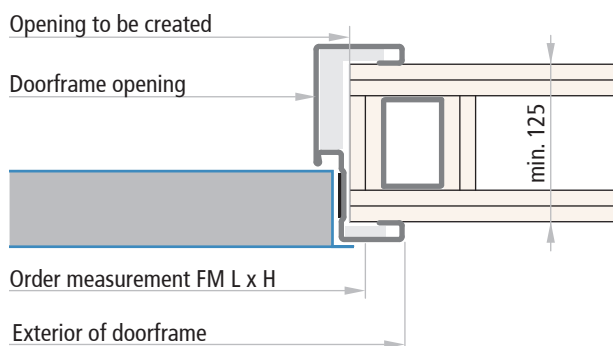

### Lightweight constructions E<sub>1,60</sub>, E<sub>1,90</sub>, E<sub>1,120</sub>

Made using galvanized steel frames with "U"-shaped 75x40mm min. guide profiles, "C"-shaped 50x47mm min. vertical profiles (doubled next to the doorframe), with a single layer of 12,5mm min. thick fire rated plasterboard used as finishing on both sides and on the profiles around the doorframe.

| Order measurement    | required wall opening | doorframe opening | exterior of doorframe |
|----------------------|-----------------------|-------------------|-----------------------|
| <b>FM L (width)</b>  | FM L - 25 mm          | FM L - 80 mm      | FM L + 60 mm          |
| <b>FM H (height)</b> | FM H - 12 mm          | FM H - 40 mm      | FM H + 30 mm          |

#### NOTE

Lightweight constructions should be done following the specific door installation instructions.

### Plasterboard walls REI 60

Made using galvanized steel frames with "U"-shaped 75x40mm min. guide profiles, "C"-shaped 75x47mm min. vertical profiles (doubled next to the doorframe), with a single layer of 12,5mm min. thick fire rated plasterboard used as finishing on both sides and on the profiles around the doorframe.

| Order measurement    | Required wall opening | Doorframe opening | Exterior of doorframe |
|----------------------|-----------------------|-------------------|-----------------------|
| <b>FM L (width)</b>  | FM L - 25 mm          | FM L - 80 mm      | FM L + 60 mm          |
| <b>FM H (height)</b> | FM H - 12 mm          | FM H - 40 mm      | FM H + 30 mm          |

### Plasterboard walls E<sub>1,90</sub>, E<sub>1,120</sub> and REI 120

Made using galvanized steel framing with "U"-shaped 75x40mm min. guide profiles, "C"-shaped 75x47mm min. vertical profiles (doubled next to the doorframe), with a double layer of 12,5mm min. thick fire rated plasterboard used as finishing on both sides and on the profiles around the doorframe.

| Order measurement    | required wall opening | doorframe opening | exterior of doorframe |
|----------------------|-----------------------|-------------------|-----------------------|
| <b>FM L (width)</b>  | FM L - 25 mm          | FM L - 80 mm      | FM L + 60 mm          |
| <b>FM H (height)</b> | FM H - 12 mm          | FM H - 40 mm      | FM H + 30 mm          |

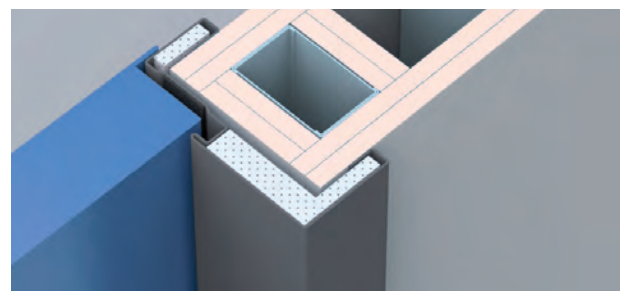

# Order measurements

PROGET Fire doors



## ORDER MEASUREMENTS

### Wall opening

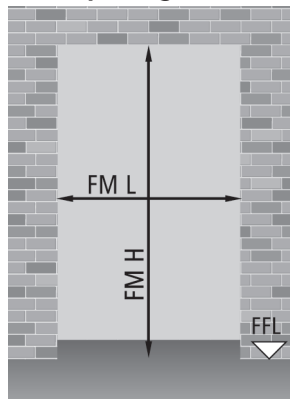

### Doorframe opening

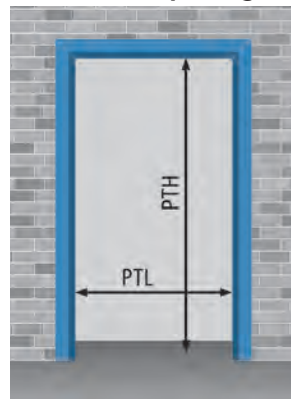

$$PTL = FM L - 80$$

$$PTH = FM H - 40$$

### Lightweight constructions wall opening

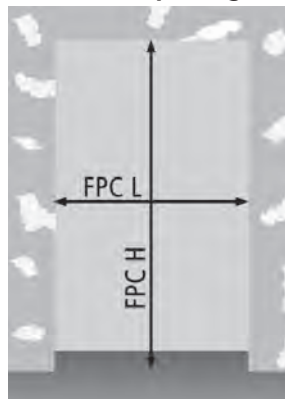

$$FPC L = FM L - 25$$

$$FPC H = FM H - 12$$

### Block frame opening

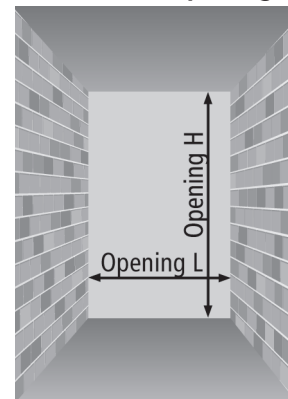

$$\text{Opening L} = FM L + 70$$

$$\text{Opening H} = FM H + 35$$

#### NOTE

The wall openings to be created for the embracing frame or the block frame for in the reveal application, do not correspond to the order measurement and therefore should follow the above specifications.

### One-leaved doors

| FM L x FM H<br>standard dimensions      | PT L x PT H (doorframe opening)<br>frame on 3 sides |   | fire-rating<br>class                                     |
|---|---|---|--|
|   | frame on 3 sides                                    | frame on 4 sides                        |  |
| 800 x 2000 / 2050 / 2100 / 2150 / 2200  | 720 x 1960 / 2010 / 2060 / 2110 / 2160              | 720 x 1940 / 1990 / 2040 / 2090 / 2140  | EI <sub>2</sub> 60, EI <sub>2</sub> 120, REI 60, REI 120 |
| 900 x 2000 / 2050 / 2100 / 2150 / 2200  | 820 x 1960 / 2010 / 2060 / 2110 / 2160              | 820 x 1940 / 1990 / 2040 / 2090 / 2140  | EI <sub>2</sub> 60, EI <sub>2</sub> 120, REI 60, REI 120 |
| 1000 x 2000 / 2050 / 2100 / 2150 / 2200 | 920 x 1960 / 2010 / 2060 / 2110 / 2160              | 920 x 1940 / 1990 / 2040 / 2090 / 2140  | EI <sub>2</sub> 60, EI <sub>2</sub> 120, REI 60, REI 120 |
| 1100 x 2050 / 2100 / 2150 / 2200        | 1020 x 2010 / 2060 / 2110 / 2160                    | 1020 x 1990 / 2040 / 2090 / 2140        | EI <sub>2</sub> 60, EI <sub>2</sub> 120, REI 60, REI 120 |
| 1200 x 2050 / 2100 / 2150 / 2200        | 1120 x 2010 / 2060 / 2110 / 2160                    | 1120 x 1990 / 2040 / 2090 / 2140        | EI <sub>2</sub> 60, EI <sub>2</sub> 120, REI 60, REI 120 |
| 1300 x 2000 / 2050 / 2100 / 2150 / 2200 | 1220 x 1960 / 2010 / 2060 / 2110 / 2160             | 1220 x 1940 / 1990 / 2040 / 2090 / 2140 | EI <sub>2</sub> 60, EI <sub>2</sub> 120, REI 60, REI 120 |
| 1340 x 2050 / 2100 / 2150 / 2200        | 1260 x 2010 / 2060 / 2110 / 2160                    | 1260 x 1990 / 2040 / 2090 / 2140        | EI <sub>2</sub> 60, EI <sub>2</sub> 120, REI 60, REI 120 |
| <b>non-standard dimensions</b>          |   |   |  |
| from 670 to 1340 x from 1950 to 2600    | from 590 to 1260 x from 1910 to 2560                | from 590 to 1260 x from 1890 to 2540    | EI <sub>2</sub> 60                                       |
| from 710 to 1340 x from 1900 to 2640    | from 630 to 1260 x from 1860 to 2600                | from 630 to 1260 x from 1840 to 2580    | EI <sub>2</sub> 120                                      |
| from 546 to 1340 x from 1775 to 2670    | from 466 to 1260 x from 1735 to 2630                | from 466 to 1260 x from 1715 to 2610    | REI 60, REI 120<br>anchor fixing                         |
| from 546 to 1170 x from 1775 to 2275    | from 520 to 1090 x from 1735 to 2235                | from 520 to 1090 x from 1715 to 2215    | REI 60, REI 120<br>embracing frame                       |
| from 1004 to 1340 x from 2050 to 2500   | from 924 to 1260 x from 2010 to 2460                | from 924 to 1260 x from 1990 to 2440    | REI 60, REI 120<br>embracing frame                       |
| from 546 to 1170 x from 1775 to 2275    | from 520 to 1090 x from 1735 to 2235                | from 520 to 1090 x from 1715 to 2215    | REI 60, REI 120<br>subframe or expansion screw           |
| from 1004 to 1340 x from 2050 to 2500   | from 924 to 1260 x from 2010 to 2460                | from 924 to 1260 x from 1990 to 2440    | REI 60, REI 120<br>subframe or expansion screw           |

# Order measurements - Handle height

PROGET Fire doors

**NINZ**  
FIRE DOORS

PROGET  
fire doors

| Two-leaved doors FM L x FM H |               |   |                                  | PT L x PT H                             | fire-rating                   |
|------------------------------|---------------|---|----------------------------------|---|-------------------------------|
| standard dimensions          |               |   |                                  | doorframe opening                       | class                         |
| 1150                         | ( 800 + 350)  | x | 2000 / 2050 / 2100 / 2150 / 2200 | 1070 x 1960 / 2010 / 2060 / 2110 / 2160 | EI,60, REI 60, REI 120        |
| 1200                         | ( 800 + 400)  | x | 2000 / 2050 / 2100 / 2150 / 2200 | 1120 x 1960 / 2010 / 2060 / 2110 / 2160 | EI,60, REI 60, REI 120        |
| 1250                         | ( 800 + 450)  | x | 2000 / 2050 / 2100 / 2150 / 2200 | 1170 x 1960 / 2010 / 2060 / 2110 / 2160 | EI,60, REI 60, REI 120        |
| 1250                         | ( 900 + 350)  | x | 2000 / 2050 / 2100 / 2150 / 2200 | 1170 x 1960 / 2010 / 2060 / 2110 / 2160 | EI,60, REI 60, REI 120        |
| 1300                         | ( 900 + 400)  | x | 2000 / 2050 / 2100 / 2150 / 2200 | 1220 x 1960 / 2010 / 2060 / 2110 / 2160 | EI,60, REI 60, REI 120        |
| 1350                         | ( 900 + 450)  | x | 2000 / 2050 / 2100 / 2150 / 2200 | 1270 x 1960 / 2010 / 2060 / 2110 / 2160 | EI,60, REI 60, REI 120        |
| 1350                         | (1000 + 350)  | x | 2000 / 2050 / 2100 / 2150 / 2200 | 1270 x 1960 / 2010 / 2060 / 2110 / 2160 | EI,60, REI 60, REI 120        |
| 1400                         | (1000 + 400)  | x | 2000 / 2050 / 2100 / 2150 / 2200 | 1320 x 1960 / 2010 / 2060 / 2110 / 2160 | EI,60, REI 60, REI 120        |
| 1450                         | (1000 + 450)  | x | 2000 / 2050 / 2100 / 2150 / 2200 | 1370 x 1960 / 2010 / 2060 / 2110 / 2160 | EI,60, REI 60, REI 120        |
| 1600                         | ( 800 + 800)  | x | 2000 / 2050 / 2100 / 2150 / 2200 | 1520 x 1960 / 2010 / 2060 / 2110 / 2160 | EI,60, EI,90, REI 60, REI 120 |
| 1700                         | ( 900 + 800)  | x | 2000 / 2050 / 2100 / 2150 / 2200 | 1620 x 1960 / 2010 / 2060 / 2110 / 2160 | EI,60, EI,90, REI 60, REI 120 |
| 1800                         | ( 900 + 900)  | x | 2000 / 2050 / 2100 / 2150 / 2200 | 1720 x 1960 / 2010 / 2060 / 2110 / 2160 | EI,60, EI,90, REI 60, REI 120 |
| 1800                         | (1000 + 800)  | x | 2000 / 2050 / 2100 / 2150 / 2200 | 1720 x 1960 / 2010 / 2060 / 2110 / 2160 | EI,60, EI,90, REI 60, REI 120 |
| 1900                         | (1000 + 900)  | x | 2000 / 2050 / 2100 / 2150 / 2200 | 1820 x 1960 / 2010 / 2060 / 2110 / 2160 | EI,60, EI,90, REI 60, REI 120 |
| 2000                         | (1000 + 1000) | x | 2000 / 2050 / 2100 / 2150 / 2200 | 1920 x 1960 / 2010 / 2060 / 2110 / 2160 | EI,60, EI,90, REI 60, REI 120 |

## non-standard dimensions

|   |   |                   |                   |   |                   |   |
|---|---|-------------------|-------------------|---|-------------------|---|
| from 890 (540 + 350) to 2540 (1270 + 1270)  | x | from 1775 to 2600 | from 810 to 2460  | x | from 1735 to 2560 | EI,60                                       |
| from 1175 (600 + 575) to 2540 (1270 + 1270) | x | from 1775 to 2300 | from 1095 to 2460 | x | from 1735 to 2260 | EI,90                                       |
| from 1175 (600 + 575) to 2500 (1250 + 1250) | x | from 2301 to 2500 | from 1095 to 2420 | x | from 2261 to 2460 | EI,90                                       |
| from 1175 (600 + 575) to 2380 (1200 + 1180) | x | from 2501 to 2630 | from 1095 to 2300 | x | from 2461 to 2590 | EI,90                                       |
| from 890 (540 + 350) to 2540 (1270 + 1270)  | x | from 1775 to 2670 | from 810 to 2460  | x | from 1735 to 2630 | REI 60, REI 120 anchor fixing               |
| from 890 (540 + 350) to 2298 (1164 + 1134)  | x | from 1775 to 2275 | from 810 to 2218  | x | from 1735 to 2235 | REI 60, REI 120 embracing frame             |
| from 1962 (996 + 966) to 2540 (1270 + 1270) | x | from 2050 to 2500 | from 1882 to 2460 | x | from 2010 to 2460 | REI 60, REI 120 embracing frame             |
| from 890 (540 + 350) to 2298 (1164 + 1134)  | x | from 1775 to 2275 | from 810 to 2218  | x | from 1735 to 2235 | REI 60, REI 120 subframe or expansion screw |
| from 1962 (996 + 966) to 2540 (1270 + 1270) | x | from 2050 to 2500 | from 1882 to 2460 | x | from 2010 to 2460 | REI 60, REI 120 subframe or expansion screw |

The following doors are equipped with a CP1 door closer:

EI<sub>2</sub>90 2 leaves: L1 > 1150

L2 > 1120 x from 2151 to 2300  
(L1 or L2) > 900 x from 2301 to 2630

EI<sub>2</sub>120 1 leaf: > 1125 x from 2301 to 2500  
> 900 x from 2501 to 2640

REI 120 1 leaf: > 1125 x from 2301 to 2500  
> 900 x from 2501 to 2670

2 leaves: (L1 or L2) > 1125 x from 2151 to 2300  
(L1 or L2) > 900 x from 2301 to 2670

Measures refer to leaves width and height

## HANDLE HEIGHT

### One-leaved door

h = 1050 (FM H ≥ 1750)

Different heights available upon request only



### Two-leaved door

h = 1050 (FM H ≥ 1750)

Different heights available upon request only



# Opening measurements - Overall dimensions

PROGET fire doors



PROGET fire doors

## OPENING MEASUREMENTS AND OVERALL DIMENSIONS WITH 90 DEGREE OPENING

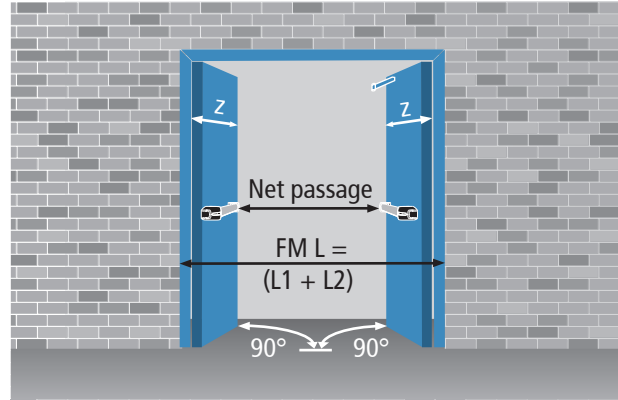
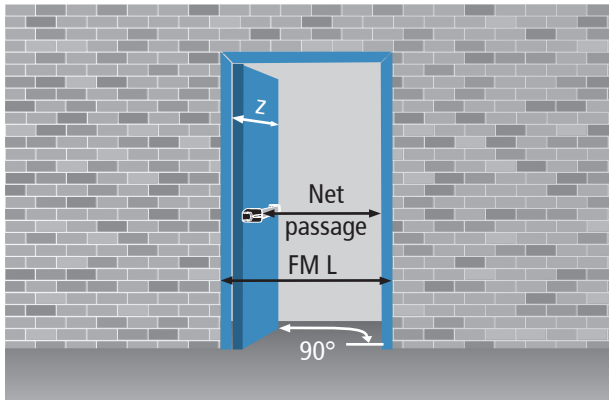

### Net passage calculation

| panic bar type                           | protrusion | one-leaved door | two-leaved door   | one-leaved door with block frame | two-leaved door with block frame |
|--|------------|-----------------|---|----------------------------------|----------------------------------|
| EXUS                                     | 125        | FML - 245       | FML - 410   | Opening - 315                    | Opening - 480                    |
| TWIST                                    | 100        | FML - 220       | FML - 360   | Opening - 290                    | Opening - 430                    |
| SLASH                                    | 75         | FML - 195       | FML - 310   | Opening - 265                    | Opening - 380                    |
| FAST TOUCH                               | 75         | FML - 195       | FML - 310   | Opening - 265                    | Opening - 380                    |
| without panic bar                        | -          | FML - 120       | FML - 160   | Opening - 190                    | Opening - 230                    |
| z = leaf protrusion relative to the wall |            | FML + 27        | EI,60, REI 60, REI 120 = L1 + 35, L2 + 75; EI,90 = L1 + 67, L2 + 75 |                                  |                                  |

## OVERALL DIMENSIONS WITH 180 DEGREE OPENING

### One-leaved door

$x = FML - 7$

### Two-leaved door

$EI_{2,60}, REI 60, REI 120: x = L1 + 1; EI_{2,90}: x = L1 + 33; y = L2 + 42$   
 $b = \max. 130$  (only in the presence of a panic bar or M14 handle)

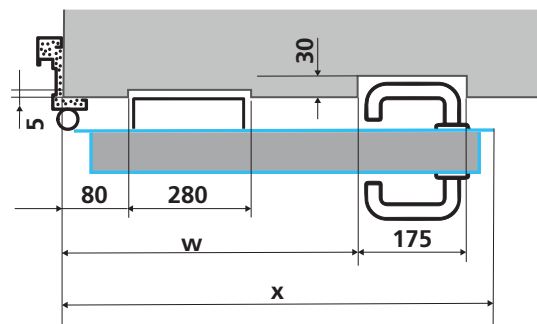
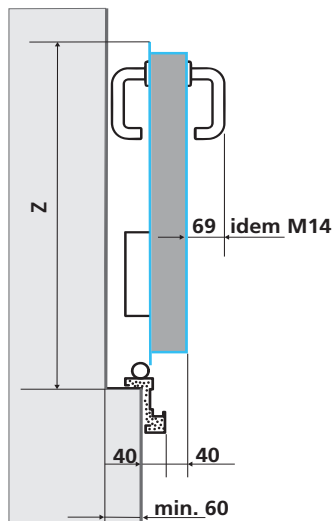
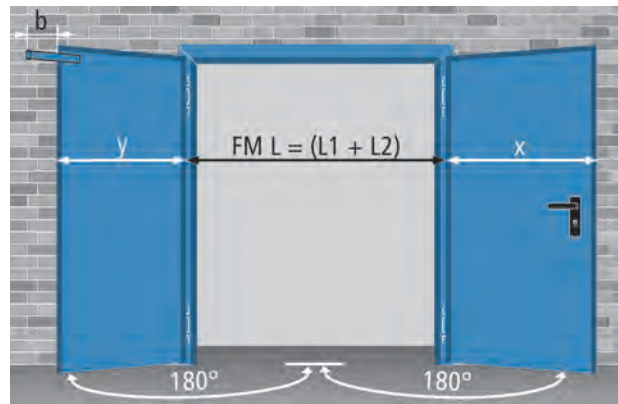

**"bare minimum, maximum performance!"**





## **NINZ REVER multipurpose doors**

|  |                |
|--|----------------|
| <b>FEATURES</b>                                  | <b>62 - 65</b> |
| <b>SPECIFIC OPTIONAL ACCESSORIES</b>             | <b>66 - 69</b> |
| <b>DOOR CROSS SECTIONS - MEASUREMENTS</b>        | <b>70</b>      |
| <b>INSTALLATION METHODS</b>                      | <b>71</b>      |
| <b>ORDER MEASUREMENTS</b>                        | <b>72</b>      |
| <b>OPENING MEASUREMENTS - OVERALL DIMENSIONS</b> | <b>73</b>      |

# Features

## REVER multipurpose doors

### THE ECONOMICAL MULTIPURPOSE YOU ALWAYS WISHED FOR

#### “Quality first”

- Fully galvanized, including the “hidden” parts
- Made of “Sendzimir” processed hot-galvanized sheet metal
- Corrosion protection also provided along the cut edges of the metal
- Painted with epoxy-polyester thermoset powders in a 180 degree (Celsius) oven
- Extra-thick paint layer (over 70 microns)
- Optimal corrosion resistance as demonstrated by 500 hour salt-fog testing
- Finishing with high-quality aesthetics
- Orange skin anti-scratch structured paint
- Customizable with wide selection of RAL colors

#### “Practicality of use”

- Door reversibility
- Indication of door opening direction not necessary
- Reduction of stock for retailers
- Simplifies choices for end customers
- Especially well-suited for indoor use
- Light but still sturdy
- Easy installation

#### “Versatility”

- Very wide field of application
- Can be combined with various frame types
- Installable onto any wall type
- Application with a block frame
- Can be combined with over-head frame panel with or without ventilating perforation
- Available with upper/lower crack enlargement
- Vast assortment of accessories
- Customized measurements also available

#### “Manufacturing technology”

- Manufacturing in modern and functional facilities which employ the latest technologies to maintain high quality levels and product uniformity
- The entire production process - from raw materials to painted and packaged products - takes place inside Ninz’s own facilities, ensuring a 360 degree door control



One-leaved doors



Two-leaved doors

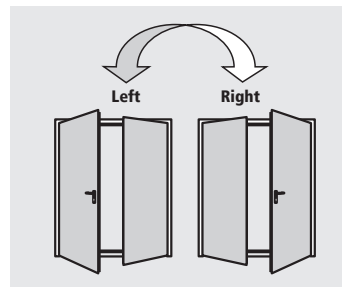
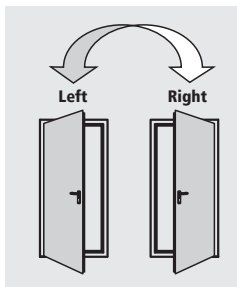

# Features

## REVER multipurpose doors

### STANDARD ELEMENTS

#### Door

- Made of "Sendzimir" processed hot-galvanized sheet metal, press folded
- Perimetral rebate on 4 sides
- Internal corrugated honeycomb fiber structure fixed firmly to the sheet metal
- Thickness of 40mm

#### Doorframe

- Made of "Sendzimir" processed hot-galvanized sheet metal
- Grooves for rebate sealing
- Suitable for anchors for mortar fixing or expansion screws
- Detachable rebate for application on finished flooring
- Removable threshold for thresholdless installation
- Strike plates in black plastic for lock bolt
- Assembled doorframes for one-leaved doors
- Assembly required for two-leaved doorframes

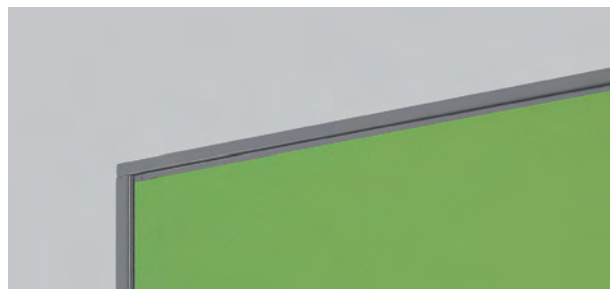

#### Hinges

- Nr. 2 three-wing hinges for each leaf

#### Locking mechanism

- Reversible locking mechanism with bolt and central latch
- Insert with patent key, Euro profile cylinder ready

#### Handle

- Black plastic handle
- Fastener screws to pass
- Insert for patent-type key

#### Safety bolts

- Nr. 3 safety bolts applied on hinge side doorframe edge

# Features

## REVER multipurpose doors



REVER  
multipurpose

### INCLUDED ACCESSORIES

#### Safety lock

- Central latch for blocking and unblocking the inactive leaf
- Lever control for unlocking vertical rods

#### Upper coupling system for the inactive leaf

- Vertical rod with steel point which inserts into the upper strike box
- Upper strike box in black plastic with steel roller

#### Lower coupling system for the inactive leaf

- Vertical rod with steel point which inserts into lower strike box
- Floor catch (floor-mounted bushing) in black plastic, for doors without threshold
- Floor catch in black plastic with a steel roller, for doors with threshold



Standard paint - group 01: RAL 9010

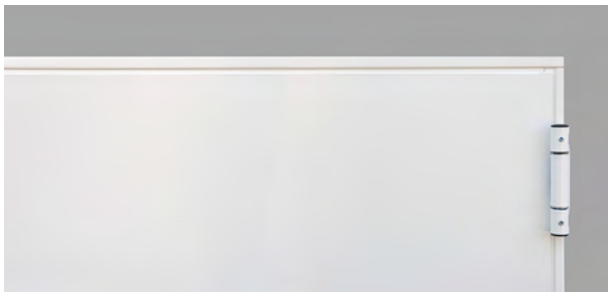

#### Finishing

- Standard painted with epoxy-polyester thermoset powders in a 180 degrees oven, orange skin, anti-scratch finishing
- Standard paint RAL 9010

#### Standard packaging

- Single door wrapped into stretchable polyethylene (PE) film
- Assembled doorframes for one-leaved doors
- Assembly required for doorframes for two-leaved doors
- Palletized on wooden pallets

#### Pre-settings

- The main lock and upper rod housing on the inactive leaf are ready for installation of the latching mechanism for panic bars

#### NOTE

If the door ever needs to be repainted, follow the precise instructions on the "Painting" page.

**OPTIONAL ACCESSORIES**

A wide variety of accessories and surface finishes are available on request for maximum value enhancement of Rever doors to your own specific needs.

The proper accessories can help resolve:

**Safety-related needs**

- Doors for panic exits (see panic bars)
- Doors for emergency exits (see emergency exit handles)
- Three-point Rever SECUR lock

**Installation and utilization needs**

- Embracing or telescopic frames
- Frame extensions
- Drip steel-profile
- Kick and protection plates in stainless steel
- Windows
- Ventilating perforation
- Overhead frame panel
- Available with upper/lower crack enlargement

**Access-related control issues**

- Electrically-activated lock mechanisms
- Electric handle mechanisms
- Magnetic blocking mechanisms

**Performance enhancing**

- Rebate sealings
- Cylinders
- Door closers
- Special handles



**NOTE**

Details about optional accessories may be found in the following chapters of this brochure:

- Painting
- Accessories for metal doors
- Emergency handles and panic bars

Right-opening doors are the default selection if opening direction is not specified.

**Customized finishing**

- Select finishing from a wide variety of RAL colours
- Stainless steel handles
- Colored handles

**Packaging for maximum protection**

Sturdy wooden crates protect all doors and related accessories

- On construction sites
- During shipping abroad
- For special transport

The following optional accessories make Rever doors irreversible, requiring the indication of the door opening direction when the order is placed:

- SLASH panic bar
- Panic bar for inactive leaves
- Windows and ventilation grills
- MAC locks
- ELM/cisa and ELM/mt electric handle
- Special locks (016 tir)
- Overhead frame panels and prolonged frames
- Special doorframes (SPEED, SOLID, TESCOP)

# Specific optional accessories

## REVER multipurpose doors

### MULTIPURPOSE WINDOW

On request, the one- and two-leaved doors may be equipped with round or rectangular windows, with stratified 3 + 3 mm glass, 2B2 rated, framed with a black rubber EPDM profile. The corners of rectangular windows are rounded (radius of approx. 100 mm).

#### Production limits

Window sizes are standard and the minimum border strips around the window may not be reduced.

#### Borders, window position

"Border measurement" refers to the distance from the edge of the window to the wall opening of the door.

#### Elevation for round windows

| window size | FM H           | position     |
|-------------|----------------|--------------|
| Ø 300       | minimum 1950   | Y=1600       |
| Ø 300       | less than 1950 | Y=FM H - 350 |
| Ø 400       | minimum 2000   | Y=1600       |
| Ø 400       | less than 2000 | Y=FM H - 400 |

#### Elevation for rectangular windows

| window dimensions L x H | FM H           | position     |
|-------------------------|----------------|--------------|
| 300 x 500               | minimum 1950   | Z=1500       |
| 300 x 500               | less than 1950 | Z=FM H - 450 |
| 400 x 700               | minimum 2050   | Z=1500       |
| 400 x 700               | less than 2050 | Z=FM H - 550 |



#### KIT window

The windows for Rever doors are also available as a KIT for later installation directly by the customer.

#### NOTE

The positions indicated above are those standard. Different positions may be considered as long as they respect the minimum "a" and "b" border strips.



#### Round and rectangular window cross sections

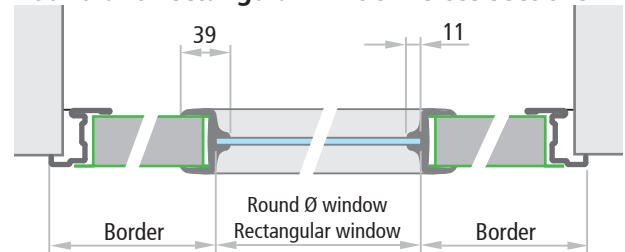

#### Window dimensions

|  |           | minimum border |     | FM L min. dimensions |
|--|-----------|----------------|-----|----------------------|
|  |           | a              | b   |                      |
|  | Ø 300     | 200            | 200 | 700                  |
|  | Ø 400     | 200            | 200 | 800                  |
|  | Ø 300     | 200            | 200 | L1 700 + L2 400      |
|  | Ø 400     | 200            | 200 | L1 800 + L2 400      |
|  | Ø 300     | 200            | 200 | L1 700 + L2 700      |
|  | Ø 400     | 200            | 200 | L1 800 + L2 800      |
|  | 300 x 500 | 200            | 200 | 700                  |
|  | 400 x 700 | 200            | 200 | 800                  |
|  | 300 x 500 | 200            | 200 | L1 700 + L2 400      |
|  | 400 x 700 | 200            | 200 | L1 800 + L2 400      |
|  | 300 x 500 | 200            | 200 | L1 700 + L2 700      |
|  | 400 x 700 | 200            | 200 | L1 800 + L2 800      |

# Specific optional accessories

REVER multipurpose doors



REVER multipurpose

## SPECIAL ‚SPEED‘ DOORFRAME FOR REVER DOORS

SPEED on three sides embracing doorframe with 45 deg. joints, made of 1,25 mm thick galvanized „Sendzimir“ processed sheet metal, assembly required. For installation onto finished walls using 6 integrated clamps and two adjustable spacers with plugs or screws. Includes rebate sealing and RAL painting with thermoset epoxy-polyester powders. Minimum 80mm wall thickness, 55/70 frames.

| Order measurements | required wall opening | doorframe opening |
|--------------------|-----------------------|-------------------|
| FM L (width)       | FM L + 20             | FM L - 64         |
| FM H (height)      | FM H + 10             | FM H - 34         |

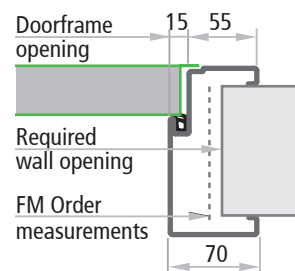

## SPECIAL ‚SOLID‘ DOORFRAME FOR REVER DOORS

SOLID on three sides embracing doorframe with 45 deg. joints, made of 1,25 mm thick galvanized „Sendzimir“ processed sheet metal, assembly required. For installation with anchors for mortar fixing or with fastening profiles to fix with plugs or screw on, including removable threshold spacer, sealing and RAL painting with thermoset epoxy-polyester powders. Minimum 50mm wall thickness, 45/45 frames.

| Order measurements | required wall opening | doorframe opening |
|--------------------|-----------------------|-------------------|
| FM L (width)       | FM L + 40             | FM L - 64         |
| FM H (height)      | FM H + 20             | FM H - 34         |

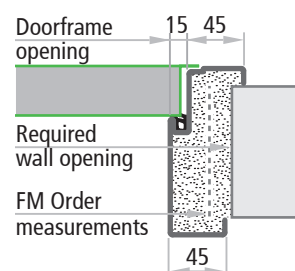

## SPECIAL ‚TESCOP‘ DOORFRAME FOR REVER DOORS

Two-pieced TESCOP on three sides embracing doorframe with 45 deg. joints, made of 1,25 mm thick galvanized „Sendzimir“ processed sheet metal, assembly required. To be fixed to finished wall with screws, including removable threshold spacer, sealing and RAL painting with thermoset epoxy-polyester powders. Minimum 80mm wall thickness, adjustment range of +25mm, frames 55/70.

| Order measurements | required wall opening | doorframe opening |
|--------------------|-----------------------|-------------------|
| FM L (width)       | FM L + 20             | FM L - 64         |
| FM H (height)      | FM H + 10             | FM H - 34         |

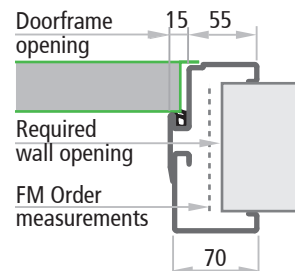

## INSTALLATION „IN THE REVEAL“ WITH BLOCK FRAME

On request additional block profiles for one- and two-leaved multipurpose Rever doors. Consists of 3 sections of hollow 40x20x1,5mm metal profiles painted the same color as the doorframe using thermoset epoxy-polyester powders. Installation with screws and plugs (screws and plugs not included).

Required wall opening = FM L + 36, FM H + 18

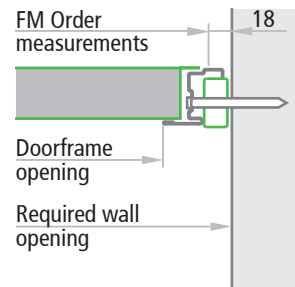
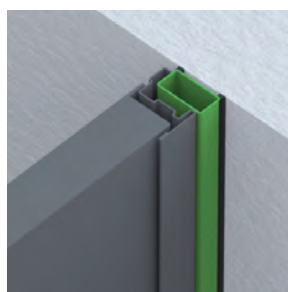

# Specific optional accessories

## REVER multipurpose doors

### VENTILATION LOUVER

Ventilation louver made of either black or white PVC, 482x99mm (air passage approx. 150cm<sup>2</sup>). The opening direction of the door needs to be specified.

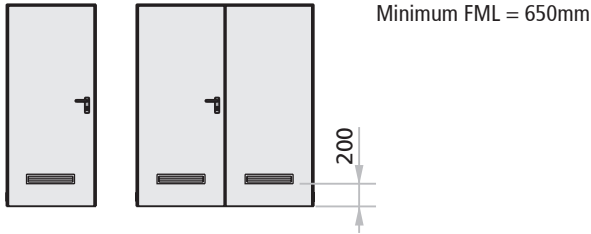

### VENTILATING PERFORATIONS

Ventilating perforation for one- and two-leaved Rever doors and for the active leaf of two-leaved doors; made by perforating the illustrated pattern into the sheet metal. Rever doors with ventilating perforations remain reversible.

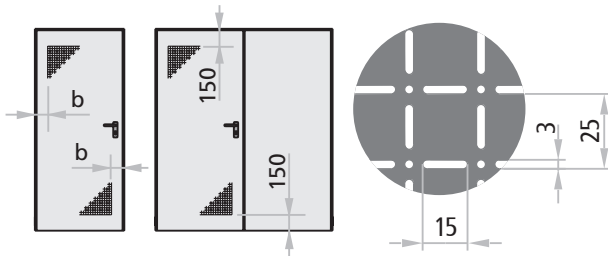

#### NOTE

Ventilating perforations are only provided on the active leaf of two-leaved doors.

| FM L / FM L1        | perforation  | aeration            | borders (b) |
|---------------------|--------------|---------------------|-------------|
| < 560 mm            | not possible | -                   | -           |
| from 560 to 700 mm  | 300 x 300 mm | 156 cm <sup>2</sup> | 100 mm      |
| from 701 to 1000 mm | 350 x 350 mm | 208 cm <sup>2</sup> | 100 mm      |
| > 1000 mm           | 350 x 350 mm | 208 cm <sup>2</sup> | 150 mm      |

### OVERHEAD FRAME PANEL

A prolonged frame with a galvanized, eventually perforated 12/10 mm thick piece of sheet metal to serve as the overhead frame panel with ventilating perforation, which also functions as the upper rebate for the leaf. Painted the same color as the leaf using thermoset epoxy-polyester powders. Also available for Speed, Solid and Tescop door-frames. Overhead panel delivered not mounted.

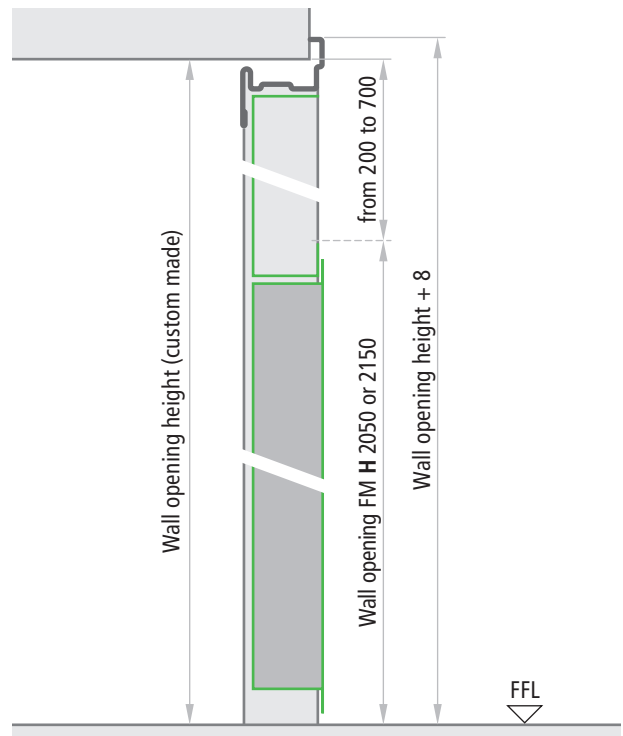
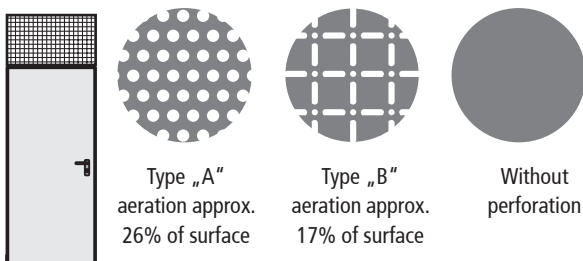

#### NOTE

The direction of panel's installation can be chosen by the customer.

# Specific optional accessories

REVER multipurpose doors



REVER multipurpose

## DOOR WITH EXTENDED FRAME

Frame extends beyond the door leaf to create a gap of height (h) varying of between 50 to 150 mm, either below or both above and below. When using the standard Rever door leaf and an extended frame, the positioning of the handle is higher as a consequence.

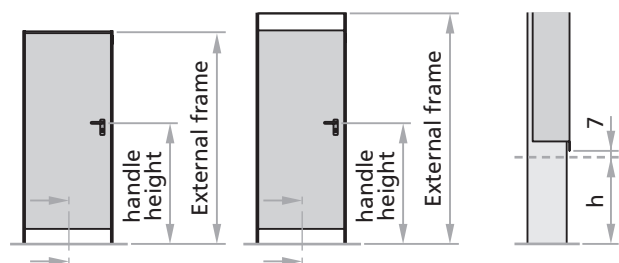

|                       | Handle height       | external frame     | required wall opening |
|-----------------------|---------------------|--------------------|-----------------------|
| crack below           | $FM H / 2 + 50 + h$ | $FM H + h + 8$     | $FM H + h$            |
| crack below and above | $FM H / 2 + 50 + h$ | $FM H + 2 x h + 8$ | $FM H + 2 x h$        |

### NOTE

The extended frame is also available as SPEED, SOLID or TESCOP version.

## THREE-POINT SECUR LOCK FOR REVER DOOR

The SECUR version of Rever provides a more reliable door closure. Activating the lock with a key blocks the leaf in the frame at three points: in the center with the latch bolt, above with the rod that inserts into the upper strike box and below with the rod that inserts into the lower strike box.

Also available as a KIT for on-site installation. SECUR Rever doors remain reversible.

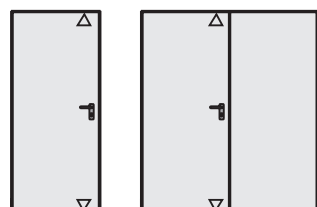

▷ Additional locking points



upper strike box



lower strike box (bushing)

### NOTE

Not available in the following versions: anti-panic, with overhead panel or with extended frame.

In case of SECUR version, the standard cylinder is supplied.

## IM21 FRAME EXTENSION FOR REVER DOORS

Frame extension to be screwed to the Rever doorframe acting as a wall cladding. Made of "Sendzimir" processed hot-galvanized sheet metal painted the same color as the doorframe with epoxy-polyester powders. Profile on three sides, upper corners with 90 degree joint.

To mount the frame extension, fixing holes need to be drilled into doorframe on site. Combine with sealing to conceal the screw heads.

Minimum 60mm wall thickness.



perimetral frame

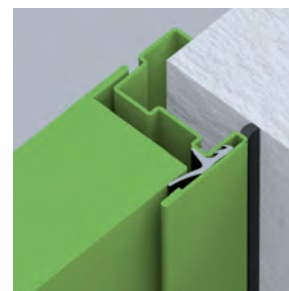

central joint for two-leaved doors

## REBATE SEALING CR

Sealing in black extruded profile to cut and to be pressed into the dedicated groove of the perimetral frame.

Sealing in black extruded profile self-adhesive to cut for application to the central joint of two-leaved doors.

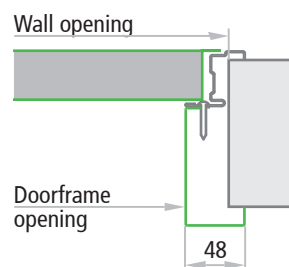
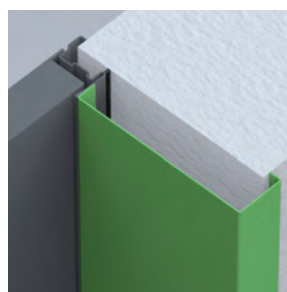

# Door cross sections - Measurements

REVER multipurpose doors



REVER  
multipurpose

## One-leaved doors

Horizontal cross section

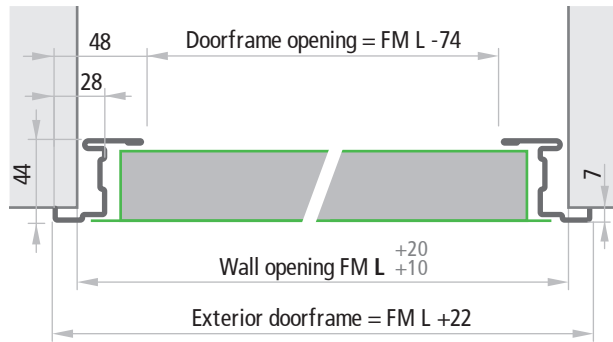

## Doors without lower threshold

Vertical cross section

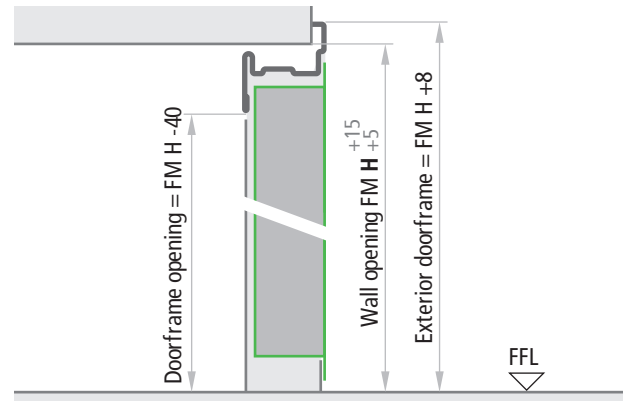

## Doors with internal and external lower threshold

Vertical cross section

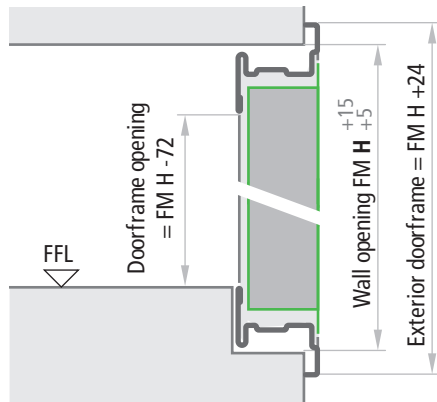

## Doors with internal lower threshold

Vertical cross section

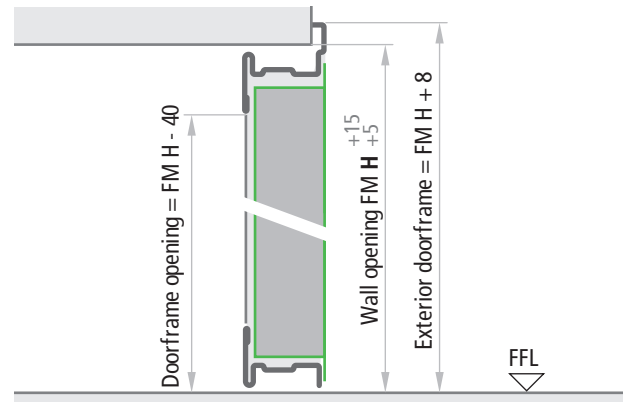

## Two-leaved doors

Horizontal cross section

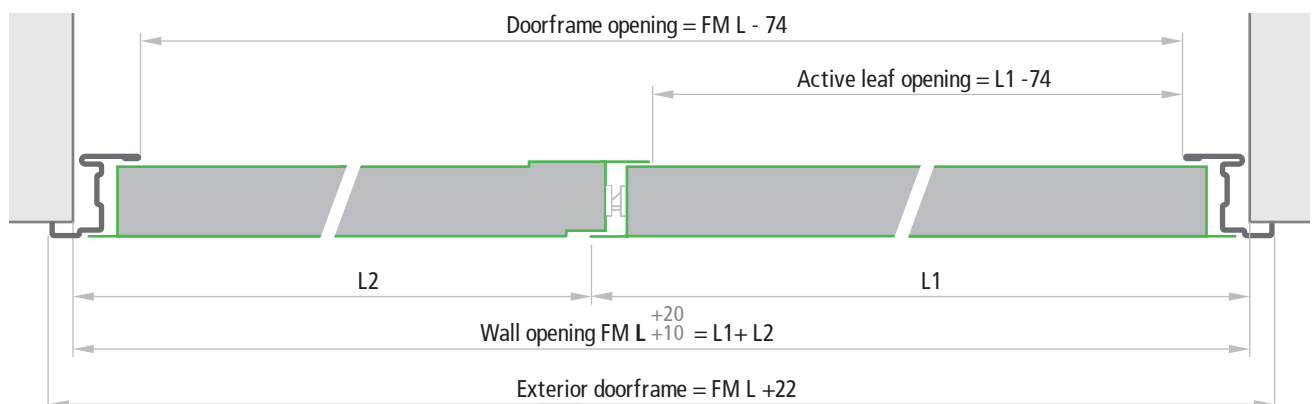

### Leaves thickness

MULTIPURPOSE 40 mm

### NOTE

The tolerances  $FM L +20$ ,  $FM H +5$  of the indicated measurements make it easier to fill the gap between the wall and the doorframe with cement mortar. For dry wall installation, the holes must be precise and greater tolerance ranges should not be employed.

# Installation methods

REVER multipurpose doors



REVER multipurpose

## INSTALLATION WITH ANCHORS FOR MORTAR FIXING

For mortar fixing, appropriate cuts will need to be created in the walls (section 80 x 160 mm) or the anchors should be fixed with expansion screws. The anchors should be bent and blocked inside the wall. For a perfect mechanical fit, the space between the doorframe and the masonry shall always be filled with concrete mortar or polyurethane foam.



## INSTALLATION FOR EXPANSION SCREWS FIXING

For the installation with expansion screws, the anchors serve as spacers and should not be bent. Using Würth type art. 0910436112 plugs or similar (supplied at the customer's expense), installation is done with expansion screws into the pre-drilled holes present on the frame. For a perfect mechanical fit, the space between the doorframe and the masonry shall always be filled with concrete mortar or polyurethane foam.

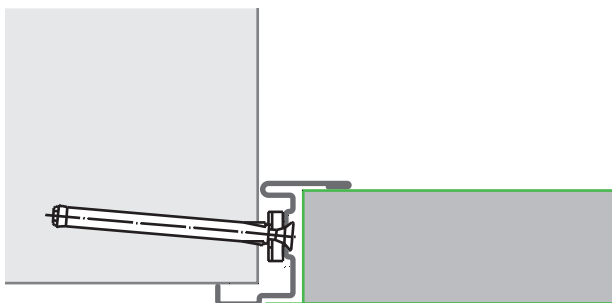

## ANCHOR POSITIONING

### One-leaved doors

Right opening and Left opening

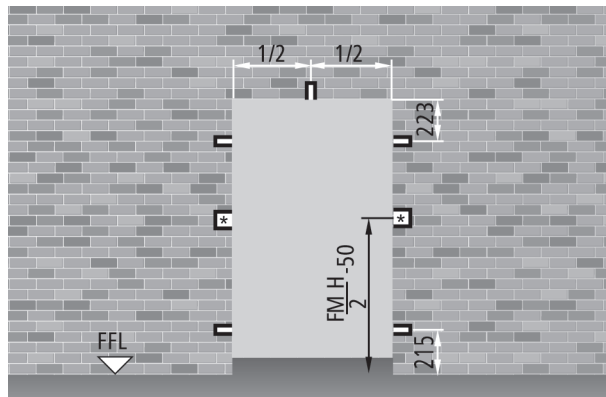

### Two-leaved doors

Right opening

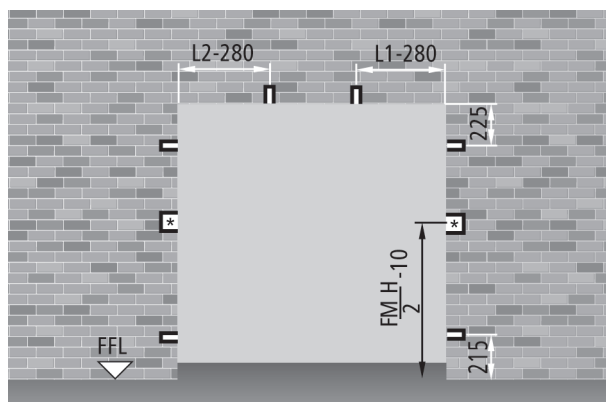

Left opening

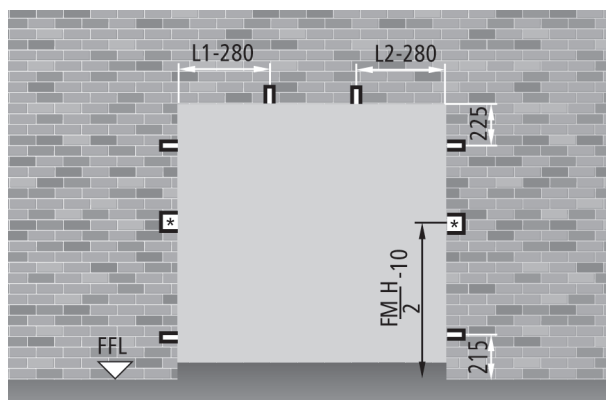

(\*) For proper installation, the cuts for the anchors should be 200 x 160 mm in size.

# Order measurements

## REVER multipurpose doors

### ORDER MEASUREMENTS

#### Wall Opening

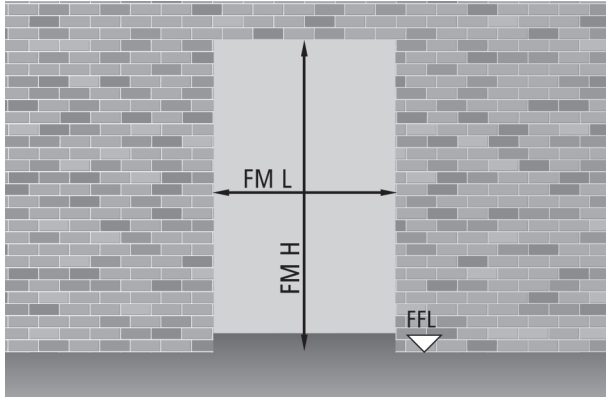

#### Doorframe opening

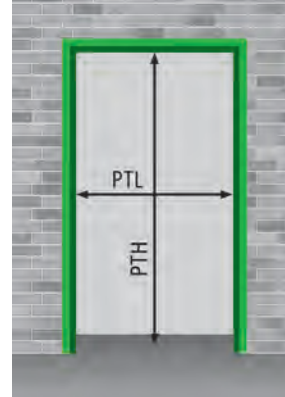

#### One-leaved doors

PTL = FML - 74  
PTH = FMH - 40

#### Two-leaved doors

PTL = FML - 74  
PTH = FMH - 40

#### One-leaved door FM L x FM H

##### standard dimensions

|      |   |                    |
|------|---|--------------------|
| 700  | x | 2050 / 2100 / 2150 |
| 800  | x | 2050 / 2100 / 2150 |
| 900  | x | 2050 / 2100 / 2150 |
| 1000 | x | 2050 / 2100 / 2150 |
| 1100 | x | 2050 / 2100 / 2150 |
| 1200 | x | 2050 / 2100 / 2150 |
| 1300 | x | 2050 / 2100 / 2150 |
| 1350 | x | 2050 / 2100 / 2150 |

#### PT L x PT H

##### doorframe opening

|      |   |                    |
|------|---|--------------------|
| 626  | x | 2010 / 2060 / 2110 |
| 726  | x | 2010 / 2060 / 2110 |
| 826  | x | 2010 / 2060 / 2110 |
| 926  | x | 2010 / 2060 / 2110 |
| 1026 | x | 2010 / 2060 / 2110 |
| 1126 | x | 2010 / 2060 / 2110 |
| 1226 | x | 2010 / 2060 / 2110 |
| 1276 | x | 2010 / 2060 / 2110 |

##### non-standard dimensions

from 500 to 1350 x from 1780 to 2200

from 526 to 1276 x from 1740 to 2160

#### Two-leaved doors FM L (L1+L2) x FM H

##### standard dimensions

|      |               |                      |
|------|---------------|----------------------|
| 1200 | ( 800 + 400)  | x 2050 / 2100 / 2150 |
| 1300 | ( 900 + 400)  | x 2050 / 2100 / 2150 |
| 1400 | ( 1000 + 400) | x 2050 / 2100 / 2150 |
| 1400 | ( 700 + 700)  | x 2050 / 2100 / 2150 |
| 1600 | ( 800 + 800)  | x 2050 / 2100 / 2150 |
| 1800 | ( 900 + 900)  | x 2050 / 2100 / 2150 |
| 2000 | (1000 + 1000) | x 2050 / 2100 / 2150 |

#### PT L x PT H

##### doorframe opening

|      |   |                    |
|------|---|--------------------|
| 1126 | x | 2010 / 2060 / 2110 |
| 1226 | x | 2010 / 2060 / 2110 |
| 1326 | x | 2010 / 2060 / 2110 |
| 1326 | x | 2010 / 2060 / 2110 |
| 1526 | x | 2010 / 2060 / 2110 |
| 1726 | x | 2010 / 2060 / 2110 |
| 1926 | x | 2010 / 2060 / 2110 |

##### non-standard dimensions

from 900 (500+400) to 2000 (1000+1000) x from 1780 to 2200

from 826 to 1926 x 1740 / 2160

#### NOTE

Unless specified otherwise by the customer, two-leaved standard and customized doors are supplied with a right-pull opening direction.

# Opening measurements - Overall dimensions

REVER multipurpose doors



REVER multipurpose

## OPENING MEASUREMENTS AND OVERALL DIMENSIONS WITH 90 DEGREE OPENING

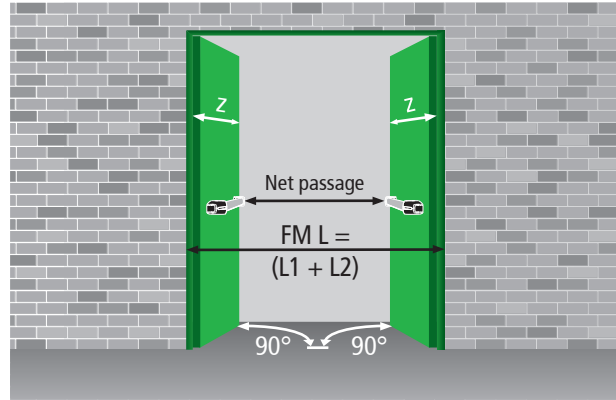
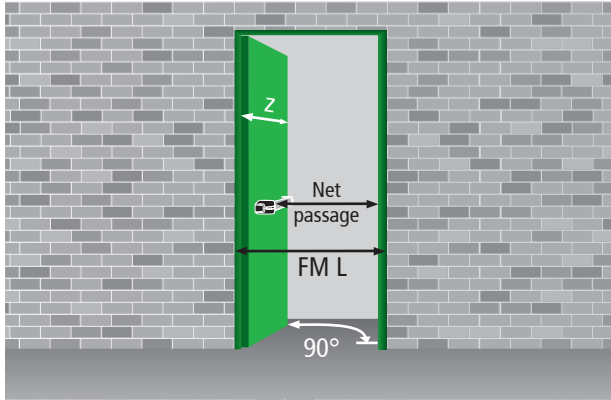

### Net passage calculation

| panic bar type                           | protrusion | one-leaved door | two-leaved door    |
|--|------------|-----------------|--------------------|
| EXUS                                     | 125        | FML - 209       | FML - 344          |
| TWIST                                    | 100        | FML - 184       | FML - 294          |
| SLASH                                    | 75         | FML - 159       | FML - 244          |
| FAST TOUCH                               | 75         | FML - 159       | FML - 244          |
| without panic bar                        | -          | FML - 84        | FML - 94           |
| z = leaf protrusion relative to the wall |            | FML + 11        | L1 + 11<br>L2 + 56 |

## OVERALL DIMENSIONS WITH 180 DEGREE OPENING - HANDLE HEIGHT

### One-leaved door

x = FML - 4  
h handle = FMH/2 + 50

### Two-leaved door

x = L1 - 4    y = L2 + 42  
h handle = FMH/2 + 50

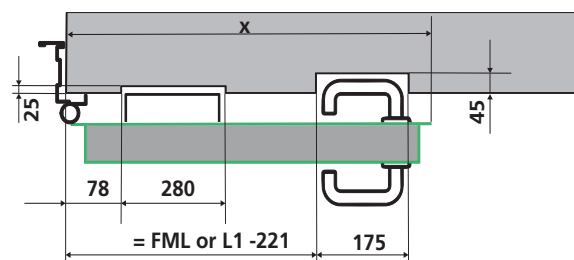
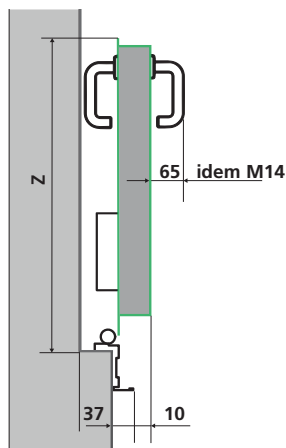
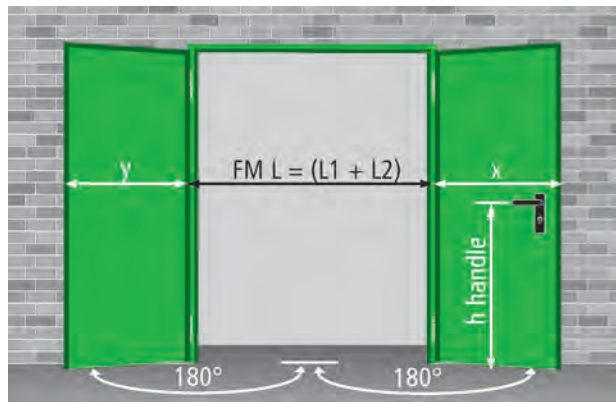

**“the quality multipurpose,  
reversible and heat-insulated”**





## UNIVER NINZ Doors

MULTIPURPOSE VERSION

FEATURES

74 - 77

SPECIFIC OPTIONAL ACCESSORIES

78 - 80

ADDITIONAL PERFORMANCES

81 - 85

INSTALLATION METHODS

86

DOOR CROSS SECTIONS - MEASUREMENTS

87

ORDER MEASUREMENTS

88

OPENING MEASUREMENTS - OVERALL DIMENSIONS

89

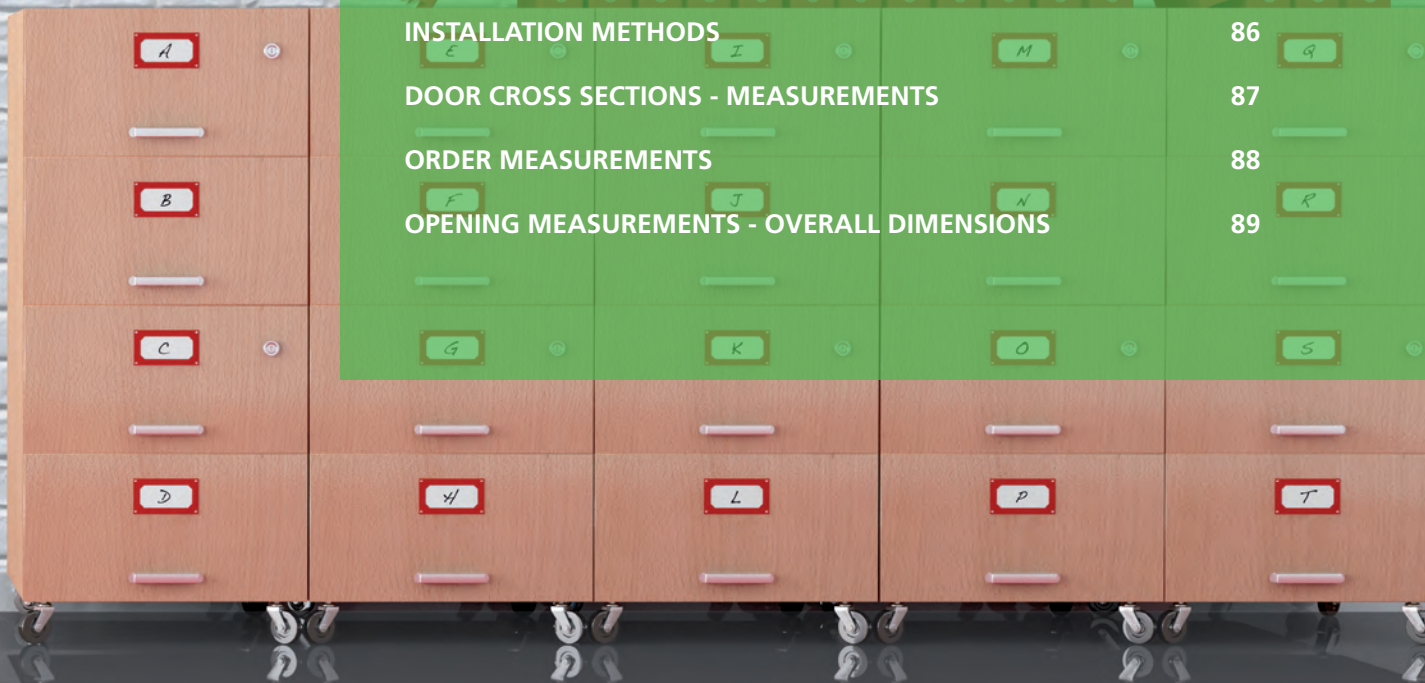

# Features

## UNIVER multipurpose doors



UNIVER  
multipurpose

### THE HIGH QUALITY MULTIPURPOSE

#### “Quality first”

- Solid design and manufacture
- Fully galvanized door, including the “hidden” parts
- Made of “Sendzimir” process hot-galvanized sheet metal
- Corrosion protection also provided along cut edges of the metal sheets
- Painted with epoxy-polyester thermoset powders in a 180 degrees (Celsius) oven
- Substantial paint layer (70 microns plus)
- Optimal corrosion resistance demonstrated by 500 hour salt-fog test
- Unaffected by severe climate changes, demonstrated by 2000 hours with +60° to -10° cycles at 75% humidity
- Finishing with high-quality aesthetics
- Orange skin anti-scratch structured paint
- Customizable with wide selection of RAL colors

#### CE marking for external use

- Wind resistance and water tightness
- Thermal isolation
- Air permeability
- Suitable for use with panic bar

#### “Practicality of use”

- Door reversibility
- Indication of door opening direction not necessary
- Reduction of stock for retailers
- Simplifies choices for end customers
- Easy installation

#### “Versatility”

- Suitable for multiple uses because of its sturdiness
- Vast assortment of accessories
- Customized measurements also available

#### “Manufacturing technology”

- Manufacturing in modern and functional facilities which employ the latest technologies to maintain high quality levels and product uniformity
- The entire production process - from raw materials to painted and packaged products - takes place inside Ninz’s own facilities, ensuring a 360 degree door control



One-leaved doors



Two-leaved doors

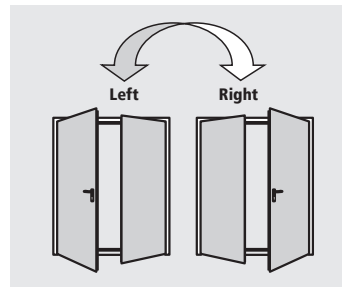
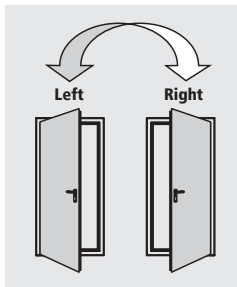

## STANDARD ELEMENTS

### Door leaf

- Made of "Sendzimir" processed hot-galvanized sheet metal, press folded and electro welded
- Perimetral rebate on 4 sides
- Heat-insulated with mineral wool
- Internal stiffeners for overhead door closer and panic bar
- Thickness of 60mm

### Doorframe

- Made of "Sendzimir" processed hot-galvanized sheet metal
- Grooves for rebate sealing
- Suitable for anchors for mortar fixing or expansion screws
- Detachable rebate for application on finished flooring
- Removable threshold for thresholdless installation (except for external doors  $\text{C}\text{€}$  marked)
- Strike plates in black plastic for lock bolt
- Assembled doorframes for one-leaved doors
- Assembly required for two-leaved doorframes

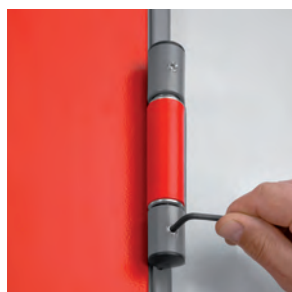

### Hinges

- Nr. 2 three-wing hinges for each leaf
- of which one 1 ball-bearing hinge with screws for vertical adjustment of the leaf,  $\text{C}\text{€}$  marked as per EN 1935, classified for up to 160 kg load, 200.000 cycles durability, suitable for fire door use
- and one hinge with self-closing spring

### Safety bolts

- Nr. 2 safety bolts on hinge side leaf edge

### Locking mechanism

- Reversible locking mechanism with bolt and central latch
- Insert with patent key, Euro profile cylinder ready

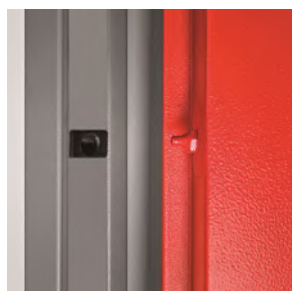

### Handle

- Handle in black plastic with steel core
- Steel installation plate with cylinder hole
- Cover plate in black plastic
- Fastener screws and patent key insert

# Features

UNIVER multipurpose doors

**NINZ**<sup>®</sup>  
FIREDOORS

UNIVER  
multipurpose

## INCLUDED ACCESSORIES

### Safety lock

- "Flush-bolt" automatic locking of the inactive leaf
- Lever control for unlocking

### Upper coupling system for the inactive leaf

- Inactive leaf lock activated device which inserts rod into the upper strike box
- Upper strike box in black plastic with steel roller

### Lower coupling system for the inactive leaf

- Vertical rod with steel point which inserts into lower strike box
- Floor catch (floor-mounted bushing) in black plastic, for doors without threshold
- Floor catch in black plastic with steel roller, for doors with threshold

### Identification plate

- Metal tag with door identification data



Standard paint - group 01: RAL 9010

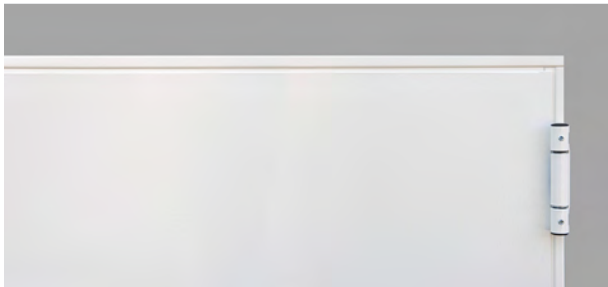

### Finishing

- Standard paint with epoxy-polyester thermoset powders in a 180 degrees oven, orange skin, anti-scratch finishing
- Standard paint RAL 9010

### Standard packaging

- Single door wrapped into stretchable polyethylene (PE) film
- Assembled doorframes for one-leaved doors
- Assembly required for doorframes for two-leaved doors
- Palletized on wooden pallets

### NOTE

If the door ever needs to be repainted, follow the precise instructions on the "Painting" page.

### OPTIONAL ACCESSORIES

A wide variety of accessories and surface finishes are available on request for maximum value enhancement of Univer doors to your own specific needs.

The proper accessories can help resolve:

#### Safety-related needs

- Doors for panic exits (see panic bars)
- Doors for emergency exits (see emergency exit handles)

#### Installation and utilization needs

- Frame extensions
- Drip steel-profile
- Kick and protection plates in stainless steel
- Windows
- Ventilation grills
- Roofing

#### Access-related control issues

- Electrically-activated lock mechanisms MAC
- Electric handle mechanisms
- Magnetic blocking mechanisms

#### Performance enhancing

- Sealing
- Cylinders
- Door closers
- Special handles



#### NOTE

Details about optional accessories may be found in the present brochure in chapters:

- Painting and NDD decorations
- Accessories for metal doors
- Emergency handles and panic bars

#### Customized finishing

- Select finishing from a wide variety of RAL colours
- NDD – Ninz Digital Decor, graphic images applied with special ink jets and protected by a transparent topcoat. Infinite varieties of customizable decorations in harmony with specific door settings
- Stainless steel handles
- Colored handles

#### Packaging for maximum protection

Sturdy wooden crates protect all doors and related accessories

- For NDD decorated doors
- On construction sites
- During shipping abroad
- For special transport

The following optional accessories make Univer doors irreversible, requiring the indication of the door opening direction when the order is placed:

- SLASH panic bar
- Panic bar for inactive leaves
- Window and ventilation grills
- MAC locks
- ELM/cisa and ELM/mt electric handle
- Special locks (Stel 15)
- NDD - Ninz Digital Decor

Right-opening (Right) doors are the default selection if opening direction is not specified.

# Specific optional accessories

## UNIVER multipurpose doors



### MULTIPURPOSE WINDOW WITH METAL WINDOW FRAME

Upon request one- and two-leaved doors may be equipped with round or rectangular windows, with different types of glass and respective window frames fixed with screws. The window frame carters are included for round window and available as an optional accessory for the rectangular one.

#### Production limits

Window sizes are standard and the minimum border strips around the window may not be reduced.

#### Borders, window position

„Border measurement“ refers to the distance from the edge of the window to the wall opening of the door.

#### Elevation for round windows

| window dimensions | FM H           | position     |
|-------------------|----------------|--------------|
| Ø 300             | minimum 1950   | Y=1600       |
| Ø 300             | less than 1950 | Y=FM H - 350 |
| Ø 400             | minimum 2150   | Y=1600       |
| Ø 400             | 1950-2149      | Y=1550       |
| Ø 400             | less than 1950 | Y=FM H - 400 |

#### Elevation of rectangular windows

| window dimensions L x H | FM H           | position     |
|-------------------------|----------------|--------------|
| 250/300 x 400           | minimum 2150   | Z=1450       |
| 250/300 x 400           | 1950-2149      | Z=1350       |
| 250/300 x 400           | less than 1950 | Z=FM H - 600 |

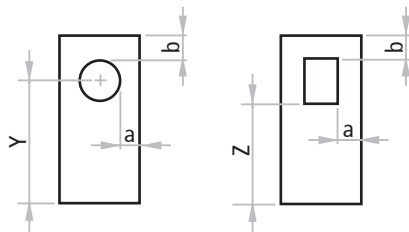

| Window dimensions | min. border            | dimensions FM L min. |     |                                    |
|-------------------|------------------------|----------------------|-----|------------------------------------|
|                   |                        | a                    | b   |                                    |
| -                 | Ø 300<br>Ø 400         | 200                  | 200 | 700<br>800                         |
| -                 | Ø 300<br>Ø 400         | 200                  | 200 | L1 700 + L2 400<br>L1 800 + L2 400 |
| -                 | Ø 300<br>Ø 400         | 200                  | 200 | L1 700 + L2 700<br>L1 800 + L2 800 |
| -                 | 250 x 400<br>300 x 400 | 200                  | 200 | 650<br>700                         |
| -                 | 250 x 400<br>300 x 400 | 200                  | 200 | L1 650 + L2 400<br>L1 700 + L2 400 |
| -                 | 250 x 400<br>300 x 400 | 200                  | 200 | L1 650 + L2 650<br>L1 700 + L2 700 |



#### NOTE

For the rectangular windows the frame carters are an optional accessory

#### Glasses available

| laminated, 2B2 rated   | 3 + 3 mm          | shapes                |
|--|-------------------|-----------------------|
|  |                   | rectangular, circular |
| laminated, 2B2 rated   | 4 + 4 mm          | rectangular           |
| low emission double glass window with 2 laminated glazings 2B2 rated | 3+3 / 12 / 3+3 mm | rectangular           |

#### Round window cross section

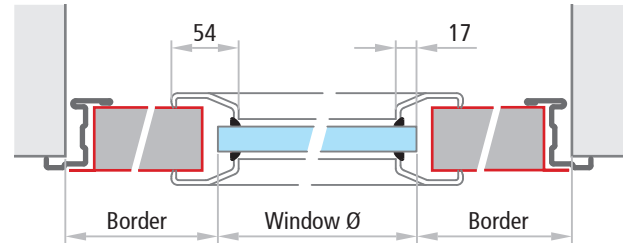

#### Rectangular window cross section

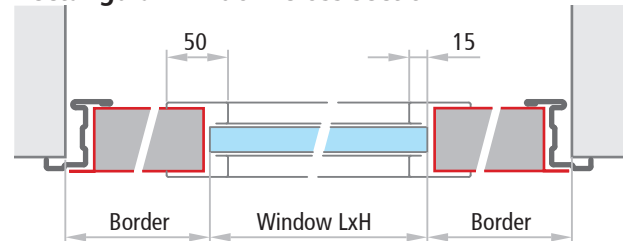

#### NOTE

The positions indicated above are those standard. Different positions may be considered as long as they respect the minimum „a“ and „b“ border strips. The window itself may not be supplied separately except for replacements. It is always advisable to equip doors with windows with a closing regulator.

# Specific optional accessories

UNIVER multipurpose doors



UNIVER multipurpose

## MULTIPURPOSE WINDOW WITH RUBBER WINDOW FRAME

On request, one- and two-leaved doors may be equipped with round or rectangular windows, with laminated 3+3mm glass, 2B2 rated, framed with a black rubber EPDM profile.

The corners of rectangular windows are rounded (radius of approx. 100mm).

### Production limits

Window sizes are standard and the minimum window border strip measurements may not be reduced.

### Borders, window position

"Border measurement" refers to the distance from the edge of the window to the wall opening of the door.



### Elevation of round windows

| window dimensions | FM H           | position     |
|-------------------|----------------|--------------|
| Ø 300             | minimum 1950   | Y=1600       |
| Ø 300             | less than 1950 | Y=FM H - 350 |
| Ø 400             | minimum 2000   | Y=1600       |
| Ø 400             | less than 2000 | Y=FM H - 400 |

### Elevation of rectangular windows

| window dimensions L x H | FM H           | position     |
|-------------------------|----------------|--------------|
| 300 x 500               | minimum 1950   | Z=1500       |
| 300 x 500               | less than 1950 | Z=FM H - 450 |
| 400 x 700               | minimum 2050   | Z=1500       |
| 400 x 700               | less than 2050 | Z=FM H - 550 |

### Round and rectangular window cross sections

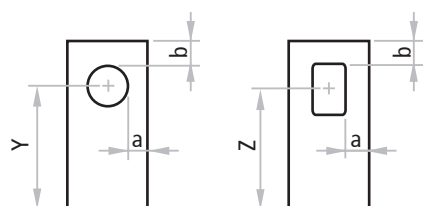
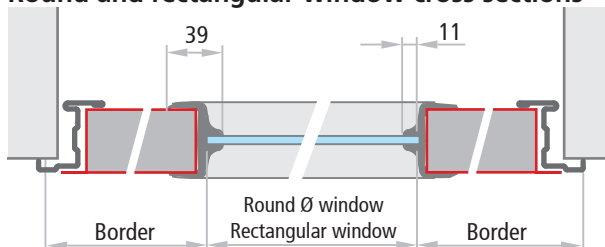

### NOTE

The positions indicated above are those standard. Different positions may be considered as long as they respect the minimum "a" and "b" borders. It is always advisable for doors with windows to be equipped with door closers for controlled closing.

### Window dimensions

| Window dimensions | minimum border         |            | FM L min. dimensions               |
|-------------------|------------------------|------------|------------------------------------|
|                   | a                      | b          |                                    |
| -                 | Ø 300<br>Ø 400         | 200<br>200 | 700<br>800                         |
| -                 | Ø 300<br>Ø 400         | 200<br>200 | L1 700 + L2 400<br>L1 800 + L2 400 |
| -                 | Ø 300<br>Ø 400         | 200<br>200 | L1 700 + L2 700<br>L1 800 + L2 800 |
| -                 | 300 x 500<br>400 x 700 | 200<br>200 | 700<br>800                         |
| -                 | 300 x 500<br>400 x 700 | 200<br>200 | L1 700 + L2 400<br>L1 800 + L2 400 |
| -                 | 300 x 500<br>400 x 700 | 200<br>200 | L1 700 + L2 700<br>L1 800 + L2 800 |

# Specific optional accessories

UNIVER multipurpose doors



UNIVER  
multipurpose

## FRAME EXTENSIONS FOR UNIVER DOORS

### IM 12

Frame extension to be mounted in addition to the Univer frame acting as wall cladding. Made of „Sendzimir“ processed hot-galvanized sheet metal and painted the same color as the doorframe with epoxy-polyester powders. Profile on three sides, upper corners with 90 degree joint, fixing with screws and plugs (screws and plugs not included).

IM 12: for installation on 80mm (min.) wall thickness

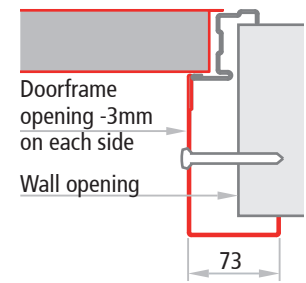
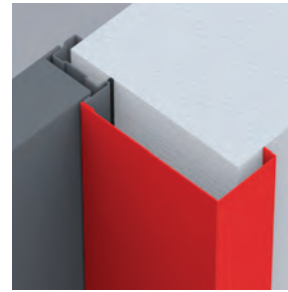

Frame extension IM 12

### IM 14

Telescopic frame extension to be screwed to the Univer doorframe acting as wall cladding. Consists of two overlapping profiles with a 25mm adjustable range. Made of „Sendzimir“ processed hot-galvanized sheet metal painted the same color as the doorframe with epoxy-polyester powders. Profile on three sides, upper corners with 90 degree joint.

Complete with fastener screws. To mount the frame extension, fixing holes need to be drilled into doorframe on site. Combine with sealing to conceal the screw heads.

IM 14: for installation on 135mm (min.) wall thickness

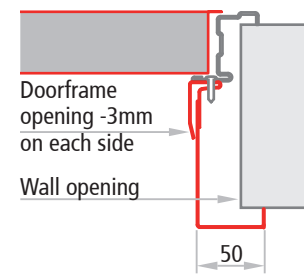
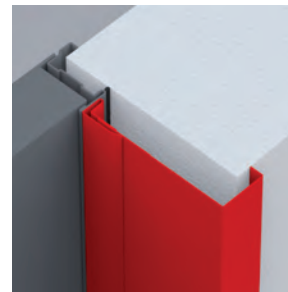

Frame extension IM 14

## VENTILATION LOUVER

Ventilation louver made of either black or white PVC, 482x99mm (air passage approx. 150cm<sup>2</sup>). The opening direction of the door needs to be specified.



Minimum FML = 650mm



## REBATE SEALING CR

Rebate sealing in black extruded profile to cut and to be pressed into the dedicated groove of the perimetral frame.

Sealing in black extruded profile self-adhesive to cut for application to the central joint of two-leaved doors.

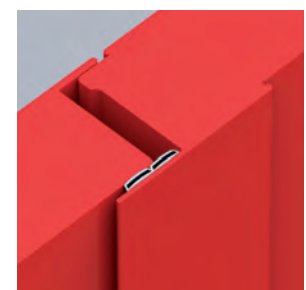

# Additional performances

UNIVER multipurpose doors



UNIVER multipurpose

## INTERNAL PEDESTRIAN DOORS



Pedestrian interior doors are not yet subject to CE marking as the relevant standard EN 14351-2 has not yet been harmonized. The performances listed in the standard can however be used as a reference for classifying the door for indoor uses, such as:

- air permeability according to EN 1026:2001
- thermal transmittance according to EN ISO 10077-1:2018 e EN ISO 10077-2:2018





### ATTENTION

For the dimensional limits, minimum border measurements or production possibilities please refer to the specific pages of this brochure.

The values for the thermal transmittance  $W/m^2K$  shown in the table on the next page are given by the calculation according to the norm EN ISO 10077-1 done on samples of the dimensions 1,23x2,18 for areas  $\leq 3,6m^2$  and on samples of the dimensions 2,00x2,18 for areas  $> 3,6m^2$ .

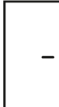
All performance values indicated in the table are valid only in presence of the following accessories or enhancements:

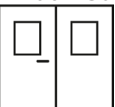
- Combo Thermo/CB (with lower threshold)
  - frame on all 4 sides
  - if the door is installed on an escape route, it is necessary to fill the difference in height on the push side between the floor and the lower threshold with cement mortar or polyurethane foam
  - isolation of the door frame with the filling of cement mortar or polyurethane foam
  - installation of rubber seals along the entire perimeter of the door frame including the central rebate for double leaved doors
  - sealing of the perimeter of the frame (push side) with neutral silicone
- Combo Thermo/SB (without lower threshold)
  - isolation of the door frame with the filling of cement mortar or polyurethane foam
  - installation of rubber seals along the 3 sides of the frame including the central rebate for two-leaved doors

| UNIVER multipurpose doors   |                       | DIMENSION<br>FM L X H | Combo Thermo/CB<br>with lower threshold<br>and gasket on all 4 sides | Combo thermo/SB<br>without lower threshold<br>and gasket on 3 sides |               |
|---|-----------------------|-----------------------|--|---|---------------|
| Test report CPR/35/07/2019  |                       |                       |  |   |               |
| Without windows<br>  | UNI EN 1026:2001      | $\leq 3,6 m^2$        |  |   |               |
|   | Air permeability      |                       | Classe 2   | N.P.D.  |               |
|   | UNI EN 10077-1-2:2018 |                       |  |   |               |
|   | Thermal transmittance |                       | 1,60 $W/m^2K$  | 1,60 $W/m^2K$   |               |
| With windows 300x400<br>   | UNI EN 1026:2001      | $\leq 3,6 m^2$        |  |   |               |
|   | Air permeability      |                       | Classe2  | N.P.D.  |               |
|   | UNI EN 10077-1-2:2018 |                       |  |   |               |
|   | Thermal transmittance |                       | 1,90 $W/m^2K$  | 1,90 $W/m^2K$   |               |
| Without windows<br>  | UNI EN 1026:2001      | $\leq 3,6 m^2$        |  |   |               |
|   | Air permeability      |                       | Classe3  | N.P.D.  |               |
|   | UNI EN 10077-1-2:2018 |                       |  |   |               |
|   |                       | Thermal transmittance |  | 2,00 $W/m^2K$   | 2,00 $W/m^2K$ |
|   | UNI EN 1026:2001      | $> 3,6 m^2$           |  |   |               |
|   | Air permeability      |                       | Classe 3   | N.P.D.  |               |
| UNI EN 10077-1-2:2018   |                       |                       |  |   |               |
|   | Thermal transmittance |                       | 1,60 $W/m^2K$  | 1,60 $W/m^2K$   |               |
| With window 300x400<br><br> | UNI EN 1026:2001      | $\leq 3,6 m^2$        |  |   |               |
|   | Air permeability      |                       | Classe 3   | N.P.D.  |               |
|   | UNI EN 10077-1-2:2018 |                       |  |   |               |
|   |                       | Thermal transmittance |  | 2,40 $W/m^2K$   | 2,40 $W/m^2K$ |
|   | UNI EN 1026:2001      | $> 3,6 m^2$           |  |   |               |
|   | Air permeability      |                       | Classe 3   | N.P.D.  |               |
| UNI EN 10077-1-2:2018   |                       |                       |  |   |               |
|   | Thermal transmittance |                       | 2,10 $W/m^2K$  | 2,10 $W/m^2K$   |               |

# Additional performances

## UNIVER multipurpose doors



UNIVER  
multipurpose

### INTERNAL PEDESTRIAN DOORS

Test report IFT N° 16-000122-PR03



### SMOKE CONTROL

This is the ability of a door set to reduce or eliminate the passage of smoke from one side of the door to the other. Two levels of smoke performance are defined.

Smoke control Sa: when the maximum dispersion value measured at room temperature and at a pressure of 25 Pascal is not greater than 3 m<sup>3</sup>/h per metre through the gap between the door leaf and the door frame excluding eventual losses through the floor threshold.

Smoke control S200: when the maximum dispersion value, measured at room temperature and 200 C and up to a pressure of 50 Pascal, is not greater than 20 m<sup>3</sup>/h for a single door or 30 m<sup>3</sup>/h for a two-door door.

The smoke tightness is verified with a specific technical test in accordance with UNI EN 1634-3, while the classification is provided by UNI EN 13501-2 according to the following criteria:

Sa considers only the seal at room temperature  
S200 considers the seal at room temperature and at 200 C

The price list lists the Combos which add these additional performances to the door.

### ATTENTION

The smoke control performance is only valid in presence of the following accessories or enhancements:

- no fixed threshold
- filling of the slot between frame and wall with cement mortar
- installation of rubber seals along the entire perimeter of the door frame including the central rebate for double leaved doors
- presence of the automatic door sweep
- closing regulator RC/STD for the correct closure of double leaved doors



**Nachweis**  
Rauchdichtheit und selbstschließende  
Eigenschaft von Bauteilen

**ift**  
ROSENHEIM

Klassifizierungsbericht  
Nr.: 21-000932-PR02  
(KB-C05-01-de-01)

NINZ s.p.a.  
Auftraggeber  
Corso Trento 2/A  
38061 ALA  
(Italien)

ift Rosenheim GmbH  
Erstellt durch die  
notifizierte Stelle  
Theodor-Gießl-Straße 7-9  
83026 Rosenheim  
(Deutschland)

Nr.: 0757  
Nummer der  
notifizierten Stelle

Bezeichnung  
"UNIVER Multi EI; 30 / EI; 60 / EW 60 / REI 60 / EI; 90 /  
REI 120"  
(nach den Angaben des Auftraggebers)

Klassifizierung  
Klassifizierung zum Rauchdichtheit und selbstschließende  
Eigenschaft  
nach EN 13501-2:2007+A1:2009 / EN 13501-2:2016

Ausgabennummer 1

Rauchschutzabschluss

**Klassifizierung**  
S<sub>a</sub> / S<sub>200</sub> C5

ift Rosenheim  
13.01.2022

Dr. Gerhard Wackerbauer, Dipl. Phys.  
Leitung Technische Bewertung  
Zertifizierungs- & Überwachungsstelle

Christine Schmaus, Dipl.-Ing. (FH)  
Projektingenieur  
Zertifizierungs- & Überwachungsstelle

Grundlagen  
EN 13501-2:2007+A1:2009  
EN 13501-2:2016  
EN 1634-3:2004/AC:2006  
EN 1191:2017  
EN 16034:2014

Verwendungshinweise  
Dieser Klassifizierungsbericht  
definiert die Klassifizierung, die  
dem Bauteil gemäß Produkt-  
name in Übereinstimmung mit  
dem Verfahren nach  
EN 13501-2 zugeordnet wird.  
Dieses Dokument stellt keine  
Typengenehmigung oder Zerti-  
fizierung dar.  
Gültigkeit  
Der Nachweis ermöglicht keine  
Aussage über weitere lei-  
stungs- und qualitätsbestim-  
menden Eigenschaften des Pro-  
dukts.  
Vorfachrichtungenhinweise  
Es gilt das ift-Merkblatt „Bedin-  
gungen und Hinweise zur Be-  
nutzung von ift-Nachweisen“.

Inhalt  
Dieser Klassifizierungsbericht  
besteht aus 13 Seiten und darf  
nicht auszugsweise benutzt  
oder auszugsweise reprodu-  
ziert werden:  
1. Einleitung  
2. Details zum klassifizierten  
Produkt  
3. Prüfberichte/Beichte zum  
erweiterten Anwendungsbere-  
ich und Prüfergebnisse  
zum Nachweis der Klassi-  
fizierung  
4. Klassifizierung und Anwen-  
dungsbereich  
5. Einschränkungen

ift Rosenheim GmbH  
Kontakt  
Tel. +49 89 201 281-0  
Fax +49 89 201 281-200  
www.ift-rosenheim.de

Prüfung und Zertifizierung - ift ROSENHEIM 11025  
Institution - EN ISO/IEC 17025  
Zertifizierung - ift ROSENHEIM 11025  
Zertifizierung - ift ROSENHEIM 11025

notifiziert durch ift  
DAKKS  
Zertifizierungsstelle

# Additional performances

UNIVER multipurpose doors



## EXTERNAL PEDESTRIAN DOORS

Certificato CE 1404 - CPR -3736  
EN 16034:2014 e EN 14351-1:2006+A2:2016



According to standards EN 16034 and EN 14351-1, an external door is defined as a door that separates the internal climate from the external environment of a building. For this application, doors must be CE marked in accordance with EN 16034:2014 and EN 14351-1:2006+A2:2016. Furthermore, if the door is installed along an escape route and equipped with a panic or emergency exit device, it is also subject to the assessment and verification of constancy of performance under "System 1". This requires the manufacturer to hold a Certificate of Constancy of Performance issued by a Notified Body — for NINZ S.p.A., this is certificate 1404 - CPR - 3736.

Univer for external use must be ordered with the specific CE Combo Est options available in the Univer multipurpose price list, selected based on the essential requirements indicated in the tables on the following pages, and considering those that are mandatory according to the applicable national regulations. This ensures that each door is provided with the required CE marking and the documentation specified by the current legislation.

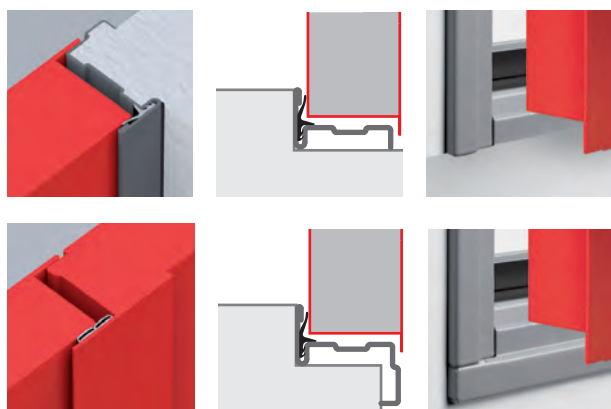

| Essential requirements*  | EN 16034 | EN 14351 |
|--|----------|----------|
| Fire resistance  | YES      | NO       |
| Smoke control  | YES      | NO       |
| Self - closing   | YES      | NO       |
| Durability of performance  | YES      | NO       |
| Thermal insulation   | NO       | YES      |
| Air permeability   | NO       | YES      |
| Water tightness  | NO       | NO       |
| Acoustic performance   | NO       | NO       |
| Wind resistance  | NO       | NO       |
| Load-bearing capacity of safety devices  | NO       | YES      |
| Release/unlocking capability<br>(mandatory for doors installed on escape routes) | NO       | YES      |
| Minimum clear passage height: 2000 mm  | NO       | YES      |

\* Required under binding national provisions

### ATTENTION

For dimensional limits, minimum edge requirements and production options, please refer to the specific pages of this catalogue. The thermal transmittance values (W/m<sup>2</sup>K) shown in the tables on the following pages are calculated in accordance with EN ISO 10077-1, applied to samples measuring 1.23 x 2.18 m for areas ≤ 3.6 m<sup>2</sup> and to samples measuring 2.00 x 2.18 m for areas > 3.6 m<sup>2</sup>. All performance values listed in the table are valid only if the door is installed with the following accessories and measures:

- presence of a bottom rebate threshold
- in case of installation along an escape route, the floor on the push side must be raised to fully level the gap between the floor and the bottom threshold
- frame insulation by filling with polyurethane foam or cement-based mortar
- application of sealing gaskets along the entire perimeter of the frame and on the central mullion in double-leaf doors
- sealing of the frame's perimeter edge (on the push side) with neutral silicone
- for doors with vision panels: installation of external fire-resistant glazing sized 300x400 mm

### NOTES

For information regarding outdoor installation, please refer to the "Warnings" section on the last page of this catalogue.



ZAVOD ZA  
GRADNENIŠTVO  
SLOVENIJE  
  
SLOVENIAN  
NATIONAL BUILDING  
AND CIVIL ENGINEERING  
INSTITUTE  
Domenova ulica 12  
1000 Ljubljana  
Slovenija  
info@zag.si  
www.zag.si  
  
Notified certification body  
NB 1404

### Certificate of constancy of performance

1404 – CPR – 3736

In compliance with Regulation (EU) No 305/2011 of the European Parliament and of the Council of 9 March 2011 (the Construction products Regulation or CPR), this certificate applies to the construction product

**Single and double leaf door UNIVER MULTI**  
(doors that fall within the scope of standard EN 14351-1:2006+A2:2016)

placed on the market under the name or trade mark of  
**NINZ S.p.A.,**  
Corso Trento 2, 38061 Ala (TN), Italy  
  
and produced in the manufacturing plant  
**NINZ S.p.A.,**  
Corso Trento 2, 38061 Ala (TN), Italy.

This certificate attests that all provisions concerning the assessment and verification of constancy of performance described in Annex ZA of the standards

**EN 16034:2014 and EN 14351-1:2006+A2:2016**

under system 1 for the performance set out in this certificate are applied and that the factory production control conducted by the manufacturer is assessed to ensure the

**constancy of performance of the construction product.**

This certificate was first issued on 4. 6. 2024 and will remain valid until 4. 6. 2029 as long as neither the harmonised standards, the construction products, the AVCP method nor the manufacturing conditions in the plant are modified significantly, unless suspended or withdrawn by the notified product certification body.

Detailed information about the scope of the product is given in the annex to this certificate.

Ljubljana, 4. 6. 2024

Authorised signatory of the Certification body:  
mag. Egon Mitost, univ. dipl. inž. grad.

ZAG-001-206-0v1

This certificate has a total of 2 pages



Certificate No. 1404 – CPR – 3736, page 1

# Additional performances

UNIVER multipurpose doors



UNIVER  
multipurpose



| UNIVER multipurpose<br><br>Certificate CE:<br>1404 - CPR -3736 |   | Angular frame | Combo with bottom rebate, CR compression seal on all 4 sides and door closer for C5 version |                         | Combo with CR compression seal on 3 sides, drop-down seal and door closer for C5 version |                                 |
|---|---|---------------|---|-------------------------|--|---------------------------------|
|   |   |               | CE  | CE C5                   | CE S200/GS<br>CE S 200/GSV   | CE S200/GS C5<br>CE S200/GSV C5 |
| <b>Without window</b><br><br>                                 | <b>EN 16034:2014</b>                    |               |   |                         |  |                                 |
|   | Fire resistance                         | ✓             | N.P.D.  | N.P.D.                  | N.P.D.   | N.P.D.                          |
|   | Smoke control                           | ✓             | N.P.D.  | N.P.D.                  | Sa / S200  | Sa / S200                       |
|   | Ability to release / lock               | ✓             | N.P.D.  | N.P.D.                  | N.P.D.   | N.P.D.                          |
|   | Self-closing                            | ✓             | C   | C                       | C  | C                               |
|   | Durability of release mechanism         | ✓             | N.P.D.  | N.P.D.                  | N.P.D.   | N.P.D.                          |
|   | Durability of self-closing              |               |   |                         |  |                                 |
|   | - against degradation                   | ✓             | 0   | 5                       | 0  | 5                               |
|   | - against corrosion                     | ✓             | N.P.D.  | N.P.D.                  | N.P.D.   | N.P.D.                          |
|   | <b>EN 14351-1:2006+A2:2016</b>          |               |   |                         |  |                                 |
|   | Air permeability                        | ✓             | 2   | 2                       | 2  | 2                               |
|   | Water tightness                         | ✓             | 2A  | 2A                      | N.P.D.   | N.P.D.                          |
|   | Wind load resistance                    |               |   |                         |  |                                 |
|   | - door with FM ≤ 900x2150               | ✓             | C2  | C2                      | N.P.D.   | N.P.D.                          |
|   | - door with FM > 900x2150               | ✓             | N.P.D.  | N.P.D.                  | N.P.D.   | N.P.D.                          |
|   | Impact resistance                       | ✓             | N.P.D.  | N.P.D.                  | N.P.D.   | N.P.D.                          |
|   | Load-bearing capacity of safety devices | ✓             | Exceeds   | Exceeds                 | Exceeds  | Exceeds                         |
|   | Acoustic performance                    | ✓             | N.P.D.  | N.P.D.                  | N.P.D.   | N.P.D.                          |
|   | Thermal transmittance                   | ✓             | 1,60 W/m <sup>2</sup> K   | 1,60 W/m <sup>2</sup> K | N.P.D.   | N.P.D.                          |
|   | Ability to release / open               | ✓             | N.P.D.  | N.P.D.                  | N.P.D.   | N.P.D.                          |
| <b>With window 300x400</b><br><br>                           | <b>EN 16034:2014</b>                    |               |   |                         |  |                                 |
|   | Fire resistance                         | ✓             | N.P.D.  | N.P.D.                  | N.P.D.   | N.P.D.                          |
|   | Smoke control                           | ✓             | N.P.D.  | N.P.D.                  | Sa / S200  | Sa / S200                       |
|   | Ability to release / lock               | ✓             | N.P.D.  | N.P.D.                  | N.P.D.   | N.P.D.                          |
|   | Self-closing                            | ✓             |   |                         |  |                                 |
|   | Durability of release mechanism         | ✓             | N.P.D.  | N.P.D.                  | N.P.D.   | N.P.D.                          |
|   | Durability of self-closing              |               |   |                         |  |                                 |
|   | - against degradation                   | ✓             | 0   | 5                       | 0  | 5                               |
|   | - against corrosion                     | ✓             | N.P.D.  | N.P.D.                  | N.P.D.   | N.P.D.                          |
|   | <b>EN 14351-1:2006+A2:2016</b>          |               |   |                         |  |                                 |
|   | Air permeability                        | ✓             | 2   | 2                       | 2  | 2                               |
|   | Water tightness                         | ✓             | 2A  | 2A                      | N.P.D.   | N.P.D.                          |
|   | Wind load resistance                    |               |   |                         |  |                                 |
|   | - door with FM ≤ 900x2150               | ✓             | C2  | C2                      | N.P.D.   | N.P.D.                          |
|   | - door with FM > 900x2150               | ✓             | N.P.D.  | N.P.D.                  | N.P.D.   | N.P.D.                          |
|   | Impact resistance                       | ✓             | N.P.D.  | N.P.D.                  | N.P.D.   | N.P.D.                          |
|   | Load-bearing capacity of safety devices | ✓             | Exceeds   | Exceeds                 | Exceeds  | Exceeds                         |
|   | Acoustic performance                    | ✓             | N.P.D.  | N.P.D.                  | N.P.D.   | N.P.D.                          |
|   | Thermal transmittance                   | ✓             | 1,90 W/m <sup>2</sup> K   | 1,90 W/m <sup>2</sup> K | N.P.D.   | N.P.D.                          |
|   | Ability to release / open               | ✓             | N.P.D.  | N.P.D.                  | N.P.D.   | N.P.D.                          |

# Additional performances

UNIVER multipurpose doors

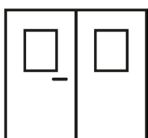
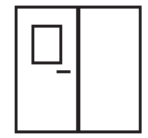

UNIVER multipurpose

| UNIVER multipurpose<br><br>Certificate CE:<br>1404 - CPR - 3736   |   | Angular frame | Combo with bottom rebate, CR compression seal on all 4 sides and door closer for C5 version |                         | Combo with CR compression seal on 3 sides, drop-down seal and door closer for C5 version |                                 |
|--|---|---------------|---|-------------------------|--|---------------------------------|
|  |   |               | CE  | CE C5                   | CE S200/GS<br>CE S 200/GSV   | CE S200/GS C5<br>CE S200/GSV C5 |
| <b>Without window</b><br><br>  | <b>EN 16034:2014</b>                          |               |   |                         |  |                                 |
|  | Fire resistance                               | ✓             | N.P.D.  | N.P.D.                  | N.P.D.   | N.P.D.                          |
|  | Smoke control                                 | ✓             | N.P.D.  | N.P.D.                  | Sa / S200  | Sa / S200                       |
|  | Ability to release / lock                     | ✓             | N.P.D.  | N.P.D.                  | N.P.D.   | N.P.D.                          |
|  | Self-closing                                  | ✓             | C   | C                       | C  | C                               |
|  | Durability of release mechanism               | ✓             | N.P.D.  | N.P.D.                  | N.P.D.   | N.P.D.                          |
|  | Durability of self-closing                    |               |   |                         |  |                                 |
|  | - against degradation                         | ✓             | 0   | 5                       | 0  | 5                               |
|  | - against corrosion                           | ✓             | N.P.D.  | N.P.D.                  | N.P.D.   | N.P.D.                          |
|  | <b>EN 14351-1:2006+A2:2016</b>                |               |   |                         |  |                                 |
|  | Air permeability                              | ✓             | 3   | 3                       | 3  | 3                               |
|  | Water tightness                               | ✓             | 3A - 9B   | 3A - 9B                 | N.P.D.   | N.P.D.                          |
|  | Wind load resistance                          |               |   |                         |  |                                 |
|  | - doow with FM ≤ 2000x2150                    | ✓             | C2  | C2                      | N.P.D.   | N.P.D.                          |
|  | - door with FM > 2000x2150                    | ✓             | N.P.D.  | N.P.D.                  | N.P.D.   | N.P.D.                          |
|  | Impact resistance                             | ✓             | N.P.D.  | N.P.D.                  | N.P.D.   | N.P.D.                          |
|  | Load-bearing capacity of safety devices       | ✓             | Exceeds   | Exceeds                 | Exceeds  | Exceeds                         |
|  | Acoustic performance                          | ✓             | N.P.D.  | N.P.D.                  | N.P.D.   | N.P.D.                          |
|  | Thermal transmittance FM ≤ 3,6 m <sup>2</sup> | ✓             | 2,00 W/m <sup>2</sup> K   | 2,00 W/m <sup>2</sup> K | N.P.D.   | N.P.D.                          |
|  | Thermal transmittance FM > 3,6 m <sup>2</sup> | ✓             | 1,60 W/m <sup>2</sup> K   | 1,60 W/m <sup>2</sup> K | N.P.D.   | N.P.D.                          |
| Ability to release / open  | ✓   | N.P.D.        | N.P.D.  | N.P.D.                  | N.P.D.   |                                 |
| <b>With window 300x400</b><br><br><br><br> | <b>EN 16034:2014</b>                          |               |   |                         |  |                                 |
|  | Fire resistance                               | ✓             | N.P.D.  | N.P.D.                  | N.P.D.   | N.P.D.                          |
|  | Smoke control                                 | ✓             | N.P.D.  | N.P.D.                  | Sa / S200  | Sa / S200                       |
|  | Ability to release / lock                     | ✓             | N.P.D.  | N.P.D.                  | N.P.D.   | N.P.D.                          |
|  | Self-closing                                  | ✓             | C   | C                       | C  | C                               |
|  | Durability of release mechanism               | ✓             | N.P.D.  | N.P.D.                  | N.P.D.   | N.P.D.                          |
|  | Durability of self-closing                    |               |   |                         |  |                                 |
|  | - against degradation                         | ✓             | 0   | 5                       | 0  | 5                               |
|  | - against corrosion                           | ✓             | N.P.D.  | N.P.D.                  | N.P.D.   | N.P.D.                          |
|  | <b>EN 14351-1:2006+A2:2016</b>                |               |   |                         |  |                                 |
|  | Air permeability                              | ✓             | 3   | 3                       | 3  | 3                               |
|  | Water tightness                               | ✓             | 3A - 9B   | 3A - 9B                 | N.P.D.   | N.P.D.                          |
|  | Wind load resistance                          |               |   |                         |  |                                 |
|  | - doow with FM ≤ 2000x2150                    | ✓             | C2  | C2                      | N.P.D.   | N.P.D.                          |
|  | - door with FM > 2000x2150                    | ✓             | N.P.D.  | N.P.D.                  | N.P.D.   | N.P.D.                          |
|  | Impact resistance                             | ✓             | N.P.D.  | N.P.D.                  | N.P.D.   | N.P.D.                          |
|  | Load-bearing capacity of safety devices       | ✓             | Exceeds   | Exceeds                 | Exceeds  | Exceeds                         |
|  | Acoustic performance                          | ✓             | N.P.D.  | N.P.D.                  | N.P.D.   | N.P.D.                          |
|  | Thermal transmittance FM ≤ 3,6 m <sup>2</sup> | ✓             | 2,40 W/m <sup>2</sup> K   | 2,40 W/m <sup>2</sup> K | N.P.D.   | N.P.D.                          |
|  | Thermal transmittance FM > 3,6 m <sup>2</sup> | ✓             | 2,10 W/m <sup>2</sup> K   | 2,10 W/m <sup>2</sup> K | N.P.D.   | N.P.D.                          |
| Ability to release / open  | ✓   | N.P.D.        | N.P.D.  | N.P.D.                  | N.P.D.   |                                 |

# Installation methods

UNIVER multipurpose doors



UNIVER  
multipurpose

## INSTALLATION WITH ANCHORS FOR MORTAR FIXING



For mortar fixing, appropriate cuts will need to be created in the walls (section 80 x 200 mm) or the anchors should be fixed with expansion screws. The anchors should be bent and blocked inside the wall. For a perfect mechanical fit, the space between the doorframe and the masonry shall always be filled with concrete mortar or polyurethane foam; the filling with polyurethane foam is mandatory in case of external use with  $\text{C}\text{E}$  marking or in case of doors with smoke control.

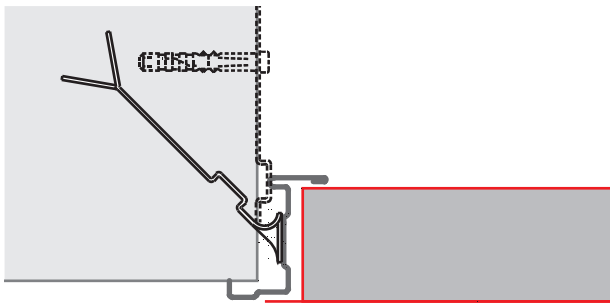

## INSTALLATION FOR EXPANSION SCREWS FIXING

For the installation with expansion screws, the anchors serve as spacers and should not be bent. Using Würth type art. 0910436112 plugs or similar (supplied at the customer's expense), installation is done with expansion screws into the pre-drilled holes present on the frame. For a perfect mechanical fit, the space between the doorframe and the masonry shall always be filled with concrete mortar or polyurethane foam; the filling with polyurethane foam is mandatory in case of external use with  $\text{C}\text{E}$  marking.

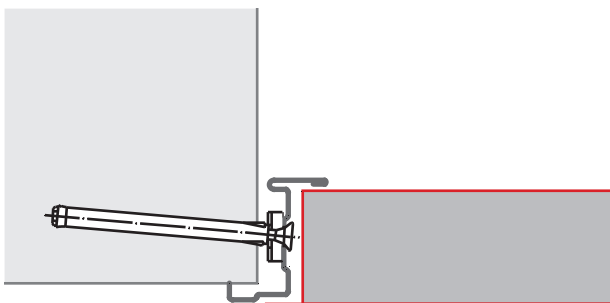

## ANCHOR POSITIONING

### One-leaved doors

Right opening

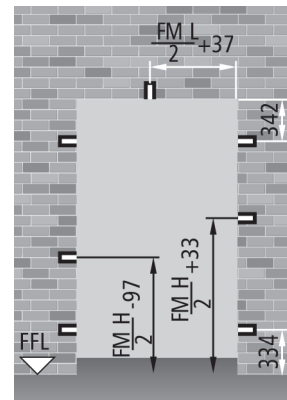

Left opening

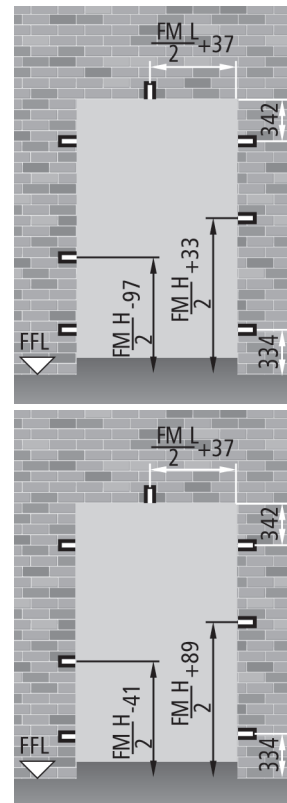

### Two-leaved doors

Right opening

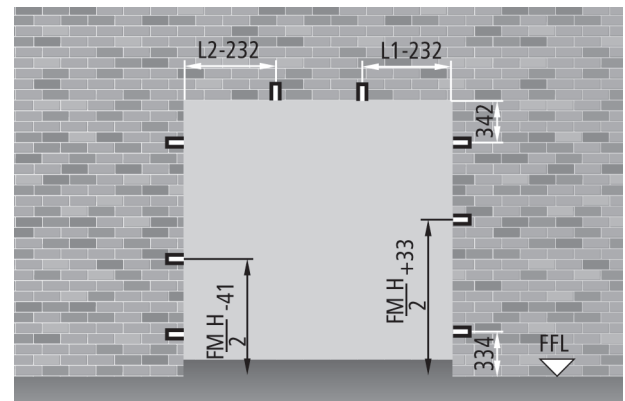

Left opening

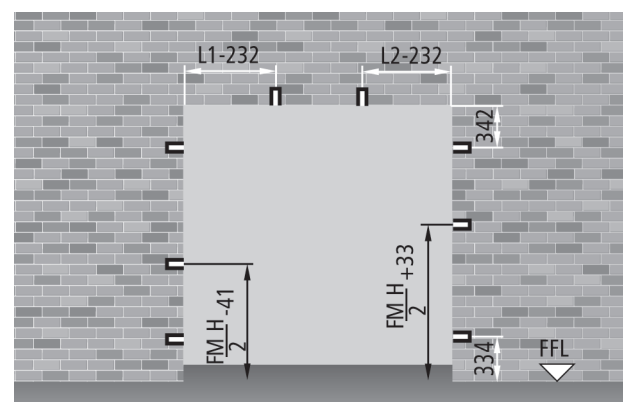

# Door cross sections - Measurements

UNIVER multipurpose doors



UNIVER multipurpose

## One-leaved doors

Horizontal cross section

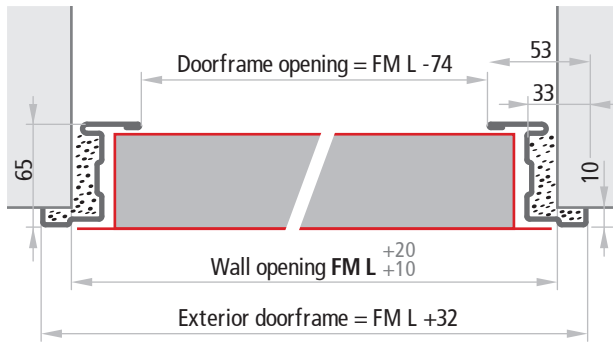

## Doors without lower threshold

Vertical cross section

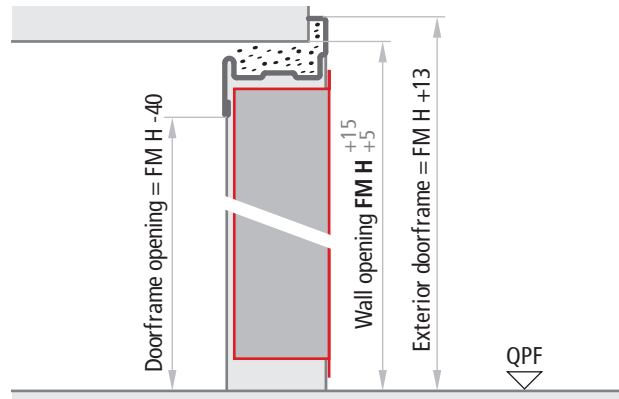

## Doors with internal and external lower threshold

Vertical cross section

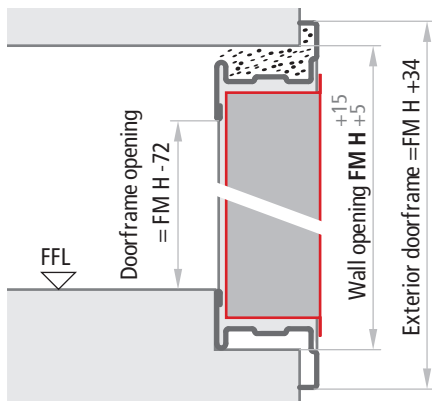

## Doors with internal lower threshold

Vertical cross section

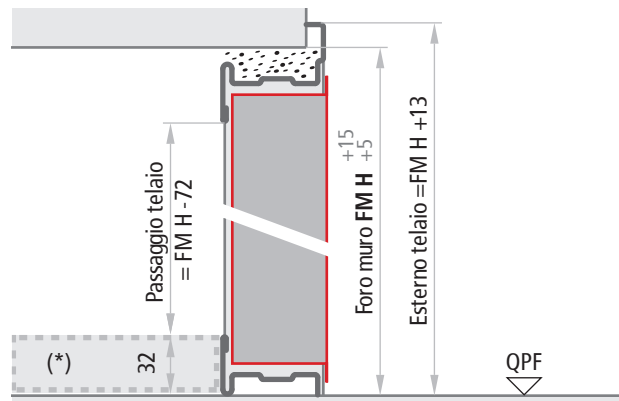

## Two-leaved doors

Horizontal cross section

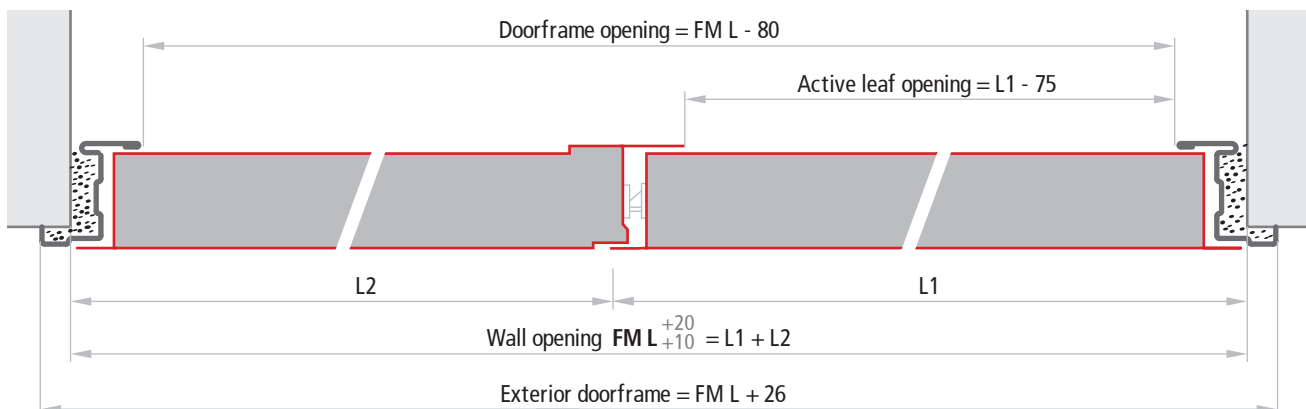

### Leaves thickness

MULTIPURPOSE 60 mm

### NOTE

The tolerances  $FM L +20 +10$ ,  $FM H +15 +5$  of the indicated measurements make it easier to fill the gap between the wall and the doorframe with cement mortar. For dry wall installation, the holes must be precise and greater tolerance ranges should not be employed.

\*) Shimming to be done, mandatory in case of installation onto emergency exit routes.

## ORDER MEASUREMENTS

### Wall opening

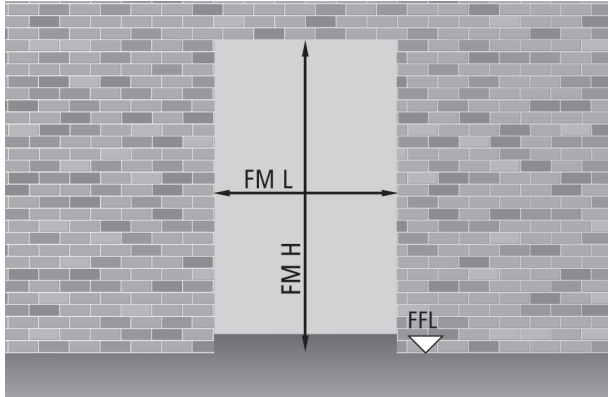

### Doorframe opening

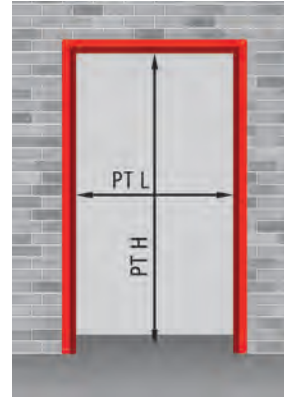

### One-leaved door FM L x FM H

#### standard dimensions

|      |   |                    |
|------|---|--------------------|
| 800  | x | 2050 / 2100 / 2150 |
| 900  | x | 2050 / 2100 / 2150 |
| 1000 | x | 2050 / 2100 / 2150 |
| 1100 | x | 2050 / 2100 / 2150 |
| 1200 | x | 2050 / 2100 / 2150 |
| 1300 | x | 2050 / 2100 / 2150 |
| 1350 | x | 2050 / 2100 / 2150 |

#### non-standard dimensions

from 500 to 1350 x from 1780 to 2200

### One-leaved doors

$$PT L = FM L - 74$$

$$PT H = FM H - 40$$

#### doorframe opening Two-leaved doors

|      |   |                    |
|------|---|--------------------|
| 826  | x | 2010 / 2060 / 2110 |
| 926  | x | 2010 / 2060 / 2110 |
| 1026 | x | 2010 / 2060 / 2110 |
| 1126 | x | 2010 / 2060 / 2110 |
| 1226 | x | 2010 / 2060 / 2110 |
| 1276 | x | 2010 / 2060 / 2110 |

### Two-leaved doors FM L (L1+L2) x FM H

#### standard dimensions

|      |               |   |                    |
|------|---------------|---|--------------------|
| 1150 | ( 750 + 400)  | x | 2050 / 2100 / 2150 |
| 1200 | ( 800 + 400)  | x | 2050 / 2100 / 2150 |
| 1250 | ( 800 + 450)  | x | 2050 / 2100 / 2150 |
| 1300 | ( 900 + 400)  | x | 2050 / 2100 / 2150 |
| 1350 | ( 900 + 450)  | x | 2050 / 2100 / 2150 |
| 1400 | (1000 + 400)  | x | 2050 / 2100 / 2150 |
| 1450 | (1000 + 450)  | x | 2050 / 2100 / 2150 |
| 1600 | ( 800 + 800)  | x | 2050 / 2100 / 2150 |
| 1700 | ( 900 + 800)  | x | 2050 / 2100 / 2150 |
| 1800 | ( 900 + 900)  | x | 2050 / 2100 / 2150 |
| 1900 | (1000 + 900)  | x | 2050 / 2100 / 2150 |
| 2000 | (1000 + 1000) | x | 2050 / 2100 / 2150 |

#### non-standard dimensions

from 900 (500+400) to 2000 (1000+1000) x from 1780 to 2200

### PT L x PT H

#### doorframe opening

|      |   |                    |
|------|---|--------------------|
| 1076 | x | 2010 / 2060 / 2110 |
| 1126 | x | 2010 / 2060 / 2110 |
| 1176 | x | 2010 / 2060 / 2110 |
| 1226 | x | 2010 / 2060 / 2110 |
| 1276 | x | 2010 / 2060 / 2110 |
| 1326 | x | 2010 / 2060 / 2110 |
| 1376 | x | 2010 / 2060 / 2110 |
| 1526 | x | 2010 / 2060 / 2110 |
| 1626 | x | 2010 / 2060 / 2110 |
| 1726 | x | 2010 / 2060 / 2110 |
| 1826 | x | 2010 / 2060 / 2110 |
| 1926 | x | 2010 / 2060 / 2110 |

from 826 to 1926 x from 1740 to 2160

### NOTE

Unless specified otherwise by the customer, two-leaved doors are supplied with a right-pull opening direction.

# Opening measurements - Overall dimensions

UNIVER multipurpose doors



UNIVER multipurpose

## OPENING MEASUREMENTS AND OVERALL DIMENSIONS WITH 90 DEGREE OPENING

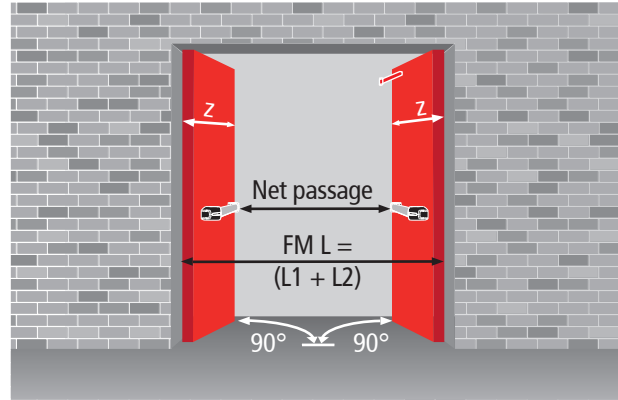
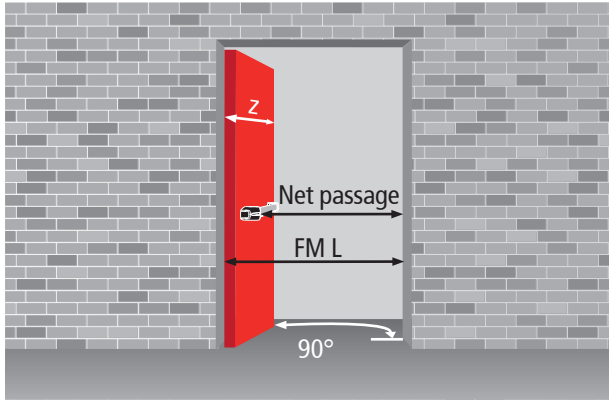

### Net passage calculation

| panic bar type                           | protrusion | one-leaved door | two-leaved door    |
|--|------------|-----------------|--------------------|
| EXUS                                     | 125        | FML - 236       | FML - 404          |
| TWIST                                    | 100        | FML - 211       | FML - 354          |
| SLASH                                    | 75         | FML - 186       | FML - 304          |
| FAST TOUCH                               | 75         | FML - 186       | FML - 304          |
| without panic bar                        | -          | FML - 111       | FML - 154          |
| z = leaf protrusion relative to the wall |            | FML + 29        | L1 + 35<br>L2 + 64 |

## OVERALL DIMENSIONS WITH 180 DEGREE OPENING - HANDLE HEIGHT

### One-leaved door

z = FML + 29      x = FML + 5  
h handle = FMH/2 + 50

### Two-leaved door

z = L1 + 35      x = L1 + 5  
z = L2 + 64      y = L2 + 35  
h handle = FMH/2 + 50

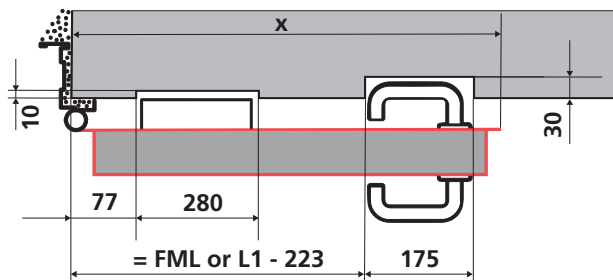
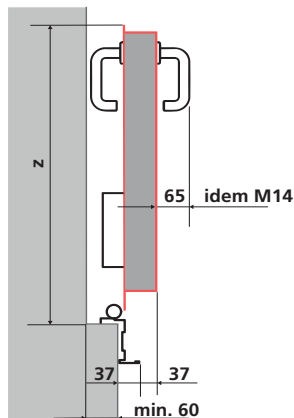
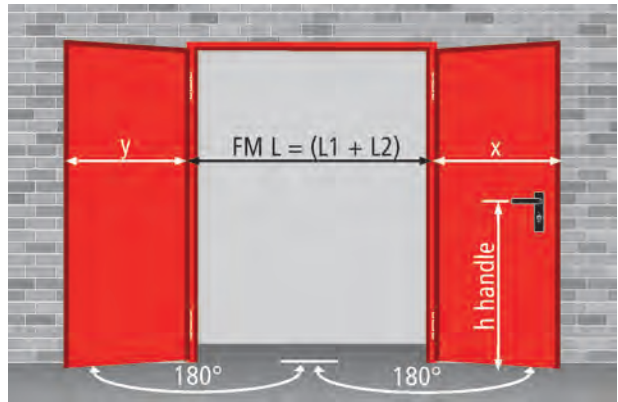
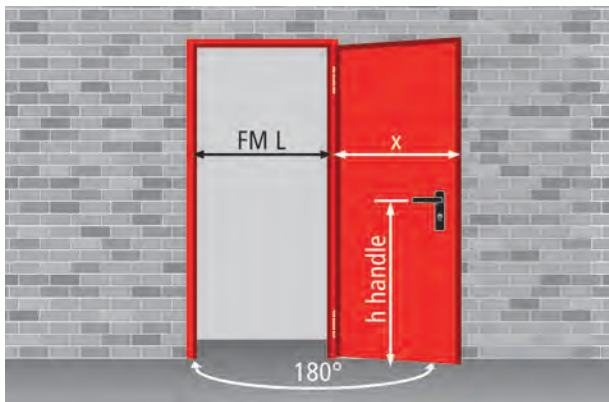



**"safer because they are sturdier"**

Ascensore/Lift  





## **PROGET NINZ Doors**

*MULTIPURPOSE VERSION*

|   |            |
|---|------------|
| FEATURES                                  | 92 - 95    |
| SPECIFIC OPTIONAL ACCESSORIES             | 96 - 105   |
| ADDITIONAL PERFORMANCES                   | 106 - 1013 |
| DOOR CROSS SECTIONS - MEASUREMENTS        | 114        |
| INSTALLATION METHODS                      | 115 - 116  |
| ORDER MEASUREMENTS - HANDLE HEIGHT        | 117 - 118  |
| OPENING MEASUREMENTS - OVERALL DIMENSIONS | 119        |

# Features

## PROGET multipurpose doors



PROGET  
multipurpose

### THE MULTIPURPOSE DOOR IN A CLASS OF ITS OWN

#### „Indisputable quality“

- Especially sturdy door for safe functioning over time
- Built to order for all kinds of requests
- Fully galvanized door, including the “hidden” parts
- Made of “Sendzimir” processed hot-galvanized sheet metal
- Corrosion protection also provided along cut edges of the metal sheets
- Painted with epoxy-polyester thermoset powders in a 180 degrees (Celsius) oven
- Substantial paint layer (70 microns plus)
- Optimal corrosion resistance demonstrated by 500 hour salt-fog test
- Unaffected by severe climate changes, demonstrated by 2000 hours with +60° to -10° cycles at 75% humidity
- Finishing with high-quality aesthetics
- Orange skin anti-scratch structured paint
- Customizable with wide selection of RAL colors

#### CE marking for external use

- Wind resistance and water tightness
- Acoustic and thermal isolation
- Air permeability
- Suitable for use with panic bar

#### “Practicality of use“

- Truly sturdy frame that facilitates anchoring to the wall
- Suitable for all types of walls
- Ample size range
- Wide variety of accessories
- Easy installation

#### “Versatility“

- Very wide field of application
- Can be combined with various frame types
- Installation onto any wall type
- Installation with a block frame possible

#### “Manufacturing technology“

- Manufacturing in modern and functional facilities which employ the latest technologies to maintain high quality levels and product uniformity
- The entire production process - from raw materials to painted and packaged products - takes place inside Ninz's own facilities, ensuring a 360 degree door control

#### Opening direction

Opening direction needs to be indicated while ordering

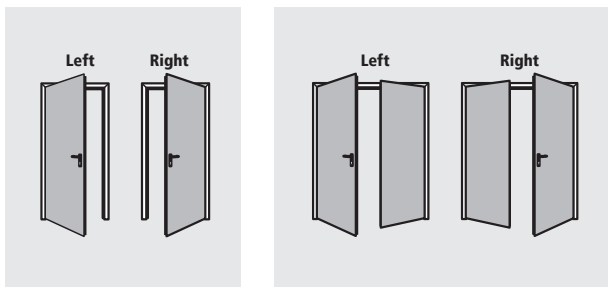

One-leaved doors



Two-leaved doors

# Features

PROGET multipurpose doors

**NINZ**<sup>®</sup>  
FIRE DOORS

PROGET  
multipurpose

## STANDARD ELEMENTS

### Door leaf

- Made of "Sendzimir" processed hot-galvanized sheet metal, press folded and electro welded
- Perimetral rebate on 3 sides, flat at the bottom
- Internally reinforced with hot-galvanized steel profiles
- Heat-insulated treated mineral wool packing that is rigidly joined to the sheet metal
- Internal stiffeners for overhead door closer and panic bar
- Thickness of 60mm

### Standard frame

- Sturdy profile with a sizeable cross section
- Made of "Sendzimir" processed hot-galvanized sheet metal
- Equipped with special assembly brackets
- Grooves for rebate sealing
- Standard installation via anchors for mortar fixing
- Upon request installation via expansion or installation screws (delivered without wall anchors)
- Lower spacer, mounting template
- Rests on finished flooring without rebate
- Strike plates in black plastic for lock bolt and safety bolts
- Assembly required for doorframes



### Hinges

- Nr. 2 three-wing hinges for each leaf
- of which one ball-bearing hinge with screws for vertical adjustment of the leaf, **CE** marked as per EN 1935, classified for up to 160 kg load, 200.000 cycles durability, suitable for fire door use
- and one hinge with self-closing spring

### Safety bolts

- Nr. 1 sturdy safety bolt applied on hinge side leaf edge

### Locking mechanism

- Reversible locking mechanism with bolt and central latch
- Insert with patent key, Euro profile cylinder ready

### Handle

- Handle in black plastic with steel core
- Steel installation plate with cylinder hole
- Cover plate in black plastic
- Fastener screws and patent key insert

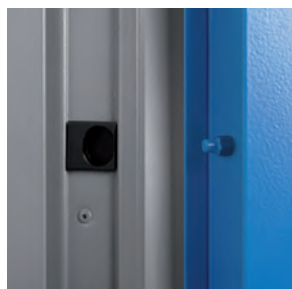

# Features

## PROGET multipurpose doors



PROGET  
multipurpose

### INCLUDED ACCESSORIES

#### Locking mechanism on inactive leaf

- "Flush-bolt" automatic latching of the inactive leaf
- Lever control for unlocking

#### Upper coupling system for the inactive leaf

- Inactive leaf lock activated device which inserts rod into the upper strike box
- Upper strike box in pierced steel with steel roller

#### Lower coupling system for the inactive leaf

- Vertical rod with steel point which inserts into lower strike box
- Lower floor catch (floor-mounted bushing) made of black plastic with rebate stopper

#### Identification plate

- Metal tag with door identification data



Standard paint - group 01: RAL 9010

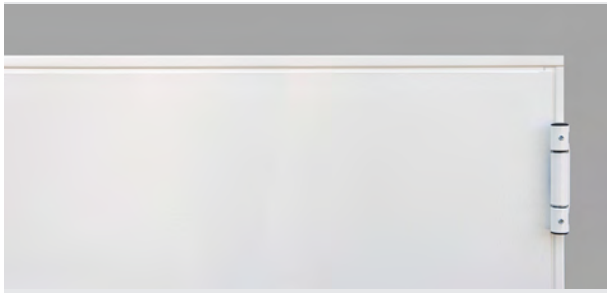

### Finishing

- Standard paint with epoxy-polyester thermoset powders in a 180 degrees oven, orange skin, anti-scratch finishing
- Standard paint RAL 9010

### Standard packaging

- Single leaf wrapped into stretchable polyethylene (PE) film
- Single packaging for each doorframe with stretchable polyethylene (PE) film
- Palletized on wooden pallets

### NOTE

If the door ever needs to be repainted, follow the precise instructions on the "Painting" page.

# Features

PROGET multipurpose doors

**NINZ**<sup>®</sup>  
FIREDOORS

## OPTIONAL ACCESSORIES

A wide variety of accessories and surface finishes are available on request for maximum value enhancement of Proget doors to your own specific needs.

The proper accessories can help resolve:

### Safety-related needs

- Doors for panic exits (see panic bars)
- Doors for emergency exits (see emergency exit handles)
- Three-point locking mechanism

### Installation and utilization needs

- Special frames
- Frame extensions
- Different kinds of floor mounted catches
- Roofing and drip steel-profile
- Special installation screws
- Kick and protection plates in stainless steel
- Rectangular windows, standard or built to order
- Round windows
- Wide variety of louvers
- One-leaved door with frame on four sides

### Access-related control issues

- Electrically-activated lock mechanisms
- Electric handle mechanisms
- Magnetic blocking mechanisms

### Performance enhancing

- Sealing
- Cylinders
- Door closers
- Special handles



PROGET  
multipurpose



### Customized finishing

- Select finishing from a wide variety of RAL colours
- NDD – Ninz Digital Decor, graphic images applied with special ink jets and protected by a transparent topcoat. Infinite varieties of customizable decorations in harmony with specific door settings
- Stainless steel handles
- Colored handles

### Packaging for maximum protection

Sturdy wooden crates protect all doors and related accessories

- For NDD decorated doors
- On construction sites
- During shipping abroad
- For special transport

### NOTE

Details about optional accessories may be found in the present brochure in chapters:

- Painting and NDD decorations
- Accessories for metal doors
- Emergency handles and panic bars

## MULTIPURPOSE WINDOW WITH METAL WINDOW FRAME

Upon request one- and two-leaved doors may be equipped with round or rectangular windows, with different types of glass and respective window frames fixed with screws. The window frame carters are included for round window and available as an optional accessory for the rectangular one.

### Production limits

Window sizes are standard and the minimum border strips around the window may not be reduced.

### Borders, window position

"Border measurement" refers to the distance from the edge of the window to the wall opening of the door.

### Elevation for round windows

| window dimensions | FM H              | position     |
|-------------------|-------------------|--------------|
| Ø 300             | minimum 1950      | Y=1600       |
| Ø 300             | less than 1950    | Y=FM H - 350 |
| Ø 400             | minimum 2150      | Y=1600       |
| Ø 400             | from 1950 to 2149 | Y=1550       |
| Ø 400             | less than 1950    | Y=FM H - 400 |

### Elevation for rectangular windows

| window dimensions L x H | FM H              | position                   |
|-------------------------|-------------------|----------------------------|
| 250/300/400 x 400       | minimum 2150      | Z=1450                     |
| 250/300/400 x 400       | from 1950 to 2149 | Z=1350                     |
| 250/300/400 x 400       | less than 950     | Z=FM H - 600               |
| 400 x 600               | minimum 2150      | Z=1250                     |
| 400 x 600               | from 1950 to 2149 | Z=1150                     |
| 400 x 600               | less than 1950    | Z=FM H - 800               |
| 400 x 1200              | minimum 2150      | Z=650                      |
| 400 x 1200              | from 1950 to 2149 | Z=550                      |
| 400 x 1200              | less than 1950    | Z=FM H - 1400              |
| min. 250 x 250          |                   | Z=as indicated by customer |

### Borders, window position

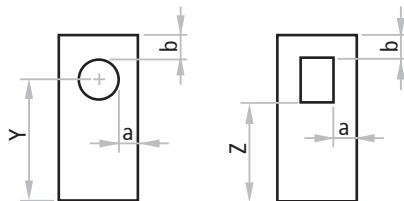

### NOTE

For the rectangular windows the frame carters are an optional accessory

### Round window cross section

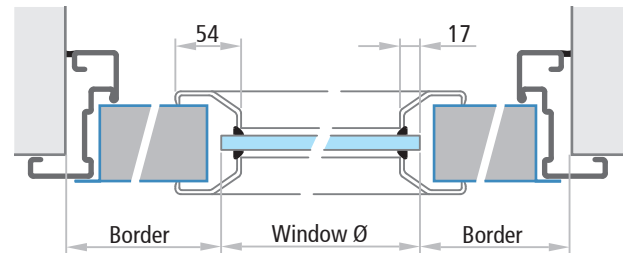

### Rectangular window cross section

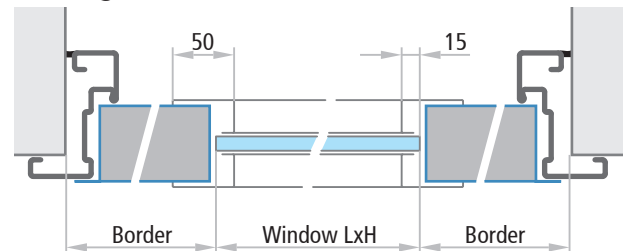



# Specific optional accessories - Windows

PROGET multipurpose doors

















PROGET multipurpose

| Window dimensions  | min. border |     | dimensions FM L min.               |    |
|--|-------------|-----|------------------------------------|----|
|  | a           | b   | L1                                 | L2 |
|  Ø 300<br>Ø 400 | 200         | 200 | 700<br>800                         |    |
|  Ø 300<br>Ø 400 | 200         | 200 | L1 700 + L2 350<br>L1 800 + L2 350 |    |
|  Ø 300<br>Ø 400 | 200         | 200 | L1 700 + L2 700<br>L1 800 + L2 800 |    |

| Glasses available  | shapes                         |
|--|--------------------------------|
| laminated, 2B2 rated   | 3 + 3 mm rectangular, circular |
| laminated, 2B2 rated   | 4 + 4 mm rectangular           |
| low emission double glass window with 2 laminated glazings 2B2 rated | 3+3 / 12 / 3+3 mm rectangular  |

**NOTE**  
Position and measurements indicated above are those standard.  
Different positions may be considered as long as they respect the minimum "a" and "b" border strips. The window itself may not be supplied separately except for replacements. It is always advisable for doors with windows to be equipped with door closers for controlled closing.

| Window dimensions  | min. border |     | dimensions FM L min. |    |
|--|-------------|-----|----------------------|----|
|  | a           | b   | L1                   | L2 |
|  250 x 400  | 200         | 200 | 650                  |    |
|  300 x 400  | 200         | 200 | 700                  |    |
|  400 x 400  | 200         | 200 | 800                  |    |
|  400 x 600  | 200         | 200 | 800                  |    |
|  400 x 1200 | 200         | 200 | 800                  |    |
| Windows made to order min.250x250  | 200         | 200 | 650                  |    |
|  250 x 400  | 200         | 200 | L1 650 + L2 350      |    |
|  300 x 400  | 200         | 200 | L1 700 + L2 350      |    |
|  400 x 400  | 200         | 200 | L1 800 + L2 350      |    |
|  400 x 600  | 200         | 200 | L1 800 + L2 350      |    |
|  400 x 1200 | 200         | 200 | L1 800 + L2 350      |    |
| Windows made to order min.250x250  | 200         | 200 | L1 650 + L2 350      |    |
|  250 x 400  | 200         | 200 | L1 650 + L2 650      |    |
|  300 x 400  | 200         | 200 | L1 700 + L2 700      |    |
|  400 x 400  | 200         | 200 | L1 800 + L2 800      |    |
|  400 x 600  | 200         | 200 | L1 800 + L2 800      |    |
|  400 x 1200 | 200         | 200 | L1 800 + L2 800      |    |
| Windows made to order min.250x250  | 200         | 200 | L1 650 + L2 650      |    |

## MULTIPURPOSE WINDOW WITH RUBBER WINDOW FRAME

On request, one- and two-leaved doors may be equipped with round or rectangular windows, with laminated 3+3mm glass, 2B2 rated, framed with a black rubber EPDM profile.

The corners of rectangular windows are rounded (radius of approx. 100mm).

### Production limits

Window sizes are standard and the minimum border strips around the window may not be reduced.

### Borders, window position

"Border measurement" refers to the distance from the edge of the window to the wall opening of the door.

### Elevation for round windows

| window dimensions | FM H           | position     |
|-------------------|----------------|--------------|
| Ø 300             | minimum 1950   | Y=1600       |
| Ø 300             | less than 1950 | Y=FM H - 350 |
| Ø 400             | minimum 2000   | Y=1600       |
| Ø 400             | less than 2000 | Y=FM H - 400 |

### Elevation of rectangular windows

| window dimensions L x H | FM H           | position     |
|-------------------------|----------------|--------------|
| 300 x 500               | minimum 1950   | Z=1500       |
| 300 x 500               | less than 1950 | Z=FM H - 450 |
| 400 x 700               | minimum 2050   | Z=1500       |
| 400 x 700               | less than 2050 | Z=FM H - 550 |

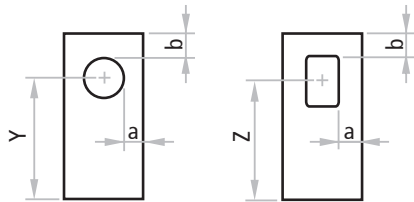

### NOTE

The positions indicated above are those standard. Different positions may be considered as long as they respect the minimum "a" and "b" border strips. The window itself may not be supplied separately except for replacements. It is always advisable for doors with windows to be equipped with door closers for controlled closing.



### Round and rectangular window cross sections

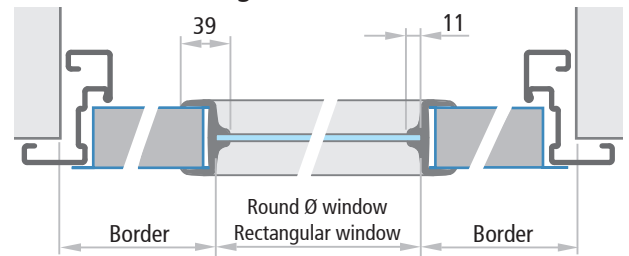

### Window dimensions

| Window dimensions      | minimum border |     | FM L min. dimensions               |
|------------------------|----------------|-----|------------------------------------|
|                        | a              | b   |                                    |
| Ø 300<br>Ø 400         | 200            | 200 | 700<br>800                         |
| Ø 300<br>Ø 400         | 200            | 200 | L1 700 + L2 350<br>L1 800 + L2 350 |
| Ø 300<br>Ø 400         | 200            | 200 | L1 700 + L2 700<br>L1 800 + L2 800 |
| 300 x 500<br>400 x 700 | 200            | 200 | 700<br>800                         |
| 300 x 500<br>400 x 700 | 200            | 200 | L1 700 + L2 350<br>L1 800 + L2 350 |
| 300 x 500<br>400 x 700 | 200            | 200 | L1 700 + L2 700<br>L1 800 + L2 800 |

# Specific optional accessories

PROGET multipurpose doors



PROGET multipurpose

## VENTILATING LOUVERS WITH METAL FRAMES

To permit continuous air movement through the door, different types of ventilating louvers are available upon request in standard or non-standard formats. The screw-on metal frames for the ventilating louvers are painted the same color as the leaf using thermoset epoxy-polyester powders. On request air flow estimates calculated by a special program can be supplied for the dimensions of the ventilating louvers.

The vertical position of the louvers needs to be indicated on the order.

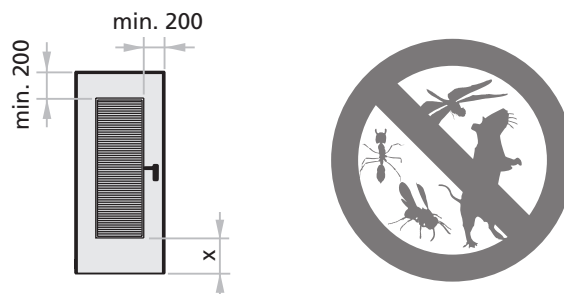

x = min. 200 mm for louver heights up to 1200 mm  
 x = min. 500 mm for louver heights over 1200 mm

### Louver with steel grate plates

Louver with steel grate plates only. Standard production employs angled steel grate plates that slope downwards in the same direction as the door pull.

| Dimensions L x H | estimated air flow   |
|------------------|----------------------|
| 300 x 400        | 500 cm <sup>2</sup>  |
| 400 x 600        | 1200 cm <sup>2</sup> |
| 400 x 1200       | 2600 cm <sup>2</sup> |
| to order         | on request           |

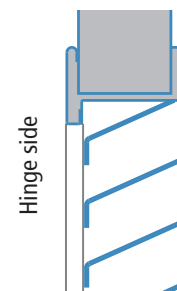

### Louver with steel grate plates and anti-insect mesh

Louver with steel grate plates overlaid with a metal anti-insect mesh (6,3x6,3x0,55mm sheet). Standard production employs angled steel grate plates that slope downwards in the same direction as the door pull.

| Dimensions L x H | estimated air flow   |
|------------------|----------------------|
| 300 x 400        | 300 cm <sup>2</sup>  |
| 400 x 600        | 800 cm <sup>2</sup>  |
| 400 x 1200       | 1800 cm <sup>2</sup> |
| to order         | on request           |

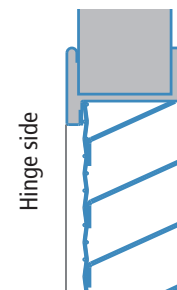

### Anti-rodent mesh

Metal frame with metal anti-rodent mesh only (16x16x3mm sheet).

| Dimensions L x H | estimated air flow   |
|------------------|----------------------|
| 300 x 400        | 700 cm <sup>2</sup>  |
| 400 x 600        | 1600 cm <sup>2</sup> |
| 400 x 1200       | 3300 cm <sup>2</sup> |
| to order         | on request           |

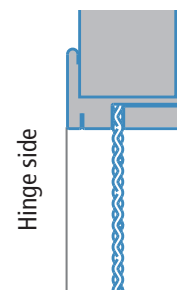
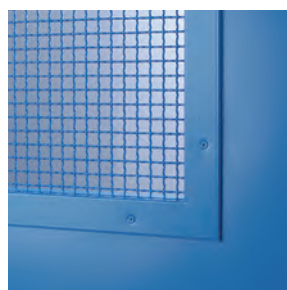

# Specific optional accessories

## PROGET multipurpose doors

### FRAME EXTENSIONS FOR PROGET DOORS

#### IM 1

Frame extension to be mounted in addition to the Proget acting as a wall cladding. Made of "Sendzimir" processed hot-galvanized sheet metal and painted the same color as the doorframe with epoxy-polyester powders. Profile on three sides, upper corners with 45 degree joint, fixing with screws and plugs in groove (screws and plugs not included).

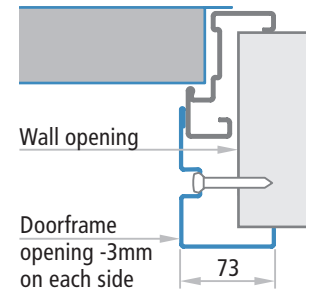
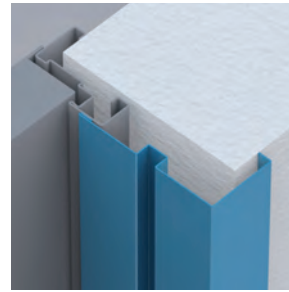

#### IM 3

Frame extension to be mounted in addition to the Proget acting as a wall cladding. Made of "Sendzimir" processed hot-galvanized sheet metal and painted the same color as the doorframe with epoxy-polyester powders. Profile on three sides, upper corners with 45 degree joint, fixing with screws and plugs (screws and plugs not included).

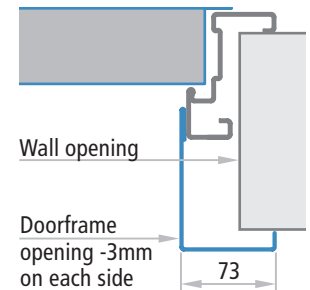
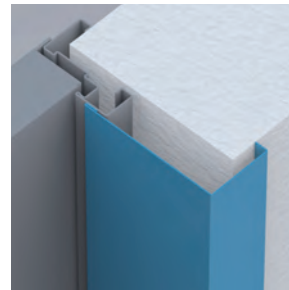

#### IM 4

Frame extension to be screwed to the Proget doorframe acting as a wall cladding. Made of "Sendzimir" processed hot-galvanized sheet metal painted the same color as the doorframe with epoxy-polyester powders. Profile on three sides, upper corners with 90 degree joint. Complete with fastener screws. To mount the frame extension, pre-drilled holes are available on the frame. Combine with sealing to conceal the screw heads.

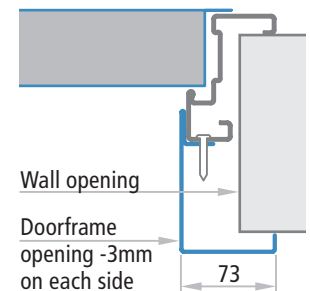
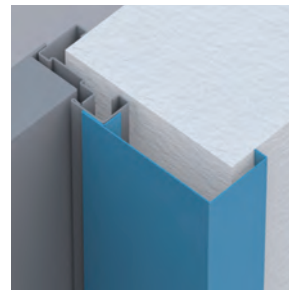

#### IM 5

Telescopic frame extension to be screwed to the Proget doorframe acting as a wall cladding for expansion screw fixing. Consists of two overlapping profiles with a 25mm adjustable range. Made of "Sendzimir" processed hot-galvanized sheet metal painted the same color as the doorframe with epoxy-polyester powders. Profile on three sides, upper corners with 90 degree joint. Complete with fastener screws. To mount the frame extension, pre-drilled holes are available on the frame. Combine with sealing to conceal the screw heads.

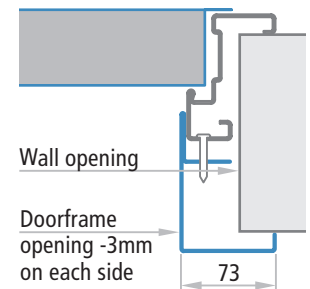
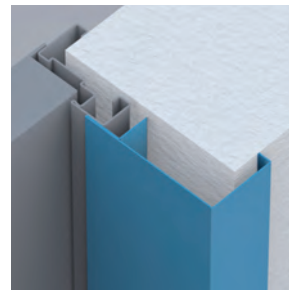

### FRAME ON FOUR SIDES

Upon request one-leaved Proget doors may be supplied with frames on four sides and leaves with or without lower rebate. These type of doors are used mainly for technical rooms or shafts.

The frame on four sides is not available for the following applications: doors installed onto escape routes, two-leaved doors, external doors C€ marked, application with embracing frame or block frame for in the reveal application, in combination with frame extensions.

#### ATTENTION

With the frame on four sides, the center of the handle will be 15 mm higher than the standard position. For more details, see the page "Door cross section - Measurements".

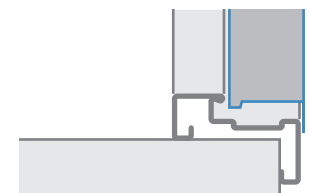

Leaf with lower rebate

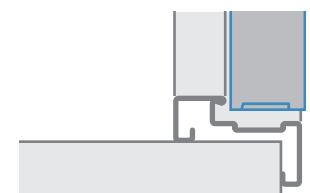

Leaf without lower rebate

# Specific optional accessories

PROGET multipurpose doors



PROGET multipurpose

## SPECIAL FRAMES FOR PROGET MULTIPURPOSE DOORS

Embracing three sided frame for Proget multipurpose doors with 45 degree corner joints, made of 1,5mm thick "Sendzimir" processed galvanized steel sheets. To be screwed to finished walls, including joints for assembly, hole-covering caps, sealing and RAL painting with thermoset epoxy-polyester powder paints. Pre-drilled screw holes present on the doorframe. Installation screws not included.

Order measurements = FM

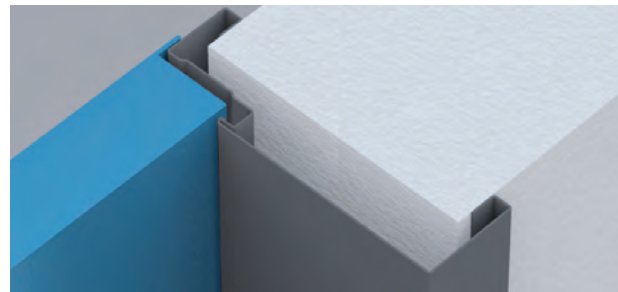
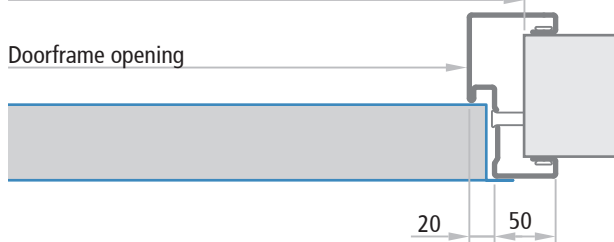

Minimum wall thickness for multipurpose doors = 70 mm

| Order measurements | required wall opening | doorframe opening |
|--------------------|-----------------------|-------------------|
| FM L (width)       | FM L                  | FM L - 80 mm      |
| FM H (height)      | FM H                  | FM H - 40 mm      |

## BLOCK FRAME FOR IN THE REVEAL (TUNNEL) APPLICATIONS

Three sided block frame application of Proget multipurpose doors, made of 1,5mm thick "Sendzimir" processed galvanized steel sheets. To be screwed to finished walls and equipped with integrated attachment shackles. Includes assembly joints, hole-covering caps, sealing and RAL painting with thermoset epoxy-polyester powder paints. Pre-drilled screw holes present on the doorframe. Installation screws not included.

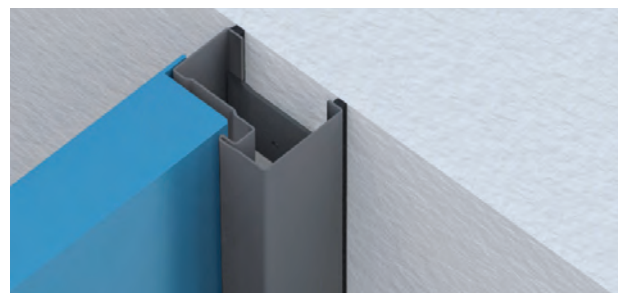

## One-leaved doors - Horizontal cross section

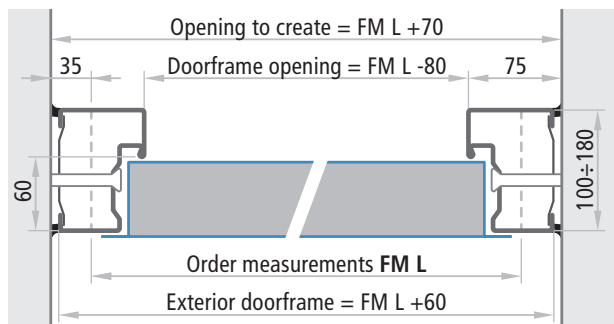

## Doors without lower threshold - Vertical cross section

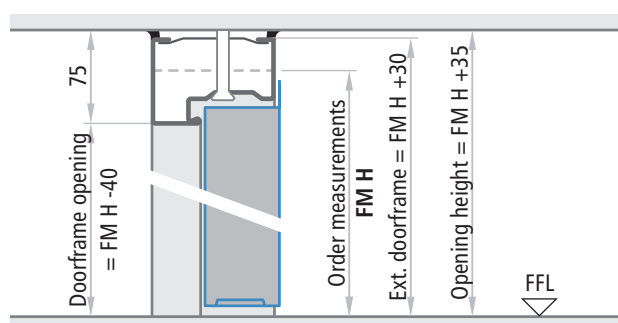

## Two-leaved doors - Horizontal cross section

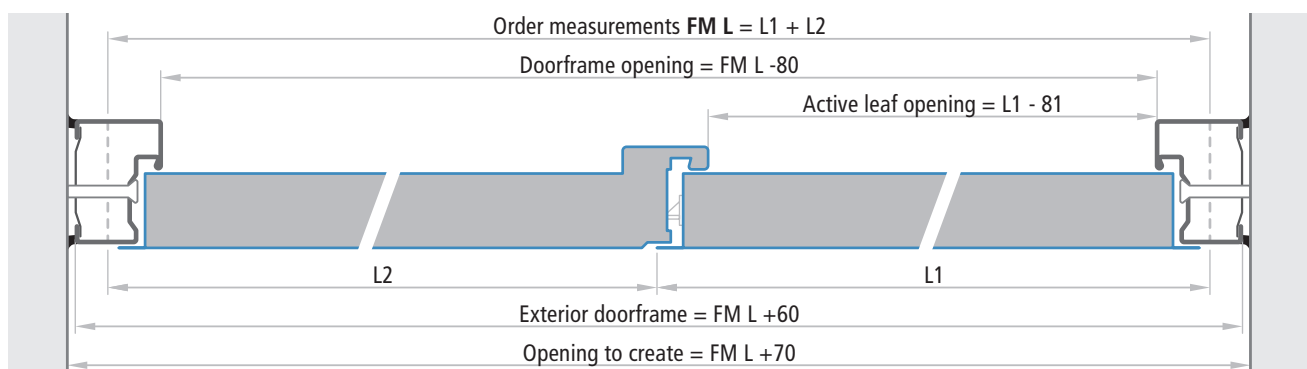

# Specific optional accessories

## PROGET multipurpose doors



PROGET  
multipurpose

### PROGET OVERHEAD FRAME PANEL

Available for the installation with Proget one- and two leaved doors in following versions: blank filled with metal sheet from both sides (without insulation), with ventilation steel louver or with glazing bead (glass not supplied); all painted in the same color as doorframe with epoxy-polyester thermoset powders. Profiled on four sides with the standard angular- for in the reveal application- embracing-frame profiles, corners with 45 degree joint. In case of standard doorframe is supplied with an "C" shaped profile to be fixed upon the top frame of the door and shall be drilled on site for the fastening upon door and wall. In case of embracing or block frames, pre-drilled holes are available (screws and anchors not supplied).

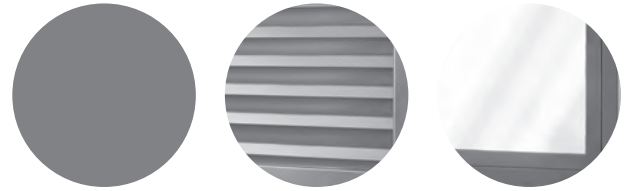

blank filled with metal sheet

with ventilation steel louver

with glazing bead (glass not supplied)

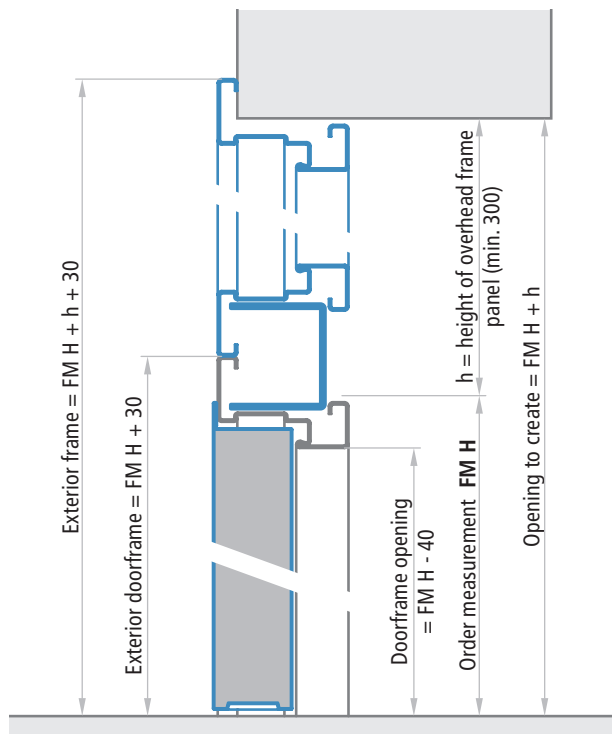
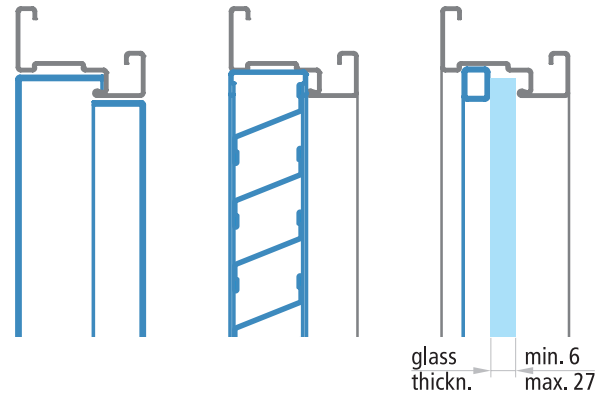
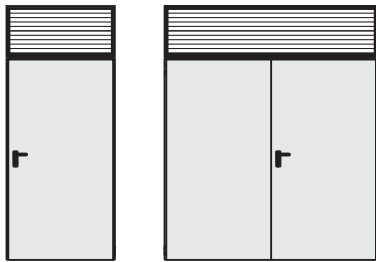

vertical cross section of the door with overhead panel and standard angular doorframe)

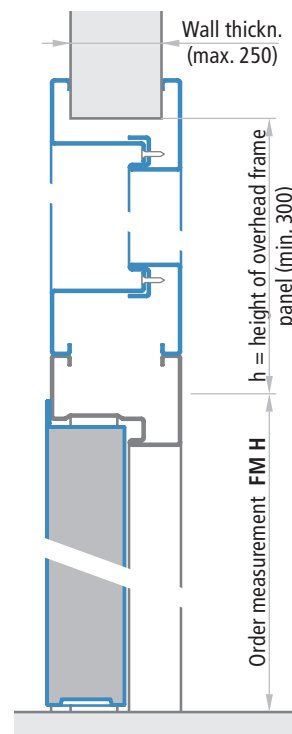

with embracing doorframe

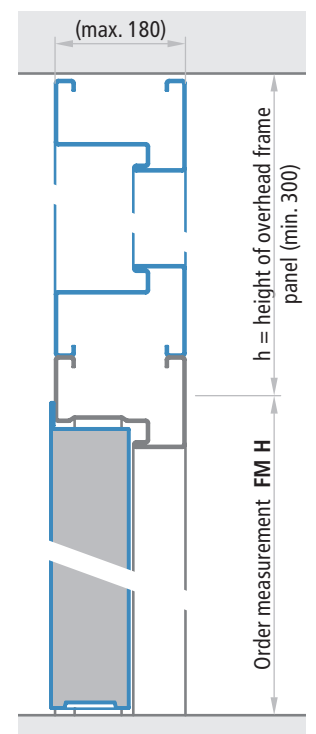

with block frame

#### NOTE

In case of overhead frame panel with glazing bead, the thickness of glass (not supplied) min. 6 mm and max. 22 mm must be specified.

Standard frame calculus of window dimension:  $FM L - 45 \text{ mm} \times h - 105 \text{ mm}$

Embracing frame calculus of window dimension:  $FM L - 45 \text{ mm} \times h - 105 \text{ mm}$

Block frame calculus of window dimension:  $FM L - 45 \text{ mm} \times h - 140 \text{ mm}$

# Specific optional accessories

PROGET multipurpose doors



PROGET multipurpose

## DOOR WITH EXTENDED FRAME

For one-leaved Proget doors only. Frame extends beyond the door leaf to create a gap below the door with height (h) varying of between 50 to 200 mm. Using the standard Proget door leaf and an extended the frame, the desired handle height (QCM) must be specified when ordered. In the absence of such indication, the QCM will be 1050mm.

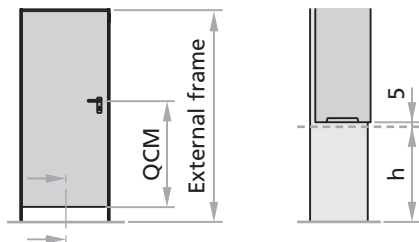

| Standard handle height | external frame  | opening to create |
|------------------------|-----------------|-------------------|
| 1050                   | $FM H + h + 30$ | $FM H + h$        |

**NOTE**  
Not available for multipurpose doors Proget with  $\text{C}\epsilon$  marking.

## MORTICE LOCK WITH ROLLER LATCH AND G1X DOUBLE FIX GRAB DOOR HANDLE IN STAINLESS STEEL

For multipurpose one- or two-leaved Proget doors. Designed to permit free pedestrian passage, by simply pushing or pulling the door by the fix grab.

Usually the lock is not locked by key, thus the opening is possible by simple pulling or pushing, disengaging the roller latch. It is possible to regulate the engagement force of the roller latch, by turning the regulation screw visible on the cover plate of the lock. By locking the lock by key, the dead bolt blocks the opening of the door from both sides.

Included (factory mounted to the door): mortice lock with roller latch and central dead bolt activated by the cylinder; included (supplied on the side): item G1X which comprises a pair of brushed fix grab door handles in stainless steel (diameter 30mm, length 400mm, projection 90mm), a fixing kit for the handles to the door and a pair of escutcheons in brushed stainless steel with cylinder hole for euro profile cylinder (cylinder excluded, to be ordered separately).

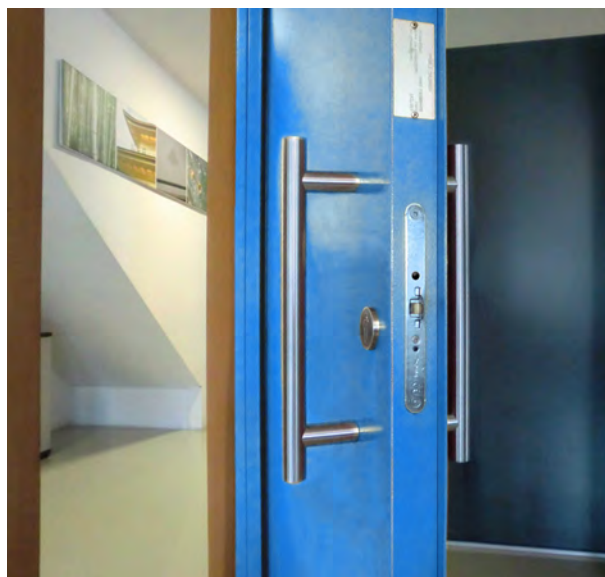

Mortice lock with roller latch and G1X: pair of brushed fix grab door handles in stainless steel, installed on multipurpose Proget door

**NOTE**  
Not available for multipurpose doors Proget with  $\text{C}\epsilon$  marking.

# Specific optional accessories

## PROGET multipurpose doors



### VENTILATION LOUVER

Ventilation louver made of either black or white PVC, 482x99mm (air passage approx. 150cm<sup>2</sup>). The opening direction of the door needs to be specified.

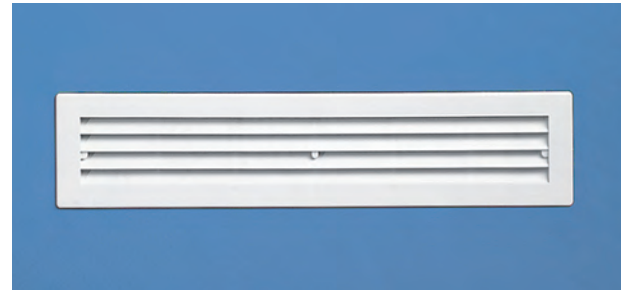
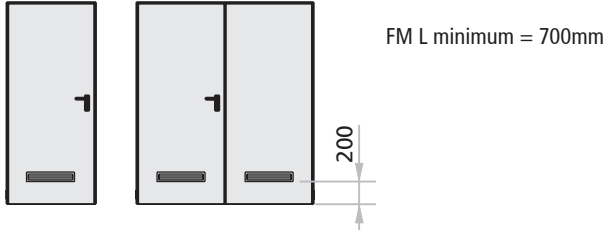

#### Dimensions

482 x 99

#### Estimated air flow

150 cm<sup>2</sup>

#### NOTE

Not available for multipurpose doors Proget with **CE** marking.

### THREE-POINT LOCKING MECHANISM

Upon request for a more reliable closure, one- and two-leaved Proget multipurpose doors may be delivered with a three-point lateral lock. In combination with double M1 handle and cylinder. The lock is also available for anti-panic and emergency push versions. Thus the three-point locking mechanism can be combined with emergency handles or with EXUS, TWIST, SLASH type BM panic bars in conformity with **CE** marking.

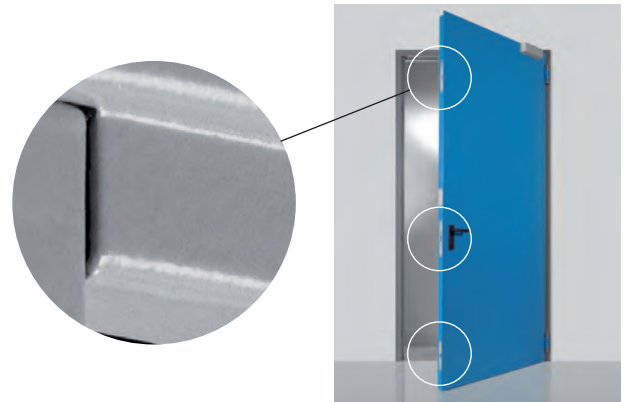
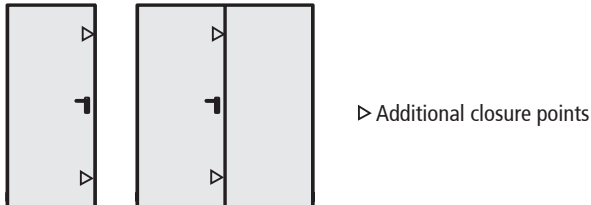

#### NOTE

Three point locking mechanism can be combined with M1, M1C, M1X, M1Xs, M11, M11X and M11Xs handles only.

### CR REBATE SEALING

CR sealing in black extruded profile to cut and to be pressed into the dedicated groove in the perimetral frame and on the central joint of two-leaved doors.

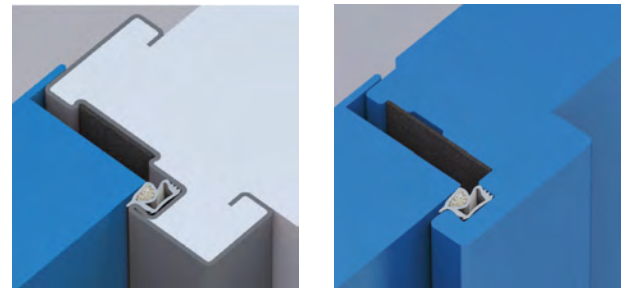

## Specific optional accessories

PROGET multipurpose doors

**NINZ**<sup>®</sup>  
FIRE DOORS

### STEEL FLOOR CATCH

Floor-mounted steel floor catch for two-leaved Proget doors. Made of pierced and successively galvanized steel. Includes rebate stop for the inactive leaf, the strike box for insertion of the rod, Nr. 3 screws and Nr. 3 plugs. To be used in place of the plastic floor catch for doors that usually remain open and where carts and heavy equipment pass on a regular basis.

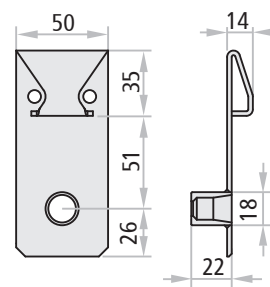

### RETREATING FLOOR CATCH „N626“

To be applied in combination with two-leaved PROGET doors, which are usually to be kept open, in substitution of the standard floor catch. The N626's advantage is the embedding of the floor catch into the floor which is activated only by the closing of the inactive leaf. Thus when the doors are open protrusions are avoided guaranteeing nevertheless a correct closing.

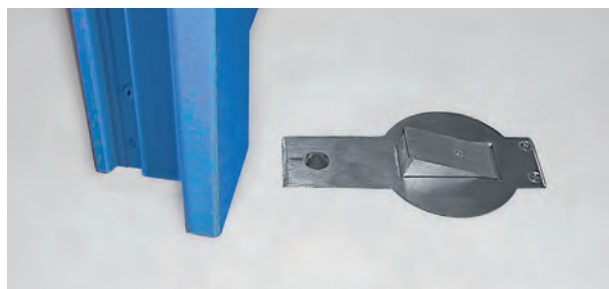

#### NOTE

For the passing of the cable of the command function the installation into the floor of a wrinkled cable sleeve is necessary. The installation of the N626 requires trained personnel.

### THRESHOLD

Fixed threshold in anodized aluminium supplied with relative rebate sealing. To be installed for single and double leaved doors onto the floor with screws and plugs (not supplied).

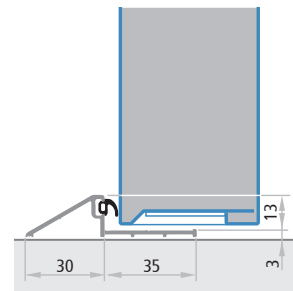
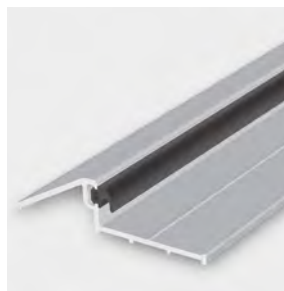

#### NOTE

This device is delivered only when the door has been ordered with **CE** conformity for external use. For the installation it is necessary to adapt the threshold to the frame of the door and to drill a hole for its fixing. Further it is necessary to finish up the threshold with silicone.

PROGET  
multipurpose

# Additional performances

PROGET multipurpose doors - concerned norm EN 14351-1:2006+A2:2016

**NINZ**<sup>®</sup>  
FIRE DOORS

PROGET  
multipurpose

## EXTERNAL PEDESTRIAN DOORS



Certificate CE 1404 - CPR -3738  
EN 14351-1:2006+A2:2016 ed EN 16034:2014

The norms EN 14351-1 ed EN 16034 define as an external door, a door which separates the internal from the external climate of a construction. For this use the doors need to be **CE** marked according to the norms EN 14351-1:2006+A2:2016 and EN 16034:2014 and if the door is installed within an emergency exit route, which means that a panic handle or bar is installed onto it, then the door also requires a conformity declaration of type 1 and further a **CE** Certificate issued by a notified body, which for NINZ S.p.A is the declaration 1404 - CPR - 3738

For Proget doors for external use order the relative Combos listed in the Proget multipurpose price list. Refer to the essential requirements listed in the table on the next page to select the correct version in conformity with the valid national standards.

In this way every door will be delivered with the **CE** marking and relative documentation conform to the valid standard.

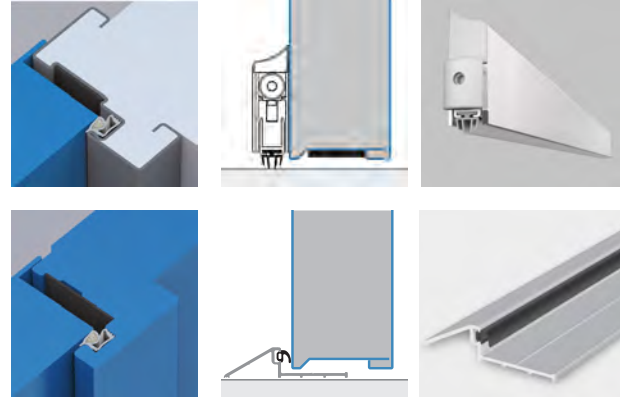

### ATTENTION

For the dimensional limits, minimum border measurements or production possibilities please refer to the specific pages of this brochure.

The values for the thermal transmittance  $W/m^2K$  shown in the table on the next page are given by the calculation according to the norm EN ISO 10077-1 done on samples of the dimensions 1,23x2,18 for areas  $\leq 3,6m^2$  and on samples of the dimensions 2,00x2,18 for areas  $> 3,6m^2$ .

All performance values indicated in the table are valid only in presence of the following accessories or enhancements:

- standard angular- for in the reveal application- embracing-frame
- isolation of the door frame with the filling of polyurethane foam
- installation of rubber seals along the entire perimeter of the door frame including the central rebate for double leaved doors
- sealing of the perimeter of the frame (side to push) with neutral silicone
- presence of the automatic door sweep or the fixed lower threshold depending upon selected solution
- for doors with windows: dimensions of 300x400mm for "3+3 / 12 / 3+3" low emission double glass windows, composed of two 3+3 laminated glazings, 2B2 rated.

In case of windows up to a maximum size of max 400x600mm the differing performance value for the thermal transmittance needs to be asked, all other performance values remain unchanged.

For the acoustic isolation performance values, in case of asymmetric double leaved doors ( $L1 \neq L2$ ), select the minor  $R_w$  value of the two.

example 1: leaf without windows and  $H=2150$ ,  $L1=1000$ ,  $L2= 500$  select 30 dB;

example 2: leaf without windows and  $H=2150$ ,  $L1=1200$ ,  $L2=1000$  select 32 dB.

### NOTE

For more details regarding the external installation, refer to the "Notices" section at the end of this brochure.



**SLOVENSKA  
AKREDITACIJA**  
ZAVOD ZA  
CP-002



**ZAG**  
ZAVOD ZA  
GRADBENSTVO  
SLOVENIJE  
SLOVENIAN  
NATIONAL BUILDING  
AND CIVIL ENGINEERING  
INSTITUTE  
Drovoška 12  
1000 Ljubljana  
Slovenija  
info@zag.si  
www.zag.si  
Notified certification body  
NB 1804

**Certificate  
of constancy of performance**

**1404 – CPR – 3738**

In compliance with Regulation (EU) No 305/2011 of the European Parliament and of the Council of 9 March 2011 (the Construction Products Regulation or CPR), this certificate applies to the construction product

**Single and double leaf door PROGET MULTI**  
(doors that fall within the scope of standard EN 14351-1:2006+A2:2016)

placed on the market under the name or trade mark of  
**NINZ S.p.A.,**  
**Corso Trento 2, 38061 Ala (TN), Italy**

and produced in the manufacturing plants  
**NINZ S.p.A.,**  
**Corso Trento 2, 38061 Ala (TN), Italy**  
and  
**NINZ S.p.A.,**  
**Via Negrelli 17, 39100 Bolzano, Italy.**

This certificate attests that all provisions concerning the assessment and verification of constancy of performance described in Annex ZA of the standards

**EN 16034:2014 and EN 14351-1:2006+A2:2016**  
under system 1 for the performance set out in this certificate are applied and that the factory production control conducted by the manufacturer is assessed to ensure the

**constancy of performance of the construction product.**

This certificate was first issued on 4. 6. 2024 and will remain valid until 4. 6. 2029 as long as neither the harmonised standards, the construction products, the AVCP method nor the manufacturing conditions in the plant are modified significantly, unless suspended or withdrawn by the notified product certification body.

Detailed information about the scope of the product is given in the annex to this certificate.

Ljubljana, 4. 6. 2024

Authorised signatory of the Certification body:  
mag. Egon Milost, univ.dipl.inž.grad.





ZAG-001-318-2017      The certificate has a total of 3 pages      Certificate No. 1404 – CPR – 3738, issue 1

# Additional performances

PROGET multipurpose doors - concerned norm EN 14351-1:2006+A2:2016



PROGET  
multipurpose



| PROGET multipurpose door<br><br>Certificate CE:<br>1404 - CPR -3738<br> |   | Angular frame | Embracing frame | Tunnel frame | Combo with CR rebate gasket and door closer for C5 version |            | Combo with CR rebate gasket, drop-down seal and door closer for C5 version |             |
|--|---|---------------|-----------------|--------------|--|------------|--|-------------|
|  |   |               |                 |              | CE   | CE C5      | CE Sa/SF   | CE Sa/SF C5 |
| Without window<br>  | <b>EN 16034:2014</b>                    |               |                 |              |  |            |  |             |
|  | Fire resistance                         | ✓             | ✓               | ✓            | N.P.D.   | N.P.D.     | N.P.D.   | N.P.D.      |
|  | Smoke control                           | ✓             | ✓               | ✓            | N.P.D.   | N.P.D.     | Sa   | Sa          |
|  | Self-closing                            | ✓             | ✓               | ✓            | C  | C          | C  | C           |
|  | Durability of self-closing              |               |                 |              |  |            |  |             |
|  | - against degradation                   | ✓             | ✓               | ✓            | 0  | 5          | 0  | 5           |
|  | <b>EN 14351-1:2006+A2:2016</b>          |               |                 |              |  |            |  |             |
|  | Air permeability                        | ✓             | ✓               | ✓            | N.P.D.   | N.P.D.     | 2  | 2           |
|  | Water tightness                         | ✓             | ✓               | ✓            | N.P.D.   | N.P.D.     | 1A   | 1A          |
|  | Wind load resistance                    |               |                 |              |  |            |  |             |
|  | - door with FM ≤ 1140x2150              | ✓             | ✓               | ✓            | N.P.D.   | N.P.D.     | C1   | C1          |
|  | - door with FM > 1140x2150              | ✓             | ✓               | ✓            | N.P.D.   | N.P.D.     | N.P.D.   | N.P.D.      |
|  | Load-bearing capacity of safety devices | ✓             | ✓               | ✓            | Exceeds  | Exceeds    | Exceeds  | Exceeds     |
|  | Acoustic performance                    | ✓             | ✓               | ✓            | N.P.D.   | N.P.D.     | N.P.D.   | N.P.D.      |
|  | Thermal transmittance                   | ✓             |                 |              | 1,30 W/m²K   | 1,30 W/m²K | 1,30 W/m²K   | 1,30 W/m²K  |
|  | Thermal transmittance                   |               | ✓               |              | 1,70 W/m²K   | 1,70 W/m²K | 1,70 W/m²K   | 1,70 W/m²K  |
| Thermal transmittance  |   |               | ✓               | 1,70 W/m²K   | 1,70 W/m²K   | 1,70 W/m²K | 1,70 W/m²K   |             |
| With window<br>300x400<br>  | <b>EN 16034:2014</b>                    |               |                 |              |  |            |  |             |
|  | Fire resistance                         | ✓             | ✓               | ✓            | N.P.D.   | N.P.D.     | N.P.D.   | N.P.D.      |
|  | Smoke control                           | ✓             | ✓               | ✓            | N.P.D.   | N.P.D.     | Sa   | Sa          |
|  | Self-closing                            | ✓             | ✓               | ✓            | C  | C          | C  | C           |
|  | Durability of self-closing              |               |                 |              |  |            |  |             |
|  | - against degradation                   | ✓             | ✓               | ✓            | 0  | 5          | 0  | 5           |
|  | <b>EN 14351-1:2006+A2:2016</b>          |               |                 |              |  |            |  |             |
|  | Air permeability                        | ✓             | ✓               | ✓            | N.P.D.   | N.P.D.     | 2  | 2           |
|  | Water tightness                         | ✓             | ✓               | ✓            | N.P.D.   | N.P.D.     | 1A   | 1A          |
|  | Wind load resistance                    |               |                 |              |  |            |  |             |
|  | - door with FM ≤ 1140x2150              | ✓             | ✓               | ✓            | N.P.D.   | N.P.D.     | C1   | C1          |
|  | - door with FM > 1140x2150              | ✓             | ✓               | ✓            | N.P.D.   | N.P.D.     | N.P.D.   | N.P.D.      |
|  | Load-bearing capacity of safety devices | ✓             | ✓               | ✓            | Exceeds  | Exceeds    | Exceeds  | Exceeds     |
|  | Acoustic performance                    | ✓             | ✓               | ✓            | N.P.D.   | N.P.D.     | N.P.D.   | N.P.D.      |
|  | Thermal transmittance                   | ✓             |                 |              | 1,40 W/m²K   | 1,40 W/m²K | 1,50 W/m²K   | 1,50 W/m²K  |
|  | Thermal transmittance                   |               | ✓               |              | 1,90 W/m²K   | 1,90 W/m²K | 1,90 W/m²K   | 1,90 W/m²K  |
| Thermal transmittance  |   |               | ✓               | 1,90 W/m²K   | 1,90 W/m²K   | 1,90 W/m²K | 1,90 W/m²K   |             |

# Additional performances

PROGET multipurpose doors - concerned norm EN 14351-1:2006+A2:2016



PROGET  
multipurpose

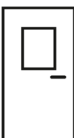

| <b>PROGET multipurpose door</b><br><br>Certificate CE: <br>1404 - CPR - 3738 |   | Angular frame | Embracing frame. | Tunnel frame | Combo with CR rebate gasket, drop-down seal and door closer for C5 version |                                 |
|---|---|---------------|------------------|--------------|--|---------------------------------|
|   |   |               |                  |              | CE S200/GS<br>CE S200/GSV  | CE S200/GS C5<br>CE S200/GSV C5 |
| <b>Without window</b><br><br>  | <b>EN 16034:2014</b>                    |               |                  |              |  |                                 |
|   | Fire resistance                         | ✓             | ✓                | ✓            | N.P.D.   | N.P.D.                          |
|   | Smoke control                           | ✓             | ✓                | ✓            | S200   | S200                            |
|   | Self-closing                            | ✓             | ✓                | ✓            | C  | C                               |
|   | Durability of self-closing              |               |                  |              |  |                                 |
|   | - against degradation                   | ✓             | ✓                | ✓            | 0  | 5                               |
|   | <b>EN 14351-1:2006+A2:2016</b>          |               |                  |              |  |                                 |
|   | Air permeability                        | ✓             | ✓                | ✓            | 2  | 2                               |
|   | Water tightness                         | ✓             | ✓                | ✓            | N.P.D.   | N.P.D.                          |
|   | Wind load resistance                    | ✓             | ✓                | ✓            | N.P.D.   | N.P.D.                          |
|   | Load-bearing capacity of safety devices | ✓             | ✓                | ✓            | Exceeds  | Exceeds                         |
|   | Acoustic performance                    |               |                  |              |  |                                 |
|   | - door with FM 800-1100 x 2000-2250     | ✓             | ✓                | ✓            | 33 dB  | 33 dB                           |
|   | - door with FM 1101-1340 x 2000-2250    | ✓             | ✓                | ✓            | 32 dB  | 32 dB                           |
|   | - door with FM 800-1340 x 2251-2670     | ✓             | ✓                | ✓            | 32 dB  | 32 dB                           |
|   | Thermal transmittance                   | ✓             |                  |              | 1,30 W/m²K   | 1,30 W/m²K                      |
| Thermal transmittance   |   | ✓             |                  | 1,70 W/m²K   | 1,70 W/m²K   |                                 |
| Thermal transmittance   |   |               | ✓                | 1,70 W/m²K   | 1,70 W/m²K   |                                 |
| <b>With window<br/>300x400</b><br><br>                                     | <b>EN 16034:2014</b>                    |               |                  |              |  |                                 |
|   | Fire resistance                         | ✓             | ✓                | ✓            | N.P.D.   | N.P.D.                          |
|   | Smoke control                           | ✓             | ✓                | ✓            | S200   | S200                            |
|   | Self-closing                            | ✓             | ✓                | ✓            | C  | C                               |
|   | Durability of self-closing              |               |                  |              |  |                                 |
|   | - against degradation                   | ✓             | ✓                | ✓            | 0  | 5                               |
|   | <b>EN 14351-1:2006+A2:2016</b>          |               |                  |              |  |                                 |
|   | Air permeability                        | ✓             | ✓                | ✓            | 2  | 2                               |
|   | Water tightness                         | ✓             | ✓                | ✓            | N.P.D.   | N.P.D.                          |
|   | Wind load resistance                    | ✓             | ✓                | ✓            | N.P.D.   | N.P.D.                          |
|   | Load-bearing capacity of safety devices | ✓             | ✓                | ✓            | Exceeds  | Exceeds                         |
|   | Acoustic performance                    |               |                  |              |  |                                 |
|   | - door with FM 800-1100 x 2000-2250     | ✓             | ✓                | ✓            | 32 dB  | 32 dB                           |
|   | - door with FM 1101-1340 x 2000-2250    | ✓             | ✓                | ✓            | 31 dB  | 31 dB                           |
|   | - door with FM 800-1340 x 2251-2670     | ✓             | ✓                | ✓            | 31 dB  | 31 dB                           |
|   | Thermal transmittance                   | ✓             |                  |              | 1,50 W/m²K   | 1,50 W/m²K                      |
| Thermal transmittance   |   | ✓             |                  | 1,90 W/m²K   | 1,90 W/m²K   |                                 |
| Thermal transmittance   |   |               | ✓                | 1,90 W/m²K   | 1,90 W/m²K   |                                 |

# Additional performances

PROGET multipurpose doors - concerned norm EN 14351-1:2006+A2:2016



PROGET  
multipurpose

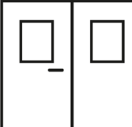
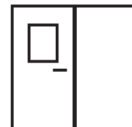

| PROGET multipurpose door  |   | Angular frame | Embracing frame. | Tunnel frame            | Combo with CR rebate gasket and door closer for C5 version |                         | Combo with CR rebate gasket, drop-down seal and door closer for C5 version |                         |
|---|---|---------------|------------------|-------------------------|--|-------------------------|--|-------------------------|
|   |   |               |                  |                         | CE   | CE C5                   | CE Sa/SF   | CE Sa/SF C5             |
| Certificate CE:<br>1404 - CPR -3738    |   |               |                  |                         |  |                         |  |                         |
| <b>With window</b><br>   | <b>EN 16034:2014</b>                          |               |                  |                         |  |                         |  |                         |
|   | Smoke control                                 | ✓             | ✓                | ✓                       | N.P.D.   | N.P.D.                  | Sa   | Sa                      |
|   | Self-closing                                  | ✓             | ✓                | ✓                       | C  | C                       | C  | C                       |
|   | Durability of self-closing                    |               |                  |                         |  |                         |  |                         |
|   | - against degradation                         | ✓             | ✓                | ✓                       | 0  | 5                       | 0  | 5                       |
|   | <b>EN 14351-1:2006+A2:2016</b>                |               |                  |                         |  |                         |  |                         |
|   | Air permeability                              | ✓             | ✓                | ✓                       | N.P.D.   | N.P.D.                  | 3  | 3                       |
|   | Water tightness                               | ✓             | ✓                | ✓                       | N.P.D.   | N.P.D.                  | 2A-4B  | 2A-4B                   |
|   | Wind load resistance                          |               |                  |                         |  |                         |  |                         |
|   | - door with FM ≤ 2300x2150                    | ✓             | ✓                | ✓                       | N.P.D.   | N.P.D.                  | C1   | C1                      |
|   | Load-bearing capacity of safety devices       | ✓             | ✓                | ✓                       | Exceeds  | Exceeds                 | Exceeds  | Exceeds                 |
|   | Acoustic performance                          | ✓             | ✓                | ✓                       | N.P.D.   | N.P.D.                  | N.P.D.   | N.P.D.                  |
|   | Thermal transmittance FM ≤ 3,6 m <sup>2</sup> | ✓             |                  |                         | 1,70 W/m <sup>2</sup> K                                    | 1,70 W/m <sup>2</sup> K | 1,70 W/m <sup>2</sup> K  | 1,70 W/m <sup>2</sup> K |
|   | Thermal transmittance FM > 3,6 m <sup>2</sup> | ✓             |                  |                         | 1,40 W/m <sup>2</sup> K                                    | 1,40 W/m <sup>2</sup> K | 1,40 W/m <sup>2</sup> K  | 1,40 W/m <sup>2</sup> K |
|   | Thermal transmittance FM ≤ 3,6 m <sup>2</sup> |               | ✓                |                         | 1,90 W/m <sup>2</sup> K                                    | 1,90 W/m <sup>2</sup> K | 1,90 W/m <sup>2</sup> K  | 1,90 W/m <sup>2</sup> K |
|   | Thermal transmittance FM > 3,6 m <sup>2</sup> |               | ✓                |                         | 1,50 W/m <sup>2</sup> K                                    | 1,50 W/m <sup>2</sup> K | 1,50 W/m <sup>2</sup> K  | 1,50 W/m <sup>2</sup> K |
| Thermal transmittance FM ≤ 3,6 m <sup>2</sup>   |   |               | ✓                | 1,90 W/m <sup>2</sup> K | 1,90 W/m <sup>2</sup> K                                    | 1,90 W/m <sup>2</sup> K | 1,90 W/m <sup>2</sup> K  |                         |
| Thermal transmittance FM > 3,6 m <sup>2</sup>   |   |               | ✓                | 1,50 W/m <sup>2</sup> K | 1,50 W/m <sup>2</sup> K                                    | 1,50 W/m <sup>2</sup> K | 1,50 W/m <sup>2</sup> K  |                         |
| <b>Without window 300x400</b><br><br> | <b>EN 16034:2014</b>                          |               |                  |                         |  |                         |  |                         |
|   | Smoke control                                 | ✓             | ✓                | ✓                       | N.P.D.   | N.P.D.                  | Sa   | Sa                      |
|   | Self-closing                                  | ✓             | ✓                | ✓                       | C  | C                       | C  | C                       |
|   | Durability of self-closing                    |               |                  |                         |  |                         |  |                         |
|   | - against degradation                         | ✓             | ✓                | ✓                       | 0  | 5                       | 0  | 5                       |
|   | <b>EN 14351-1:2006+A2:2016</b>                |               |                  |                         |  |                         |  |                         |
|   | Air permeability                              | ✓             | ✓                | ✓                       | N.P.D.   | N.P.D.                  | 3  | 3                       |
|   | Water tightness                               | ✓             | ✓                | ✓                       | N.P.D.   | N.P.D.                  | 2A-4B  | 2A-4B                   |
|   | Wind load resistance                          |               |                  |                         |  |                         |  |                         |
|   | - door with FM ≤ 2300x2150                    | ✓             | ✓                | ✓                       | N.P.D.   | N.P.D.                  | C1   | C1                      |
|   | Load-bearing capacity of safety devices       | ✓             | ✓                | ✓                       | Exceeds  | Exceeds                 | Exceeds  | Exceeds                 |
|   | Acoustic performance                          | ✓             | ✓                | ✓                       | N.P.D.   | N.P.D.                  | N.P.D.   | N.P.D.                  |
|   | Thermal transmittance FM ≤ 3,6 m <sup>2</sup> | ✓             |                  |                         | 2,10 W/m <sup>2</sup> K                                    | 2,10 W/m <sup>2</sup> K | 2,10 W/m <sup>2</sup> K  | 2,10 W/m <sup>2</sup> K |
|   | Thermal transmittance FM > 3,6 m <sup>2</sup> | ✓             |                  |                         | 1,90 W/m <sup>2</sup> K                                    | 1,90 W/m <sup>2</sup> K | 1,90 W/m <sup>2</sup> K  | 1,90 W/m <sup>2</sup> K |
|   | Thermal transmittance FM ≤ 3,6 m <sup>2</sup> |               | ✓                |                         | 2,30 W/m <sup>2</sup> K                                    | 2,30 W/m <sup>2</sup> K | 2,30 W/m <sup>2</sup> K  | 2,30 W/m <sup>2</sup> K |
|   | Thermal transmittance FM > 3,6 m <sup>2</sup> |               | ✓                |                         | 2,00 W/m <sup>2</sup> K                                    | 2,00 W/m <sup>2</sup> K | 2,00 W/m <sup>2</sup> K  | 2,00 W/m <sup>2</sup> K |
| Thermal transmittance FM ≤ 3,6 m <sup>2</sup>   |   |               | ✓                | 2,30 W/m <sup>2</sup> K | 2,30 W/m <sup>2</sup> K                                    | 2,30 W/m <sup>2</sup> K | 2,30 W/m <sup>2</sup> K  |                         |
| Thermal transmittance FM > 3,6 m <sup>2</sup>   |   |               | ✓                | 2,00 W/m <sup>2</sup> K | 2,00 W/m <sup>2</sup> K                                    | 2,00 W/m <sup>2</sup> K | 2,00 W/m <sup>2</sup> K  |                         |

# Additional performances

PROGET multipurpose doors - concerned norm EN 14351-1:2006+A2:2016

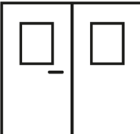
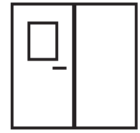

PROGET  
multipurpose

| PROGET multipurpose door   |   | Angular frame | Embracing frame. | Tunnel frame            | Combo with CR rebate gasket, drop-down seal and door closer for C5 version |                                 |
|--|---|---------------|------------------|-------------------------|--|---------------------------------|
|  |   |               |                  |                         | CE S200/GS<br>CE S200/GSV  | CE S200/GS C5<br>CE S200/GSV C5 |
| Certificate CE:<br>1404 - CPR -3738   |   |               |                  |                         |  |                                 |
| <b>Without window</b><br>   | <b>EN 16034:2014</b>                          |               |                  |                         |  |                                 |
|  | Smoke control                                 | ✓             | ✓                | ✓                       | S200   | S200                            |
|  | Self-closing                                  | ✓             | ✓                | ✓                       | C  | C                               |
|  | Durability of self-closing                    |               |                  |                         |  |                                 |
|  | - against degradation                         | ✓             | ✓                | ✓                       | 0  | 5                               |
|  | <b>EN 14351-1:2006+A2:2016</b>                |               |                  |                         |  |                                 |
|  | Air permeability                              | ✓             | ✓                | ✓                       | 3  | 3                               |
|  | Water tightness                               | ✓             | ✓                | ✓                       | N.P.D.   | N.P.D.                          |
|  | Wind load resistance                          | ✓             | ✓                | ✓                       | N.P.D.   | N.P.D.                          |
|  | Load-bearing capacity of safety devices       | ✓             | ✓                | ✓                       | N.P.D.   | N.P.D.                          |
|  | Acoustic performance                          |               |                  |                         |  |                                 |
|  | - FM min 1000 (L1/l2 max 799) x 2000 - 2670   | ✓             | ✓                | ✓                       | 30 dB  | 30 dB                           |
|  | - leaf of L1/L2 800-1100 x 2000-2250          | ✓             | ✓                | ✓                       | 33 dB  | 33 dB                           |
|  | - leaf of L1/L2 1101-1330 x 2000-2250         | ✓             | ✓                | ✓                       | 32 dB  | 32 dB                           |
|  | - leaf of L1/L2 800-1330 x 2251-2670          | ✓             | ✓                | ✓                       | 32 dB  | 32 dB                           |
|  | Thermal transmittance FM ≤ 3,6 m <sup>2</sup> | ✓             |                  |                         | 1,70 W/m <sup>2</sup> K  | 1,70 W/m <sup>2</sup> K         |
|  | Thermal transmittance FM > 3,6 m <sup>2</sup> | ✓             |                  |                         | 1,40 W/m <sup>2</sup> K  | 1,40 W/m <sup>2</sup> K         |
|  | Thermal transmittance FM ≤ 3,6 m <sup>2</sup> |               | ✓                |                         | 1,90 W/m <sup>2</sup> K  | 1,90 W/m <sup>2</sup> K         |
|  | Thermal transmittance FM > 3,6 m <sup>2</sup> |               | ✓                |                         | 1,50 W/m <sup>2</sup> K  | 1,50 W/m <sup>2</sup> K         |
| Thermal transmittance FM ≤ 3,6 m <sup>2</sup>  |   |               | ✓                | 1,90 W/m <sup>2</sup> K | 1,90 W/m <sup>2</sup> K  |                                 |
| Thermal transmittance FM > 3,6 m <sup>2</sup>  |   |               | ✓                | 1,50 W/m <sup>2</sup> K | 1,50 W/m <sup>2</sup> K  |                                 |
| <b>With window<br/>300x400</b><br><br> | <b>EN 16034:2014</b>                          |               |                  |                         |  |                                 |
|  | Smoke control                                 | ✓             | ✓                | ✓                       | S200   | S200                            |
|  | Self-closing                                  | ✓             | ✓                | ✓                       | C  | C                               |
|  | Durability of self-closing                    |               |                  |                         |  |                                 |
|  | - against degradation                         | ✓             | ✓                | ✓                       | 0  | 5                               |
|  | <b>EN 14351-1:2006+A2:2016</b>                |               |                  |                         |  |                                 |
|  | Air permeability                              | ✓             | ✓                | ✓                       | 3  | 3                               |
|  | Water tightness                               | ✓             | ✓                | ✓                       | N.P.D.   | N.P.D.                          |
|  | Wind load resistance                          | ✓             | ✓                | ✓                       | N.P.D.   | N.P.D.                          |
|  | Load-bearing capacity of safety devices       | ✓             | ✓                | ✓                       | N.P.D.   | N.P.D.                          |
|  | Acoustic performance                          |               |                  |                         |  |                                 |
|  | - FM min 1000 (L1/l2 max 799) x 2000 - 2670   | ✓             | ✓                | ✓                       | 29 dB  | 29 dB                           |
|  | - leaf of L1/L2 800-1100 x 2000-2250          | ✓             | ✓                | ✓                       | 32 dB  | 32 dB                           |
|  | - leaf of L1/L2 1101-1330 x 2000-2250         | ✓             | ✓                | ✓                       | 31 dB  | 31 dB                           |
|  | - leaf of L1/L2 800-1330 x 2251-2670          | ✓             | ✓                | ✓                       | 31 dB  | 31 dB                           |
|  | Thermal transmittance FM ≤ 3,6 m <sup>2</sup> | ✓             |                  |                         | 2,10 W/m <sup>2</sup> K  | 2,10 W/m <sup>2</sup> K         |
|  | Thermal transmittance FM > 3,6 m <sup>2</sup> | ✓             |                  |                         | 1,90 W/m <sup>2</sup> K  | 1,90 W/m <sup>2</sup> K         |
|  | Thermal transmittance FM ≤ 3,6 m <sup>2</sup> |               | ✓                |                         | 2,30 W/m <sup>2</sup> K  | 2,30 W/m <sup>2</sup> K         |
|  | Thermal transmittance FM > 3,6 m <sup>2</sup> |               | ✓                |                         | 2,00 W/m <sup>2</sup> K  | 2,00 W/m <sup>2</sup> K         |
| Thermal transmittance FM ≤ 3,6 m <sup>2</sup>  |   |               | ✓                | 2,30 W/m <sup>2</sup> K | 2,30 W/m <sup>2</sup> K  |                                 |
| Thermal transmittance FM > 3,6 m <sup>2</sup>  |   |               | ✓                | 2,00 W/m <sup>2</sup> K | 2,00 W/m <sup>2</sup> K  |                                 |

# Additional performances

PROGET multipurpose doors - concerned norm EN 14351-1:2006+A2:2016



| Essential requirements*  | EN 16034 | EN 14351 |
|--|----------|----------|
| Fire resistance  | YES      | NO       |
| Smoke control  | YES      | NO       |
| Self - closing   | YES      | NO       |
| Durability of performance  | YES      | NO       |
| Thermal insulation   | NO       | YES      |
| Air permeability   | NO       | YES      |
| Water tightness  | NO       | NO       |
| Acoustic performance   | NO       | NO       |
| Wind resistance  | NO       | NO       |
| Load-bearing capacity of safety devices  | NO       | YES      |
| Release/unlocking capability<br>(mandatory for doors installed on escape routes) | NO       | YES      |
| Minimum clear passage height: 2000 mm  | NO       | YES      |

## WARNING

For doors exposed to weather conditions and/or direct sunlight, the customer must take appropriate precautions to prevent long-term deterioration, in particular:

- Canopies or overhangs
- Outdoor paint with UV protection
- Use of light RAL colours to avoid overheating of metal sheets

\* Required under binding national provisions

# Additional performances

## PROGET multipurpose doors



PROGET multipurpose

### INTERNAL PEDESTRIAN DOORS



Classification report No. IFT 16-000122-PR03  
Test report No. IFT 12-001195-PR01

Pedestrian interior doors are not yet subject to CE marking as the relevant standard EN 14351-2 has not yet been harmonized. The performances listed in the standard can however be used as a reference for classifying the door for indoor uses, such as:

- air permeability according to EN 1026:2001
- thermal transmittance according to EN ISO 10077-1:2018 e EN ISO 10077-2:2018

PROGET multipurpose doors are also classified as Sa or S200 for smoke control according to EN 1634-3 (test method) and 13501-2 (classification).

The Proget price list lists the Combos which add these additional performances to the door.

#### ATTENTION

For the dimensional limits, minimum border measurements or production possibilities please refer to the specific pages of this brochure.

The values for the thermal transmittance  $W/m^2K$  shown in the table on the next page are given by the calculation according to the norm EN ISO 10077-1 done on samples of the dimensions 1,23x2,18 for areas  $\leq 3,6m^2$  and on samples of the dimensions 2,00x2,18 for areas  $> 3,6m^2$ .

All performance values indicated in the table are valid only in presence of the following accessories or enhancements:

- standard angular- for in the reveal application-embracing-frame
- isolation of the door frame with the filling of polyurethane foam
- installation of rubber seals along the entire perimeter of the door frame including the central rebate for double leaved doors
- sealing of the perimeter of the frame (side to push) with neutral silicone
- closing regulator RC2 for two-leaved doors (instead of RC/STD)
- presence of the automatic door sweep depending upon selected solution

In case of windows up to a maximum size of 400x600mm the differing performance value for the thermal transmittance needs to be asked, all other performance values remain unchanged.

For the acoustic isolation performance values, in case of asymmetric double leaved doors ( $L1 \neq L2$ ), select the minor Rw value of the two.

example 1: leaf without windows and  $H=2150$ ,  $L1=1000$ ,  $L2= 500$  select 30 dB;

example 2: leaf without windows and  $H=2150$ ,  $L1=1200$ ,  $L2=1000$  select 32 dB.

#### NOTE

For more details regarding the external installation, refer to the "Notices" section at the end of this brochure.

### SMOKE CONTROL ACCORDING TO EN 1634-3

This is the ability of a door set to reduce or eliminate the passage of smoke from one side of the door to the other. Two levels of smoke performance are defined.

Smoke control Sa: when the maximum dispersion value measured at room temperature and at a pressure of 25 Pascal is not greater than  $3 m^3/h$  per metre through the gap between the door leaf and the door frame excluding eventual losses through the floor threshold.

Smoke control S200: when the maximum dispersion value, measured at room temperature and 200 C and up to a pressure of 50 Pascal, is not greater than  $20 m^3/h$  for a single door or  $30 m^3/h$  for a two-door door.

The smoke tightness is verified with a specific technical test in accordance with UNI EN 1634-3, while the classification is provided by UNI EN 13501-2 according to the following criteria:

Sa considers only the seal at room temperature

S200 considers the seal at room temperature and at 200 C

| Evidence of Performance   |   | ift<br>ROSENHEIM   |
|---|---|--|
| Smoke leakage and self-closing of construction products and building elements                               |   |  |
| Classification Report<br>No.: 16-000122-PR03<br>(KB-C05-01-en-03)   |   |  |
| Client:   | NINZ s.p.a.<br>Corso Trento 2/A<br>38061 ALA<br>(Italy)   | Basis<br>EN 13501-2:2007+A1:2009<br>EN 13501-2:2016<br>EN 1265-1:2012<br>EN 1034-1:2014<br>EN 1034-3:2004AC:2008<br>EN 1191:2012<br>EN 10334:2014  |
| Prepared by the notified body:  | ift Rosenheim GmbH<br>Theodor-Giell-Straße 7-9<br>D-83026 Rosenheim                                     | Instructions for use<br>This classification report for smoke control and durability of self-closing devices defines the classification assigned to the building element according to its product name in conformity with the methods set out in EN 13501-2. This classification document does not represent type approval or certification of the product. |
| Notified body No.:  | 0757  | Validity<br>The data and results given relate solely to the tested and described specimens.  |
| Product name:   | PROGET MULTI REI / EI – 60/90/120<br>(nach den Angaben des Auftraggebers)                               | Notes on publication<br>This Ifit Guidance Sheet "Conditions and Guidance for the Use of Ifit Test Documents" applies.   |
| Classification:   | Classification of smoke control and self-closing according to EN 13501-2:2007+A1:2009 / EN 13501-2:2016 | Contents<br>The classification report consists of 13 pages and may only be used or reproduced in its entirety.<br>1 Introduction<br>2 Details of classified product<br>3 Test reports/extended application reports and test results in support of the classification<br>4 Classification and field of application<br>5 Limitations                         |
| Issue No.:  | 1   |  |
| <b>Smoke control doors and shutters</b>   |   |  |
| <b>Classification</b><br>$S_a / S_{200}$<br><b>C5</b>   |   |  |
|   |   |  |
| ift Rosenheim<br>07.05.2018<br>   |   |  |
| Dr. Gerhard Wackerbauer, Dipl. Phys.<br>Head of Testing Department<br>Smoke Control & Mechanical durability |   | Christine Schmaus, Dipl.-Ing. (FH)<br>Operating Product Officer<br>Building Components   |

ift Rosenheim GmbH | Kontakt: Tel. +49 8331 291-0 | Fax +49 8331 291-350 | www.ift-rosenheim.de | Prüfung und Kalibrierung – EN ISO/IEC 17025 | Institut für Bauteile – EN ISO/IEC 17025 | Zulassung Produkt – EN ISO/IEC 17093 | Zertifizierung Managementssysteme – EN ISO/IEC 17021 | Member Body 0757 | DABSS

# Additional performances

PROGET multipurpose doors



## INTERNAL PEDESTRIAN DOORS

Classification report No. IFT 16-000122-PR03

Test report No. IFT 12-001195-PR01

PROGET  
multipurpose

| FM L x H | standard frame<br>block frame in the reveal applic.<br>embracing frame | Combo Thermo/GS - Combo Thermo/GSV<br>Combo dB/GS - Combo dB/GSV<br>with rebate sealing CR<br>and automatic door sweep |  |   |  | Combo Thermo<br>Combo Sa<br>with rebate<br>sealing CR |  |   |                        |
|----------|--|--|--|---|--|---|--|---|------------------------|
|          |  | smoke control<br>according to<br>UNI EN 1634-3   | air permeability<br>according to<br>UNI EN 1026:2001 | thermal transmittance<br>according to<br>UNI EN 10077-1:2018<br>UNI EN 10077-2:2018 | acoustic performance<br>according to<br>UNI EN ISO 140-3 | smoke control<br>according to<br>UNI EN 1634-3        | air permeability<br>according to<br>UNI EN 1026:2001 | thermal transmittance<br>according to<br>UNI EN 10077-1:2018<br>UNI EN 10077-2:2018 |                        |
|          | without window   | ≤ 3,6 m <sup>2</sup>   | ✓  | S200  | classe 2   | 1,3 W/m <sup>2</sup> K                                |  | Sa  | 1,3 W/m <sup>2</sup> K |
|          |  | ≤ 3,6 m <sup>2</sup>   | ✓  | S200  | classe 2   | 1,7 W/m <sup>2</sup> K                                |  | Sa  | 1,7 W/m <sup>2</sup> K |
|          |  | ≤ 3,6 m <sup>2</sup>   | ✓  | S200  | classe 2   | 1,7 W/m <sup>2</sup> K                                |  | Sa  | 1,7 W/m <sup>2</sup> K |
|          |  | 800 - 1100 x 2000 - 2250   | ✓  | ✓   | ✓  |   |  | Rw = 33 dB  |                        |
|          |  | 1101 - 1340 x 2000 - 2250  | ✓  | ✓   | ✓  |   |  | Rw = 32 dB  |                        |
|          |  | 800 - 1340 x 2251 - 2670   | ✓  | ✓   | ✓  |   |  | Rw = 32 dB  |                        |
|          | with window 300x400  | ≤ 3,6 m <sup>2</sup>   | ✓  | S200  | classe 2   | 1,5 W/m <sup>2</sup> K                                |  | Sa  | 1,4 W/m <sup>2</sup> K |
|          |  | ≤ 3,6 m <sup>2</sup>   | ✓  | S200  | classe 2   | 1,9 W/m <sup>2</sup> K                                |  | Sa  | 1,9 W/m <sup>2</sup> K |
|          |  | ≤ 3,6 m <sup>2</sup>   | ✓  | S200  | classe 2   | 1,9 W/m <sup>2</sup> K                                |  | Sa  | 1,9 W/m <sup>2</sup> K |
|          |  | 800 - 1100 x 2000 - 2250   | ✓  | ✓   | ✓  |   |  | Rw = 32 dB  |                        |
|          |  | 1101 - 1340 x 2000 - 2250  | ✓  | ✓   | ✓  |   |  | Rw = 31 dB  |                        |
|          |  | 800 - 1340 x 2251 - 2670   | ✓  | ✓   | ✓  |   |  | Rw = 31 dB  |                        |
|          | without windows  | ≤ 3,6 m <sup>2</sup>   | ✓  | S200  | classe 3   | 1,7 W/m <sup>2</sup> K                                |  | Sa  |                        |
|          |  | > 3,6 m <sup>2</sup>   | ✓  | S200  | classe 3   | 1,4 W/m <sup>2</sup> K                                |  | Sa  | 1,4 W/m <sup>2</sup> K |
|          |  | ≤ 3,6 m <sup>2</sup>   | ✓  | S200  | classe 3   | 1,9 W/m <sup>2</sup> K                                |  | Sa  | 1,9 W/m <sup>2</sup> K |
|          |  | > 3,6 m <sup>2</sup>   | ✓  | S200  | classe 3   | 1,5 W/m <sup>2</sup> K                                |  | Sa  | 1,5 W/m <sup>2</sup> K |
|          |  | ≤ 3,6 m <sup>2</sup>   | ✓  | S200  | classe 3   | 1,9 W/m <sup>2</sup> K                                |  | Sa  | 1,9 W/m <sup>2</sup> K |
|          |  | > 3,6 m <sup>2</sup>   | ✓  | S200  | classe 3   | 1,5 W/m <sup>2</sup> K                                |  | Sa  | 1,5 W/m <sup>2</sup> K |
|          | with windows   | FM min 1000 (L1/L2 max 799) x 2000 - 2670  | ✓  | ✓   | ✓  |   |  | Rw = 30 dB  |                        |
|          |  | (L1 or L2) 800 - 1100 x 2000 - 2250  | ✓  | ✓   | ✓  |   |  | Rw = 33 dB  |                        |
|          |  | (L1 or L2) 1101 - 1330 x 2000 - 2250   | ✓  | ✓   | ✓  |   |  | Rw = 32 dB  |                        |
|          |  | (L1 or L2) 800 - 1330 x 2251 - 2670  | ✓  | ✓   | ✓  |   |  | Rw = 32 dB  |                        |
|          |  | ≤ 3,6 m <sup>2</sup>   | ✓  | S200  | classe 3   | 2,1 W/m <sup>2</sup> K                                |  | Sa  | 2,1 W/m <sup>2</sup> K |
|          | with windows 300x400   | > 3,6 m <sup>2</sup>   | ✓  | S200  | classe 3   | 1,9 W/m <sup>2</sup> K                                |  | Sa  | 1,9 W/m <sup>2</sup> K |
|          |  | ≤ 3,6 m <sup>2</sup>   | ✓  | S200  | classe 3   | 2,3 W/m <sup>2</sup> K                                |  | Sa  | 2,3 W/m <sup>2</sup> K |
|          |  | > 3,6 m <sup>2</sup>   | ✓  | S200  | classe 3   | 2,0 W/m <sup>2</sup> K                                |  | Sa  | 2,0 W/m <sup>2</sup> K |
|          |  | ≤ 3,6 m <sup>2</sup>   | ✓  | S200  | classe 3   | 2,3 W/m <sup>2</sup> K                                |  | Sa  | 2,3 W/m <sup>2</sup> K |
|          |  | > 3,6 m <sup>2</sup>   | ✓  | S200  | classe 3   | 2,0 W/m <sup>2</sup> K                                |  | Sa  | 2,0 W/m <sup>2</sup> K |
|          | with windows   | FM min 1000 (L1/L2 max 799) x 2000 - 2670  | ✓  | ✓   | ✓  |   |  | Rw = 29 dB  |                        |
|          |  | (L1 or L2) 800 - 1100 x 2000 - 2250  | ✓  | ✓   | ✓  |   |  | Rw = 32 dB  |                        |
|          |  | (L1 or L2) 1101 - 1330 x 2000 - 2250   | ✓  | ✓   | ✓  |   |  | Rw = 31 dB  |                        |
|          |  | (L1 or L2) 800 - 1330 x 2251 - 2670  | ✓  | ✓   | ✓  |   |  | Rw = 31 dB  |                        |

ATTENTION: air permeability and thermal transmittance performances are the same for Combo Thermo GS and GSV, Combo S200/GS, Combo S200/GSV, Combo dB/GS, Combo dB/GSV

### NOTE

These additional performances are not available for multipurpose doors type PROGET with: OVERHEAD PANEL, all types of aeration louvers, roller lock with G1X handle

# Door cross sections - Measurements

PROGET multipurpose doors



PROGET  
multipurpose

## One-leaved doors

Horizontal cross section

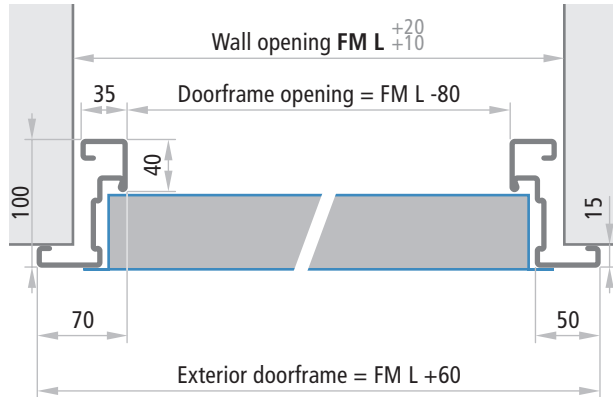

## Doors without lower threshold

Vertical cross section

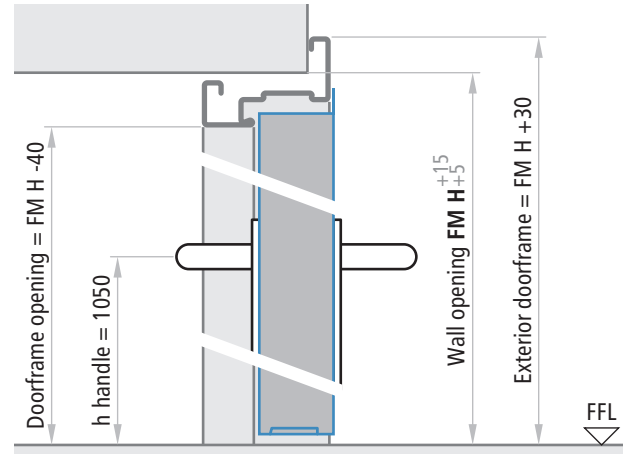

## Two-leaved doors

Horizontal cross section

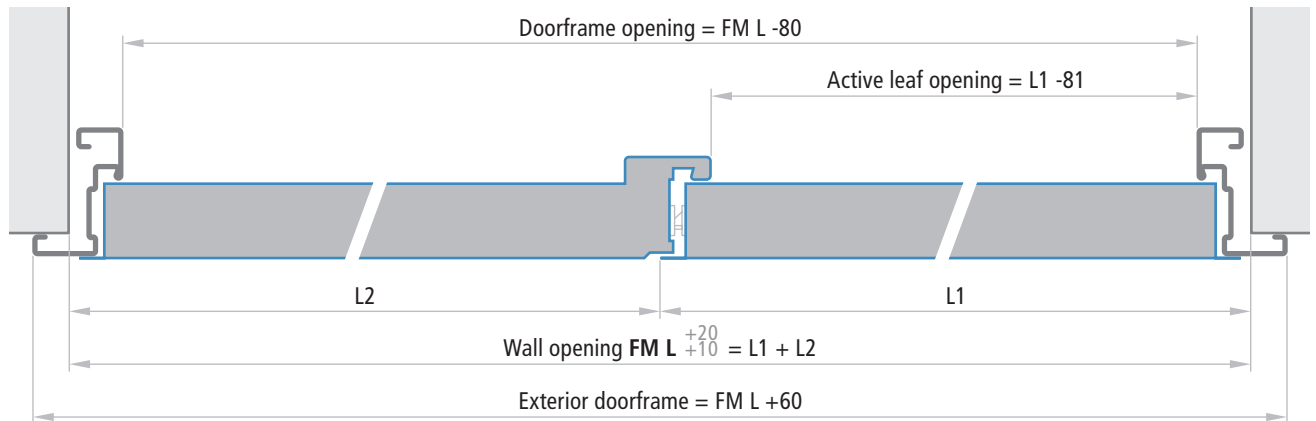

## One-leaved doors with frame on 4 sides and leaf with lower rebate

Vertical cross section

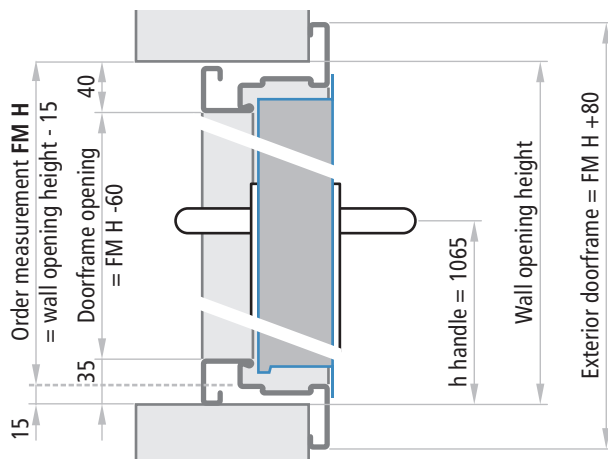

## One-leaved doors with frame on 4 sides and leaf without lower rebate

Vertical cross section

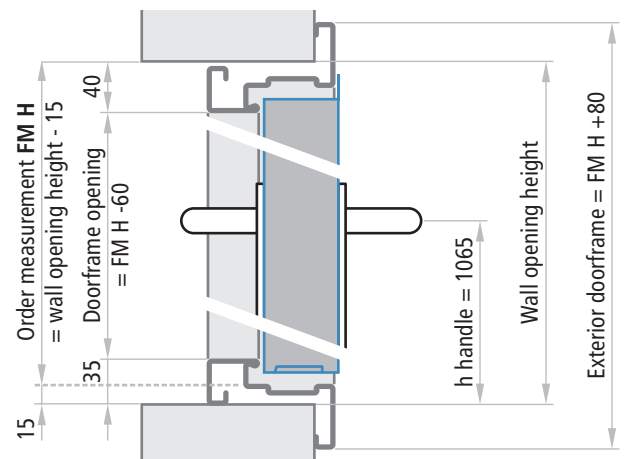

## Leaves thickness

|              |       |
|--------------|-------|
| MULTIPURPOSE | 60 mm |
|--------------|-------|

## NOTE

The tolerances  $FM L +20$ ,  $FM H +15$  of the indicated measurements make it easier to fill the gap between the wall and the doorframe with cement mortar.

For dry wall installation, the holes must be precise and greater tolerance ranges should not be employed.

# Installation methods

PROGET multipurpose doors



PROGET  
multipurpose

## INSTALLATION WITH ANCHORS FOR MORTAR FIXING

Standard installation method for Proget doors is with anchors for mortar fixing. Appropriate cuts for the anchors will need to be created in the walls (section 80 x 200 mm) or fixed with plugs. For fixing with screws the anchors should be used as spacers and fixed with expansion screws. For a perfect mechanical fit, the space between the doorframe and the masonry shall always be filled with concrete mortar or polyurethane foam; the filling with polyurethane foam is mandatory in case of external use with  $\text{C} \text{€}$  marking.



### One-leaved doors

FM L = from 500 to 1340 x FM H = from 800 to 1749

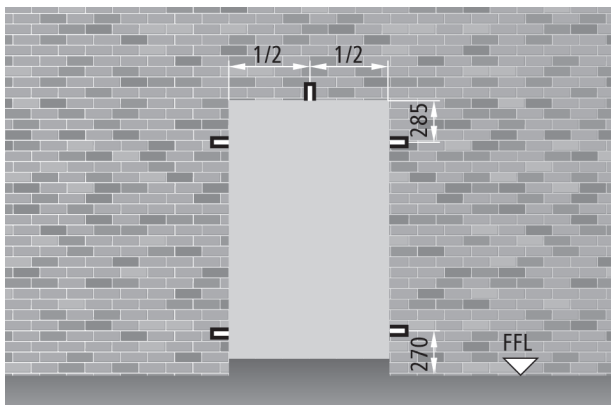

FM L = from 500 to 1035 x FM H = from 1750 to 2200

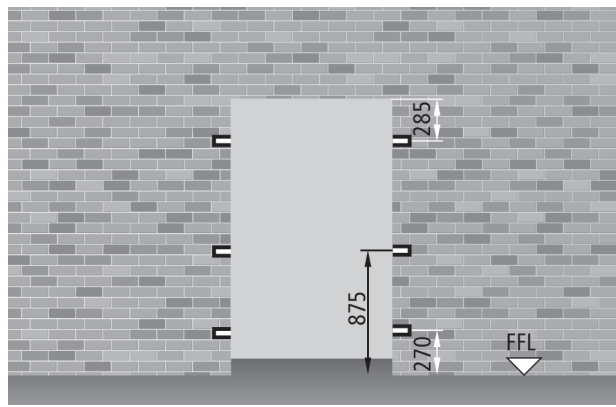

FM L greater than 1036 and/or FM H greater than 2200

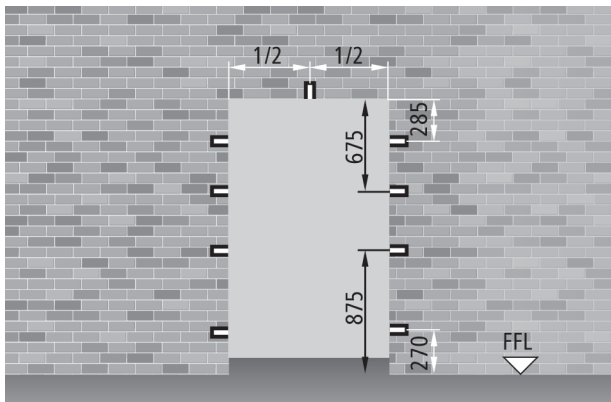

### NOTE

For proper installation, the cuts for the anchors should be 80 x 200 mm in size.

# Installation methods

PROGET multipurpose doors



PROGET  
multipurpose

## Two-leaved doors

FM L = from 850 to 2660 x FM H = from 800 to 1749

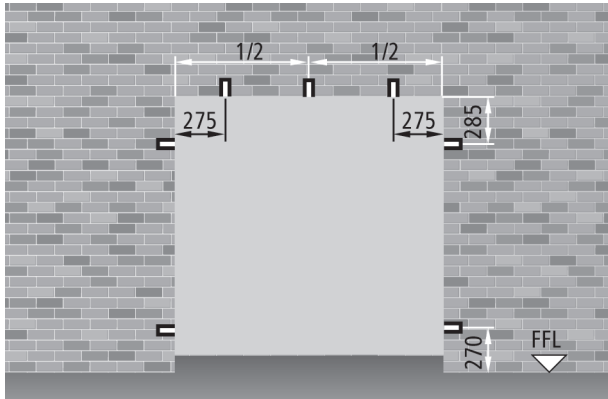

FM L = from 850 to 2070 x FM H = from 1750 to 2200

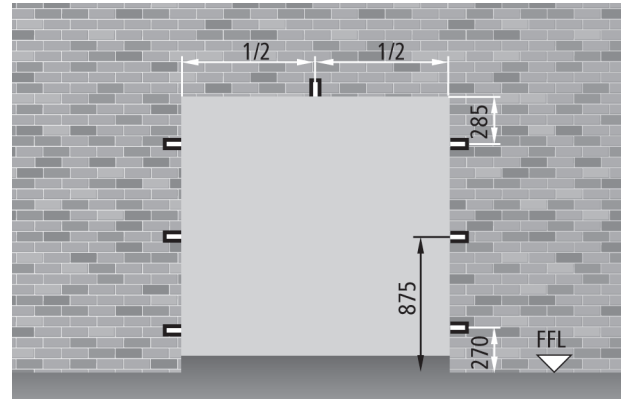

FM L greater than 2070 and/or FM H greater than 2200

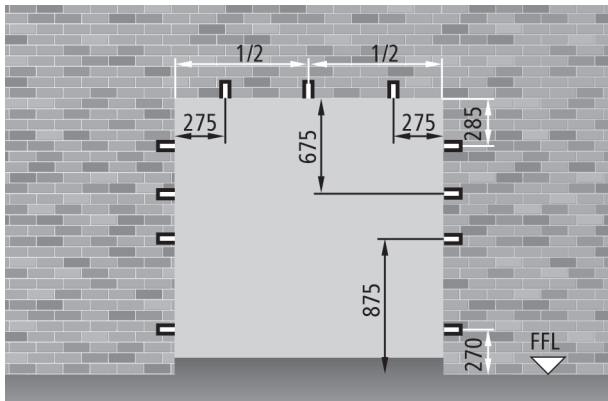

## INSTALLATION FOR EXPANSION SCREWS FIXING

Upon request, the Proget doors can be supplied with pre-drilled holes for the installation with expansion/wall screws. In this case, the doorframe will be supplied without anchors. For a perfect mechanical fit, the space between the doorframe and the masonry shall always be filled with concrete mortar or polyurethane foam; the filling with polyurethane foam is mandatory in case of external use with  $\text{C}\text{C}$  marking.



## WALL SCREWS

For direct wall installations or installation onto subframes, special expansion screws should be used without plugs. Please see the "door accessories" pages for more details.

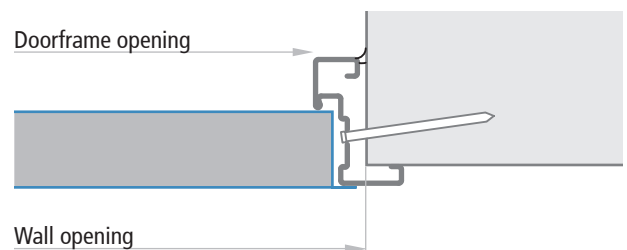

# Order measurements

PROGET multipurpose doors



## ORDER MEASUREMENTS

### Wall Opening

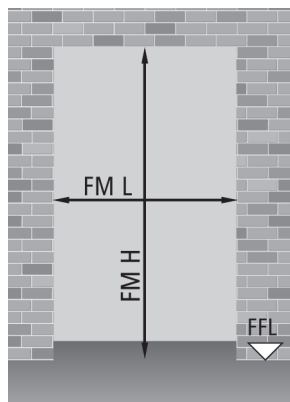

### Doorframe opening

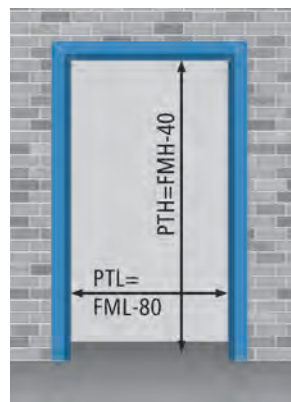

### In the reveal application opening

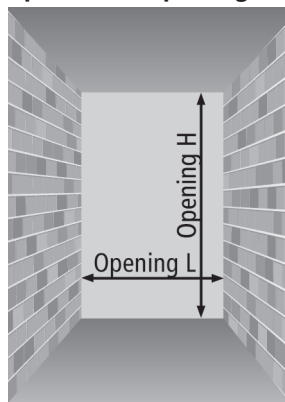

#### One-leaved doors

Opening L = FM L + 70  
Opening H = FM H + 35

#### Two-leaved doors

Opening L = FM L + 70  
Opening H = FM H + 35

#### NOTE

The wall openings to be created for in the reveal application, do not correspond to the order measurement and therefore should follow the above specifications.

### One-leaved door FM L x FM H

### PT L x PT H (doorframe opening)

| standard dimensions |   |                                  | frame on 3 sides |   |                                  | frame on 4 sides |   |                                  |
|---------------------|---|----------------------------------|------------------|---|----------------------------------|------------------|---|----------------------------------|
| 800                 | x | 2000 / 2050 / 2100 / 2150 / 2200 | 720              | x | 1960 / 2010 / 2060 / 2110 / 2160 | 720              | x | 1940 / 1990 / 2040 / 2090 / 2140 |
| 900                 | x | 2000 / 2050 / 2100 / 2150 / 2200 | 820              | x | 1960 / 2010 / 2060 / 2110 / 2160 | 820              | x | 1940 / 1990 / 2040 / 2090 / 2140 |
| 1000                | x | 2000 / 2050 / 2100 / 2150 / 2200 | 920              | x | 1960 / 2010 / 2060 / 2110 / 2160 | 920              | x | 1940 / 1990 / 2040 / 2090 / 2140 |
| 1100                | x | 2050 / 2100 / 2150 / 2200        | 1020             | x | 2010 / 2060 / 2110 / 2160        | 1020             | x | 1990 / 2040 / 2090 / 2140        |
| 1200                | x | 2050 / 2100 / 2150 / 2200        | 1120             | x | 2010 / 2060 / 2110 / 2160        | 1120             | x | 1940 / 1990 / 2040 / 2090 / 2140 |
| 1300                | x | 2000 / 2050 / 2100 / 2150 / 2200 | 1220             | x | 1960 / 2010 / 2060 / 2110 / 2160 | 1220             | x | 1990 / 2040 / 2090 / 2140        |
| 1340                | x | 2050 / 2100 / 2150 / 2200        | 1260             | x | 2010 / 2060 / 2110 / 2160        | 1260             | x | 1990 / 2040 / 2090 / 2140        |

#### non-standard dimensions

|                  |   |                   |                  |   |             |             |             |
|------------------|---|-------------------|------------------|---|-------------|-------------|-------------|
| from 500 to 1340 | x | from 1750 to 2670 | from 420 to 1260 | x | 1710 / 2630 | from 420 to | 1690 / 2610 |
|------------------|---|-------------------|------------------|---|-------------|-------------|-------------|

# Order measurements - Handle height

PROGET multipurpose doors



PROGET  
multipurpose

## Two-leaved doors FM L (L1+L2) x FM H

## PT L x PT H

| standard dimensions |               |   |                                  | doorframe opening |   |                                  |
|---------------------|---------------|---|----------------------------------|-------------------|---|----------------------------------|
| 1150                | ( 800 + 350)  | x | 2000 / 2050 / 2100 / 2150 / 2200 | 1070              | x | 1960 / 2010 / 2060 / 2110 / 2160 |
| 1200                | ( 800 + 400)  | x | 2000 / 2050 / 2100 / 2150 / 2200 | 1120              | x | 1960 / 2010 / 2060 / 2110 / 2160 |
| 1250                | ( 800 + 450)  | x | 2000 / 2050 / 2100 / 2150 / 2200 | 1170              | x | 1960 / 2010 / 2060 / 2110 / 2160 |
| 1250                | ( 900 + 350)  | x | 2000 / 2050 / 2100 / 2150 / 2200 | 1170              | x | 1960 / 2010 / 2060 / 2110 / 2160 |
| 1300                | ( 900 + 400)  | x | 2000 / 2050 / 2100 / 2150 / 2200 | 1220              | x | 1960 / 2010 / 2060 / 2110 / 2160 |
| 1350                | ( 900 + 450)  | x | 2000 / 2050 / 2100 / 2150 / 2200 | 1270              | x | 1960 / 2010 / 2060 / 2110 / 2160 |
| 1350                | (1000 + 350)  | x | 2000 / 2050 / 2100 / 2150 / 2200 | 1270              | x | 1960 / 2010 / 2060 / 2110 / 2160 |
| 1400                | (1000 + 400)  | x | 2000 / 2050 / 2100 / 2150 / 2200 | 1320              | x | 1960 / 2010 / 2060 / 2110 / 2160 |
| 1450                | (1000 + 450)  | x | 2000 / 2050 / 2100 / 2150 / 2200 | 1370              | x | 1960 / 2010 / 2060 / 2110 / 2160 |
| 1600                | ( 800 + 800)  | x | 2000 / 2050 / 2100 / 2150 / 2200 | 1520              | x | 1960 / 2010 / 2060 / 2110 / 2160 |
| 1700                | ( 900 + 800)  | x | 2000 / 2050 / 2100 / 2150 / 2200 | 1620              | x | 1960 / 2010 / 2060 / 2110 / 2160 |
| 1800                | ( 900 + 900)  | x | 2000 / 2050 / 2100 / 2150 / 2200 | 1720              | x | 1960 / 2010 / 2060 / 2110 / 2160 |
| 1800                | (1000 + 800)  | x | 2000 / 2050 / 2100 / 2150 / 2200 | 1720              | x | 1960 / 2010 / 2060 / 2110 / 2160 |
| 1900                | (1000 + 900)  | x | 2000 / 2050 / 2100 / 2150 / 2200 | 1820              | x | 1960 / 2010 / 2060 / 2110 / 2160 |
| 2000                | (1000 + 1000) | x | 2000 / 2050 / 2100 / 2150 / 2200 | 1920              | x | 1960 / 2010 / 2060 / 2110 / 2160 |

### non-standard dimensions

from 850 (500 + 350) to 2660 (1330 + 1330) x from 1750 to 2670 from 770 to 2580 x from 1710 to 2630

### NOTE

Doors leaves that are wider than they are tall are not permitted.

## HANDLE HEIGHT

### One-leaved door

$h = 1050$  (FM H  $\geq 1750$ )

Different heights available upon request only



### Two-leaved door

$h = 1050$  (FM H  $\geq 1750$ )

Different heights available upon request only



# Opening measurements - Overall dimensions

PROGET multipurpose doors



PROGET multipurpose

## OPENING MEASUREMENTS AND OVERALL DIMENSIONS WITH 90 DEGREE OPENING

### One-leaved doors with panic bar

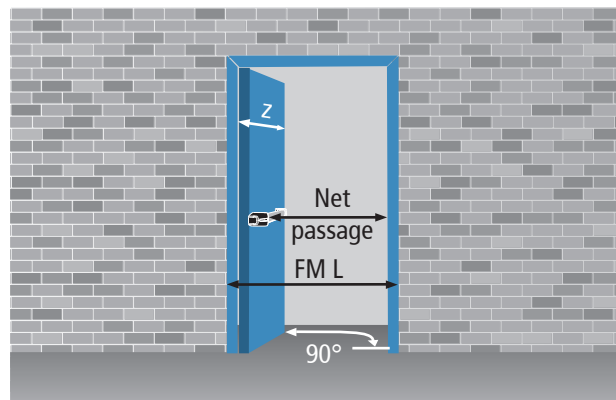

### Two-leaved doors with panic bars

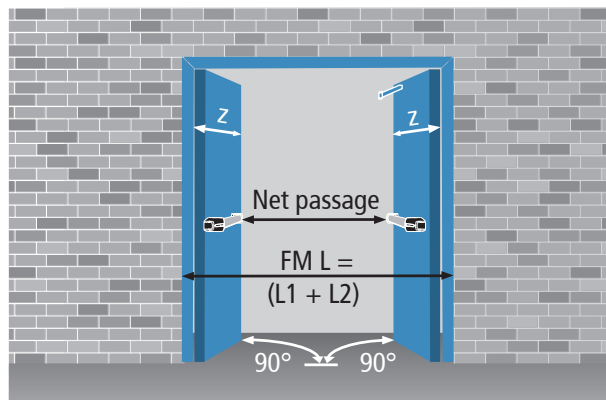

### Net passage calculation

| panic bar type                           | protrusion | one-leaved door | two-leaved door  |
|--|------------|-----------------|------------------|
| EXUS                                     | 125        | FM L - 245      | FM L - 410       |
| TWIST                                    | 100        | FM L - 220      | FM L - 360       |
| SLASH                                    | 75         | FM L - 195      | FM L - 310       |
| FAST TOUCH                               | 75         | FM L - 195      | FM L - 310       |
| without panic bar                        | -          | FM L - 120      | FML - 160        |
| z = leaf protrusion relative to the wall |            | FM L + 27       | L1 + 35, L2 + 75 |

## OVERALL DIMENSIONS WITH 180 DEGREE OPENING

### One-leaved door

$x = FM L - 7$

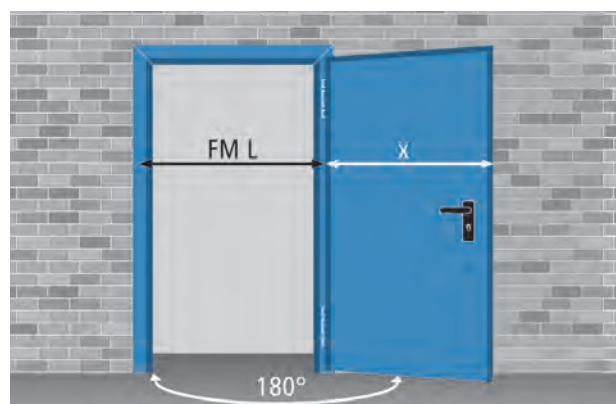

### Two-leaved door

$x = L1 + 1$     $y = L2 + 42$     $b = 130$

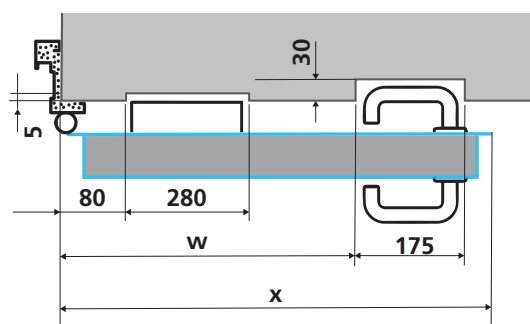
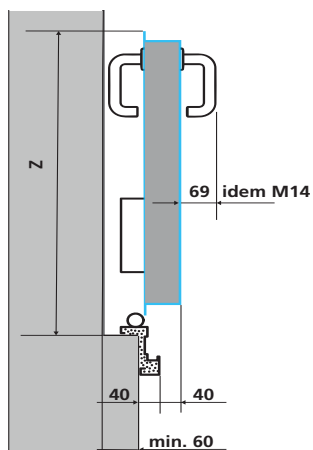
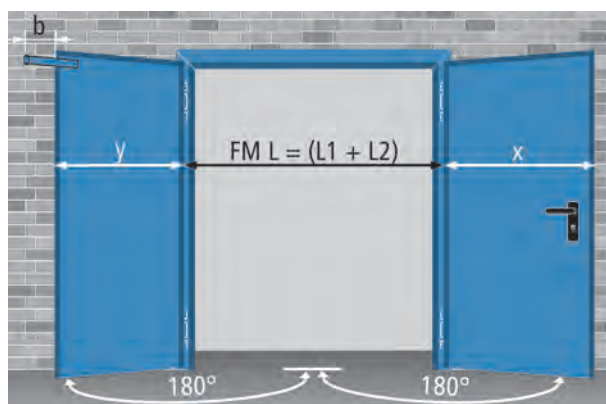

**“the ideal finish for every type of surrounding”**



# MORE THAN FIREDOORS

## Painting and NDD® decorations for metal doors

|                           |           |
|---------------------------|-----------|
| PAINTING                  | 122 - 123 |
| NDD® - NINZ DIGITAL DECOR | 124       |
| DECORATION GROUPS         | 125       |
| SPECIFICATIONS            | 126       |
| EXAMPLES                  | 127       |

**Painting**

This standard door is painted with thermoset powders, anti-scratch orange skin and semi-glossy finish (except for certain colors). The paint is particularly resistant and offers a pleasant finish for interior applications. Choose from a wide range of RAL colors.



**COLORS FOR INTERIOR USE  
WITHOUT PRICE SUPPLEMENT**

Paint for interior use (group 01) with epoxy-polyester powders.  
Standard color (without any specification): RAL 9010

Other RAL colors are available upon request (to be indicated in the order).

**COLORS FOR INTERIOR USE  
WITH PRICE SUPPLEMENT**

Paint for interior use (groups 02 and 03) available in a variety of RAL colors with epoxy-polyester powders. Doors must be protected from atmospheric agents. Sunlight fades the colors.

Distinct from other RAL colours, metallic tinted paints RAL 9006, RAL 9007 (group 3) and RAL 9006 E (group 04) present a finish with a wrinkled structure that requires pre-approval of a sample.

**Group 01 - standard color:      RAL colors upon request:**

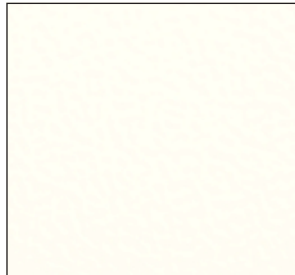
|  |          |          |               |               |
|--|----------|----------|---------------|---------------|
| RAL 9010<br> | RAL 1013 | RAL 5010 | RAL 7016      | RAL 7035      |
|  | RAL 9001 | RAL 7038 | RAL 7024      |               |
|  | RAL 1015 | RAL 9002 | NCS 4020-B50G | NCS 5020-B50G |

**Group 02:**

|          |          |          |          |          |
|----------|----------|----------|----------|----------|
| RAL 5024 | RAL 8011 | RAL 9011 | RAL 9018 | RAL 9016 |
|----------|----------|----------|----------|----------|

**Group 03:**

|          |          |          |          |           |           |
|----------|----------|----------|----------|-----------|-----------|
| RAL 1003 | RAL 3000 | RAL 3003 | RAL 3020 | RAL 6005  |           |
| RAL 7004 | RAL 7030 | RAL 7032 | RAL 7037 | RAL 7040  | RAL 7042  |
| RAL 7047 | RAL 8017 | RAL 8019 | RAL 9005 | RAL 9006* | RAL 9007* |

\*requires pre-approval of a sample.

## COLORS FOR EXTERIOR USE WITH PRICE SUPPLEMENT

Paint with UV protection (group 04) with polyester powders in various RAL colours.

| Group 04: |       |       |       |       |       |       |       |
|-----------|-------|-------|-------|-------|-------|-------|-------|
| RAL       | RAL   | RAL   | RAL   | RAL   | RAL   | RAL   | RAL   |
| 1013E     | 3000E | 5010E | 6005E | 7016E | 7024E | 7035E | 9002E |
|           |       |       |       |       |       |       |       |
| RAL       | RAL   | NCS   | NCS   |       |       |       |       |
| 9006E*    | 9010E | 4020E | 5020E |       |       |       |       |
|           |       |       |       |       |       |       |       |

\*requires pre-approval of a sample.

## COLORS ON REQUEST WITH PRICE SUPPLEMENT

Paint available for interior or with UV protection (group 05) with epoxy-polyester and polyester (respectively) powders in the requested RAL colours. Some special colors are not included, such as metallic, mica, smooth or wrinkled texture and other sample colours like Pantone, NCS, etc.

| Group 05:              |
|------------------------|
| Colors on request only |

## SPECIAL PAINTING ON REQUEST WITH PRICE SUPPLEMENT

### Bacterial proof painting

Paint available for interior or with UV protection (group 06) with epoxy-polyester and polyester with silver ions additives. On surface painted with this particular treatment, germs are hindered to take root and proliferate, offering good resistance to routine cleaning. Particularly suitable for use on doors intended for health care facilities, food industries, schools and child care, etc.

### Graffiti proof painting

Paint with UV protection (group 06) that allows, through a special solvent, to easily remove the graffiti. It provides long-lasting protection, allowing repeated cleanings without damaging the finish.

| Group 06:              |
|------------------------|
| Colors on request only |



## PRECAUTIONS

### Installation

In case of exterior installation of the doors, in addition to use special paints which are especially designed for this kind of application (see groups 04 and 05), in order to avoid any product degradation, it is important to:

- protect the doors from bad weather and water seeping in
- avoid direct sun rays and the subsequent warping of the door leaf, especially in case of darker colors

For more details, refer to the "Notices" section of this brochure.

### Cleaning

Water and neutral soap are recommended for the regular cleaning of our products. Do not use common cleaning products (see detergents) and/or other solvents. We shall not be held responsible for any problems that arise if these guidelines are not respected.

### Re-painting

For re-painting, use the following procedure:

- sand and carefully wipe away any dust from the surfaces
- apply a base coat of semi-gloss acrylic (we recommend the product ACRILFIN SL series 567 made by ELCROM - Italy + 20% by weight aliphatic hardener series E872003)
- repaint the surfaces with your choice of lacquers or paints

### Retouching

Upon request, the company Ninz also provides touch-up colors for the required RAL colour paint (nitro/synthetic) in 60 gr. handy bottle with brush cap or in 1,00 kg can.

**Ninz Digital Decor**  
NDD provides clients with an infinite number of graphic possibilities applicable to the surfaces of NINZ doors.



**DESCRIPTION**

NDD - Ninz Digital Decor decorative painting. Graphic illustrations are applied directly to the flat surfaces of the door leaf after it has been painted with a base coat of polymerized powders. Painting with high-resolution digital print using special ink jets. The application of an additional layer of transparent coating ensures optimal protection of the decorative paint. **Decorative NDD painting is available only for Univer and Proget doors.**

awarded with the  
**security&safety**  
award

NDD® - Ninz Digital Decor introduces style and design to metal door products. Ninz doors can be directly printed with either your company's logo or designs, materials and symbols selected from a wide variety of NDD®, or also with your preferred artwork or customized images. NDD® introduces innovations to doors as an architectural entity; introducing NDD® can create added value on socio-cultural, economic and emotional dimensions.

The [www.ninz.it](http://www.ninz.it) website illustrates an infinity of continuously updated decorations that have been categorized into eight groups for rapid review. The groups are listed on the next page.

**Laboratory testing executed on NDD® samples**

**result**

|  |  |
|--|--|
| 500 h exposure test in salt fog            | good performance, no sign of deterioration encountered                       |
| 500 h humidity resistance test             | good performance, no deterioration or loss of surface shine                  |
| 500 h UVA radiation resistance test        | good performance, no deterioration or loss of surface shine                  |
| Abrasion resistance test after 1000 cycles | the decoration was unaltered   |
| Solvent resistance test                    | good performance, no deterioration in the decoration or the background paint |

**ARTLINE** This group includes a wide selection of famous artworks drawn from ancient history up to the present day. These extraordinary designs endow the environment with a special atmosphere as an expression of style.

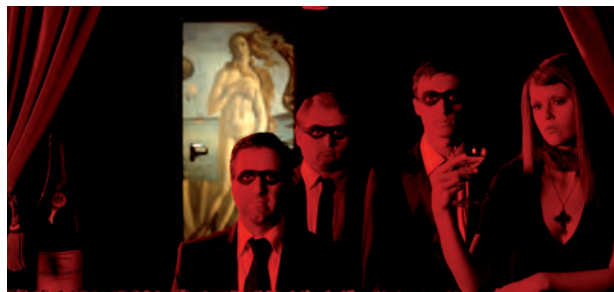

**WOOD** This set includes an endless variety of realistic imitations of classic, exotic, special and colored types of wood.



**FANTASY** NDD is a data bank of exclusive NINZ images and creations.



**STONES** This selection includes an endless variety of realistic imitations of marbles, granites and other stones.



**PATTERN** Contains an infinite number of NDD decorations and textures created on customer request and available and useable for a diverse variety of applications.

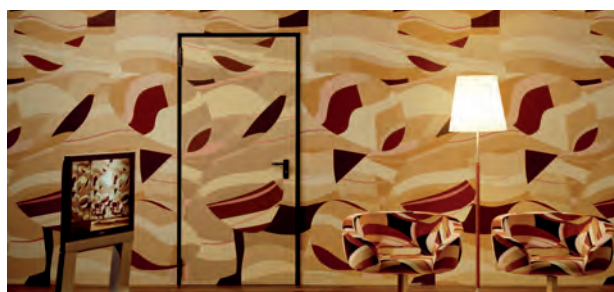

**PUBLICITY** Transforms Ninz doors into a publicity tool for the company and its products. Printing of the logo integrates the door into the company image. A variety of actual applications are reported here.



**PHOTOGRAPHS** This group contains original photos of country sides, objects, animals, environments, etc., with the appropriate foto resolution.



**SYMBOLS** Given the particular importance of this group, a special department has been created for workplace safety symbols, room description/labeling symbols, the simple numbering of rooms, etc.



## DECORATIONS FROM OUR DATABASE

Doors with decorative NDD painting are supplied with:

- doorframes in the proposed color
- door leaf rebate in the base color of the leaf itself
- hinges in the frame color
- accessories of the type and finishing according to the Ninz door price lists and brochures
- decoration covering the window frame and/or the central upright, require that these are covered with NDD decorated sheet metal

## SPECIAL DECORATIONS

New codes and pricing are required for customized decorations and decorations that employ colors not listed in this brochure. In such cases, customers may also be asked to indicate where logos and symbols should be positioned on the door leaf, via the following forms of support:

- PC-GENERATED FILE (logos, symbols, designs, etc.) in specialized "Illustrator" or "Freehand" format. Submit the file by e-mail or on a CD/DVD-ROM.
- DIAPOSITIVE with a 36 mm or 6 x 6 image of the picture uploaded to a PC using a scanner (professional scanner required). Submit the file (TIF, PDF or JPG format) in maximum resolution on CD/DVD-ROM.
- PHOTOGRAPHIC IMAGE made with a digital camera. Submit the file (TIF, PDF or JPG format) in maximum resolution on CD/DVD-ROM.

## UV PROTECTION

The exterior installation of NDD doors requires specific treatments for preventing the decorations from deteriorating over time. The cost supplement covers all door leaf surfaces except for the leaf rebate.

## FINISHING

When placing your order, you can choose the finish for your NDD decoration — specifically, whether to have it in a matte or glossy finish.

## WOODEN CRATE PACKAGING



The particularity and prestige of NDD decorations requires a special protection of the doors by packaging them in special wooden crates with an additional layer of external nylon wrapping. At the time of ordering, therefore, the additional cost for the wooden crate must be taken into consideration.



## MORE THAN FIREDOORS

## EXAMPLE APPLICATIONS IN TYPICAL SURROUNDINGS

Airports - Train stations



Museums – Historical buildings



Commercial businesses



Hospitals – Nursing homes



Sport centers – Stadiums



Parking lots



Logistic centers



Schools - Universities

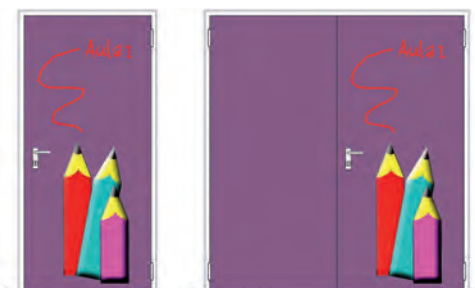

Hotels – Residences



Offices



**"quality accessories distinguish the door"**





## Optional accessories for MINZ doors

|  |           |
|--|-----------|
| HANDLES  | 130 - 133 |
| CYLINDERS  | 134 - 137 |
| DOOR CLOSERS, CLOSING REGULATORS                       | 138 - 141 |
| DOOR SWEEP, ROOFING - DRIP PROFILE - PROTECTIVE PLATES | 142 - 143 |
| WALL SCREWS - SUBFRAME                                 | 144       |
| MAC® ACCESS CONTROL, ELECTRIC HANDLES, SENSOR          | 145 - 148 |
| DOOR BLOCKING ELECTROMAGNET, COMMANDS                  | 149 - 150 |
| DOOR-HOLDING SYSTEMS                                   | 151 - 153 |



# Handles

Standard for REVER - UNIVER - PROGET doors

## BLACK PLASTIC HANDLES

By default Rever, Univer and Proget doors include safety levers coupled with long plates with cylinder holes. Each handle set includes a patent key insert, a 9 x 9mm square spindle, fastener screws and spacers.

### M1 HANDLE

The M1-type handles are supplied as standard for Univer and Proget doors and, on request, for all other types of NINZ doors.

M1 handles are fire rated consisting of a metal core inside the lever and a galvanized steel cover plate to protect the cylinder hole and have been certified in accordance with DIN 18273:1997-12.

The M1 handle package includes: a pair of black plastic lever with metal cores and galvanized steel installation plates, a pair of black plastic cover plates with patent-type cylinder hole adaptable for installation of Euro profile cylinders, a 125 mm long 9 x 9 square spindle, fastener screws and spacers. The package includes also the hexagonal key for setting of the hinges and fastening of the spring screw.



M1 plastic handle

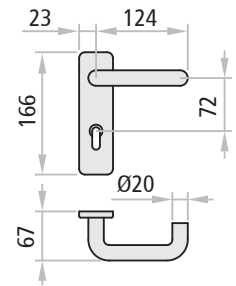

### M1R HANDLE

Rever doors are equipped with M1R-type handles.

The M1R handle package includes: a pair of black plastic lever handles, a pair of black plastic cover plates with patent-type cylinder holes adaptable for installation of Euro profile cylinders, a 125 mm long 9 x 9 square spindle, fastener screws and spacers.



M1R plastic handle

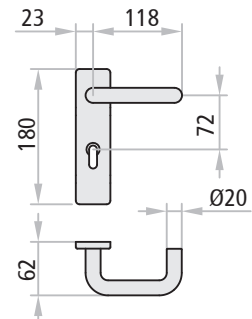

# Handles

For locks with an inter-axis distance of 72 mm



## COLORED HANDLES

On request, painted resin handles can be provided which match or provide better contrast with the base color of the door.

M1C and M2C handles are fire rated like the M1 handle, and have also been certified in accordance with DIN 18273:1997-12.

The M1C and M2C handles package consist of: one pair of lever handles (M1C) or the handle/ doorknob combination (M2C) made of plastic with a metal core and galvanized steel installation plate, a pair of plastic cover plates with a Euro profile cylinder hole, a 9x9mm square spindle, fastener screws and spacers.

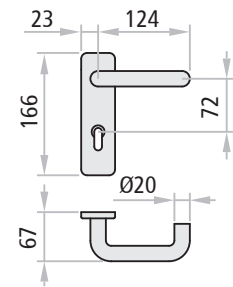

M1C handle colored RAL1023

| Colors available: |      |      |       |      |
|-------------------|------|------|-------|------|
| RAL               | RAL  | RAL  | RAL   | RAL  |
| 1023              | 7016 | 7035 | 9006* | 9010 |
|                   |      |      |       |      |

\*light aluminium

## STAINLESS STEEL HANDLES

On request, brushed stainless steel AISI 304 levers and cover plates can be provided which endow the product with a higher quality while at the same time ensuring optimal corrosion resistance and a noteworthy robustness of the entire set.

In addition, M1X, M2X, M11X and M20X handles are equipped with a return spring that maintains perfect alignment with the geometry of the door.

They are mounted on a galvanized steel mechanism and are supplied with fastener screws, spacers and a 9x9mm square spindle (where required).

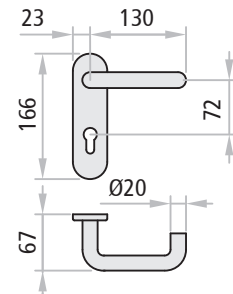

M1X stainless steel handle

### NOTE

Euro profile cylinder to be ordered separately (except for M11X and M20X handles).

Only M1C, M1X and M11X models are combinable with the three point locking mechanism.

On request, Proget door handles can be supplied in the stainless steel version "SERTOS", certified according to DIN EN 1906 with the maximum class of corrosion resistance (grade 5) and also tested for 1 million cycles for the durability class (five times the maximum grade 7)













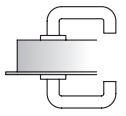



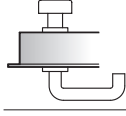



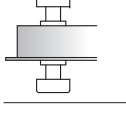



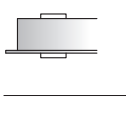



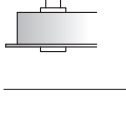

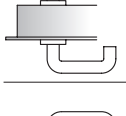

„SERTOS“ stainless steel version, available on request for Proget doors

# Handles

For locks with an inter-axis distance of 72 mm

## HANDLES

Rever, Univer and Proget doors may be equipped on request with handles with special functions other than those provided by standard handles.

| Versions   | description   |  | functioning  | use |
|--|---|--|--|-----|
|  <div style="display: flex; justify-content: space-around;"> <div style="text-align: center;"> <p>M1, M1R, M1C</p>   </div> <div style="text-align: center;"> <p>M1X, M1Xs</p>   </div> </div>    | <p>handle/handle combination with cylinder hole on both sides. For combination with lock with an inter-axis distance of 72 mm (015)</p>       | <p>door opening by handle or key from both sides</p>   | <p>applications in which both door opening directions are accessible without key</p>                     |     |
|  <div style="display: flex; justify-content: space-around;"> <div style="text-align: center;"> <p>M2, M2C</p>   </div> <div style="text-align: center;"> <p>M2X, M2Xs</p>   </div> </div>         | <p>handle/doorknob combination with cylinder hole on both sides. For combination with lock with an inter-axis distance of 72 mm (015)</p>     | <p>the doorknob side requires the key for opening</p>  | <p>applications in which only one of the door opening directions is accessible with a key</p>            |     |
|  <div style="display: flex; justify-content: space-around;"> <div style="text-align: center;"> <p>M4</p>   </div> <div style="text-align: center;"> <p>M4X, M4Xs</p>   </div> </div>              | <p>doorknob/doorknob combination with cylinder hole on both sides. For combination with lock with an inter-axis distance of 72 mm (015)</p>   | <p>both sides require the key for opening. The doorknobs serve for pushing or pulling the door</p> | <p>applications in which both door opening directions are accessible by key only</p>                     |     |
|  <div style="display: flex; justify-content: space-around;"> <div style="text-align: center;"> <p>M5</p>   </div> <div style="text-align: center;"> <p>M5X, M5Xs</p>   </div> </div>         | <p>plate/plate combination with cylinder hole on both sides. For combination with lock with an inter-axis distance of 72 mm (015)</p>         | <p>both sides require the key for opening</p>  | <p>applications in technical rooms with doors that usually remain closed and require key for opening</p> |     |
|  <div style="display: flex; justify-content: space-around;"> <div style="text-align: center;"> <p>M9</p>   </div> <div style="text-align: center;"> <p>M9X, M9Xs</p>   </div> </div>    | <p>doorknob/plate combination with cylinder hole on both sides. For combination with lock with an inter-axis distance of 72 mm (015)</p>      | <p>both sides require the key for opening. The doorknob serves for pulling the door</p>            | <p>applications in which both door opening directions are accessible by key only</p>                     |     |
|  <div style="display: flex; justify-content: space-around;"> <div style="text-align: center;"> <p>M11</p>   </div> <div style="text-align: center;"> <p>M11X, M11Xs</p>   </div> </div> | <p>handle/handle combination without cylinder hole. For combination with lock with an inter-axis distance of 72 mm (015)</p>                  | <p>opening is possible at any time using the handle</p>  | <p>applications in which the door never needs to be locked</p>   |     |
|  <div style="display: flex; justify-content: space-around;"> <div style="text-align: center;"> <p>M20</p>   </div> <div style="text-align: center;"> <p>M20Xs</p>   </div> </div>       | <p>handle/handle and thumbturn latch combination for interior closure. For combination with lock with star-shaped spindles only (Stel 15)</p> | <p>closure using thumbturn latch from inside. Emergency opening from outside with screwdriver</p>  | <p>typical closure for bathroom doors</p>  |     |

### NOTE

For stainless steel handle the Euro profile cylinder must be ordered separately (except for M11X, M11Xs and M20Xs handles).

Only M1, M1C, M1X, M1Xs, M11, M11X, M11Xs models are combinable with the three point locking mechanism.

**CYLINDERS**

On request Rever, Univer and Proget doors with standard locks (Std 015), MAC2 system control access locks or three-point locking mechanisms (3vie PRO) may be supplied with a Euro profile cylinder with three keys. They may also be provided in unique coding or group coded versions, or in combination with unique or group mastering.

**Cylinders for handles**

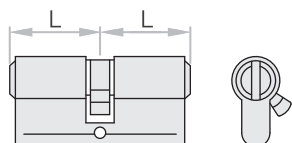

Nickel-plated cylinder equipped with 3 keys

**Versions available**

- standard cylinder
- single coded cylinder
- group coded cylinder
- sample key coded cylinder
- single mastered cylinder
- group mastered cylinder



**Lengths available**

|       |                |
|-------|----------------|
| 40/40 | Univer, Proget |
| 30/30 | Rever          |

**for doors**

**ATTENTION**

It is important to specify MAC lock combinations in the order.

**Cylinders with thumbturn latch**

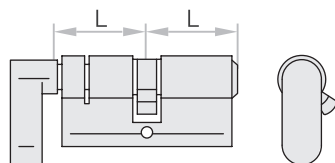

Nickel-plated cylinder with chrome-plated thumbturn latch equipped with 3 keys

**Versions available**

- standard cylinder with thumbturn latch
- group coded cylinder with thumbturn latch
- sample key coded cylinder with thumbturn latch
- single mastered cylinder with thumbturn latch
- group mastered cylinder with thumbturn latch
- mastered and emergency cylinder with thumbturn latch



**Lengths available**

|       |                |
|-------|----------------|
| 40/40 | Univer, Proget |
| 30/30 | Rever          |

**for doors**

**NOTE**

Cylinders to be combined with locks of NINZ doors must meet DIN 18254 standards. Main, master and/or emergency key (or keys) should be ordered separately - they are not included with the cylinder.

# Cylinders

For REVER - UNIVER - PROGET doors



## CYLINDERS FOR PANIC BARS AND MSC HANDLES

Standard panic bars are supplied with a Euro profile cylinder with three keys.

Cylinders with single coding, grouped coding or in combination with single or grouped mastering.

### Cylinders to be combined with MSC handle and panic bars (except EXUS DC)

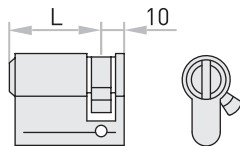

Nickel-plated cylinder equipped with 3 keys

#### Versions available

|                                |
|--------------------------------|
| standard half cylinder         |
| single coded half cylinder     |
| group coded half cylinder      |
| sample key coded half cylinder |
| single mastered half cylinder  |
| group mastered half cylinder   |



#### Lengths available

|       |                |
|-------|----------------|
| 40/10 | Univer, Proget |
| 30/10 | Rever          |

#### ATTENTION

It is important to specify MAC lock combinations in the order.

### Cylinders to be combined with EXUS DC panic bars

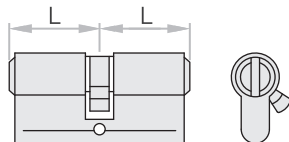

Nickel-plated cylinder equipped with 3 keys.

#### Versions available

|                           |
|---------------------------|
| standard cylinder         |
| single coded cylinder     |
| group coded cylinder      |
| sample key coded cylinder |
| single mastered cylinder  |
| group mastered cylinder   |



#### Lengths available

|       |                |
|-------|----------------|
| 45/40 | Univer, Proget |
| 35/35 | Rever          |

#### NOTE

Cylinders to be combined with the locks of NINZ doors must meet DIN 18254 standards.

Main, master and/or emergency key (or keys) should be ordered separately - they are not included with the cylinder.

## CONFIGURED AS NEEDED!

NINZ asks its partners to specify the system in the form of a key plan which, when prepared with care, serves as a map for optimizing the required intervention times (from order to installation) while ensuring that the mastering system meets the specific needs being requested.

Here are a few of the configurations that are available:

### 1) Standard

Cylinders with different keys.

### 2) Single coded

Cylinders with the same keys.

### 3) Grouped coded

Cylinders from the same group are coded alike.

### 4) Main/master key systems

Grouped master key system in which each cylinder can be opened with its own key or with a master key that can open cylinders from one group but not others; a general master key can open all cylinders from all different groups. Standard cylinders closed from the interior with a thumb-turn latch cannot be opened with the main/master key.

### 5) Frictioned emergency

"Frictioned cylinder" means that the main or master key can only open doors that have not been closed from inside, while the same doors can still be opened with the emergency key.

### 6) Encrypted with sample key

Sample key coding allows for cylinders to be coded on the basis of a sample key supplied by the customer.

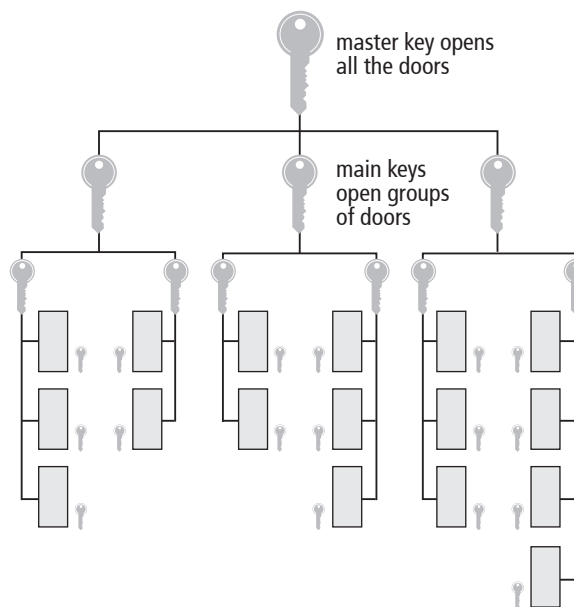

Key plan example for master key systems.

## KEYS

The order should specify the number of keys to be supplied with the mastered cylinders.

### Versions available

|               |   |
|---------------|---|
| main key      | opens all doors from the same group             |
| master key    | opens all the doors that have grouped mastering |
| emergency key | opens all doors                                 |



Key

# Door closers

For REVER - UNIVER - PROGET doors



ACCESSORIES  
doors

## DOOR CLOSER

The door closer regulates the closure of the door so that the door leaf returns properly to its final closed position after being released. Regulation is influenced by closure force, speed and the final impact.

Although Univer and Proget doors are equipped with spring hinges for automatic closure, the installation of door closers is recommended for wide and/or heavy doors and/or in the presence of windows on the leaf.

The door closer product is addressed by EU directive 89/106/CEE, which means it is subject to CE marking.

### CP1 with scissor arm

CE marked in conformity with EN 1154.

Rever, Univer and Proget doors are available, on request, with an overhead CP1 door closer with a silver-colored scissor arm.

The silver-colored CP1-G door closer is available for Proget doors, for installation on the push side of the door.

The CP1/CP1-G can be used for fire rated doors and is classified for 180° closure with a force varying from 3 to 4.

Proget doors ordered with CP1 are provided with pre-drilled installation holes on the door leaf and the frame. Standard Univer and Proget doors include internal reinforcements for the CP1 application.

#### NOTE

Scissor arm protrusion = 290 mm

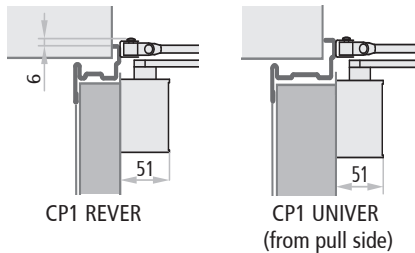

#### Optional colors:

RAL 9016 RAL 9005

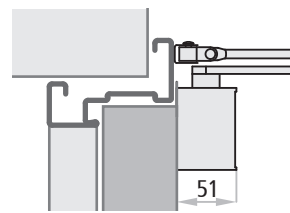

CP1 PROGET (from pull side)

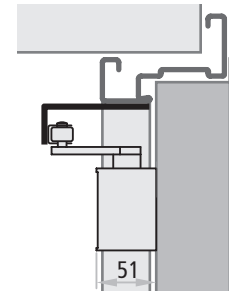

CP1-G PROGET (from push side)

### CP2 with slide channel

CE marked in conformity with EN 1154.

On request Rever, Univer and Proget doors are available with an overhead CP2 door closer with slide channel. Relative to the CP1, the advantage of this system is the absence of a protruding scissor arm.

The CP2 is suited for use on fire rated doors and has been classified for 180° closure with force level 4.

The silver-colored CP2-G door closer is available for Proget doors, for installation on the push side of the door, with force level 3.

Minimum wall opening width of 1200 mm for two leaved doors with two CP2/CP2-G applied.

Proget doors ordered with CP2 are provided with pre-drilled installation holes on the door leaf and the frame. Standard Univer and Proget doors include internal reinforcements for the CP2 application.

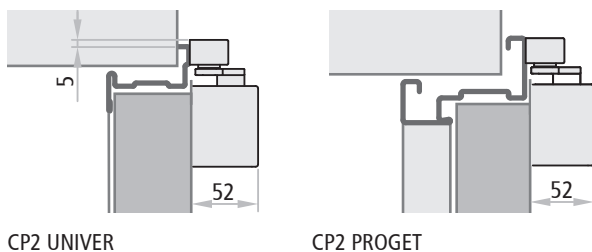

#### Optional colors:

RAL 9016 RAL 9005

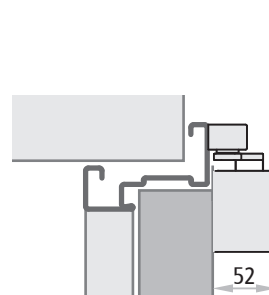

CP2 PROGET (from pull side)

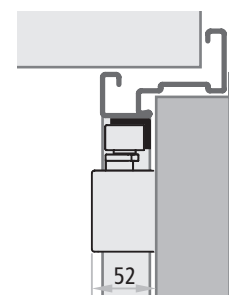

CP2-G PROGET (from push side)

## CP2-EMF with slide channel and electro-mechanical hold open device

CE marked in conformity with EN 1154 and EN 1155.  
 The CP2-EMF differs from the CP2 in that it has an electro-mechanical hold-open device that allows the door leaf to be locked at an angle ranging from 80° to 120°. During alarms or power outages, the hold-open device is unlocked and the door is closed by the door closer.  
 The CP2-EMF can be used on fire doors and has a maximum opening range of 120°, with a closing force set at 4. Minimum wall opening width of 1200 mm for two leaved doors with two CP2-EMF applied.  
 Proget doors ordered with CP2-EMF are provided with pre-drilled installation holes on the door leaf and the frame. Standard Univer and Proget doors include internal reinforcements for the CP2-EMF application.

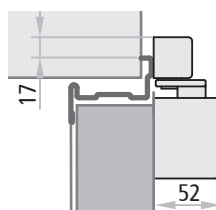

CP2 EMF UNIVER

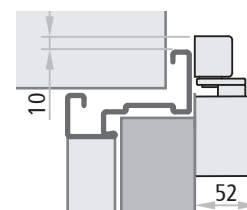

CP2 EMF PROGET

maximum opening in the absence of obstacles

| Model       | Single leaf / Active leaf | Inactive leaf | Closing force | Opening damping | Power supply | Absorption | CE Certification  | Standard                               |                    |
|-------------|---------------------------|---------------|---------------|-----------------|--------------|------------|-------------------|--|--------------------|
| CP1 - CP1-G | TS71                      | 180°          | 180°          | EN 3-4          |              |            | 0432-BPR-0054     | EN 1154                                |                    |
|             | TS72BCA                   | 180°          | 180°          | EN 2-4          | ✓            |            | 0432-BPR-0054     | EN 1154                                |                    |
| CP1-G       | TS71                      | 180°          | 180°          | EN 3            |              |            | 0432-BPR-0054     | EN 1154                                |                    |
|             | TS72BCA                   | 180°          | 180°          | EN 2-4          | ✓            |            | 0432-BPR-0054     | EN 1154                                |                    |
| CP2         | TS91                      | 175°          | 175°          | EN 4            |              |            | 0432-BPR-0051     | EN 1154                                |                    |
|             | TS93                      | 175°          | 175°          | EN 2-5          | ✓            |            | 0432-CPR-00026-30 | EN 1154                                |                    |
| CP2 -G      | TS91                      | 120°          | 120°          | EN 3            |              |            | 0432-BPR-0051     | EN 1154                                |                    |
|             | TS93                      | 120°          | 120°          | EN 2-5          | ✓            |            | 0432-CPR-00026-30 | EN 1154                                |                    |
| CP2 - EMF   | TS91                      | 120°          | 120°          | EN 4            |              | 24 Vcc     | 58,3 mA           | 0432-BPR-0051<br>0432-BPR-0025         | EN 1154<br>EN 1155 |
|             | TS93                      | 120°          | 120°          | EN 2-5          | ✓            | 24 Vcc     | 58,3 mA           | 0432-CPR-00026-30<br>0432-CPR-00026-60 | EN 1154<br>EN 1155 |
| CP2-EMF-V   | TS91                      | 120°          | 120°          | EN 4            |              | 48 Vcc     | 45,8 mA           | 0432-BPR-0051<br>0432-BPR-0025         | EN 1154<br>EN 1155 |
|             | TS93                      | 120°          | 120°          | EN 2-5          | ✓            | 48 Vcc     | 45,8 mA           | 0432-CPR-00026-30<br>0432-CPR-00026-60 | EN 1154<br>EN 1155 |

### NOTE

For the automatic closing of doors exposed to strong winds, the use of a door closer with a higher closing force is recommended.

# Closing regulators

For UNIVER - PROGET fire doors



## CLOSING REGULATOR

Closing regulators administer the closure of two-leaved doors so that the inactive leaf is overlaid on the active leaf upon final closure. This is why it is mandatory to apply closing regulators to all two-leaved fire doors.

### RC/STD

CE marked in conformity with EN 1158.

The RC/STD closing regulator device is distinct from the door closer and is a standard element of all Univer and Proget two-leaved fire doors.

In Proget doors the closing regulator is inserted into the upper horizontal groove of the frame, while in Univer doors it is supplied separately with an anchoring rod to be installed on site. In comparison with other regulators which are separate from the door closer, the advantage of the RC/STD regulator is that it is not visible when the door is closed.

The RC/STD regulator is suited for use on fire doors and is classified for forces ranging from 3 to 5.



### ATTENTION

In case of two-leaved Proget fire-rated doors with environmental characteristics it is mandatory to apply the RC2 closing regulator (to be ordered separately) instead of the RC/STD.

### RC2 system

CE marked in conformity with EN 1154 and EN 1158.

The self-closing RC2 system for the self closing of two-leaved doors incorporate two CP2 with force EN 4 with a slide channel and a regulator integrated in the upper sliding guide. The entire system is silver colored.

The silver-colored RC2-G system is available for Proget doors, for installation on the push side of the door, with force EN 3.

Proget fire doors with environmental characteristics must be ordered endowed with the RC2 system.

On request, two-leaved Univer and Proget doors are available with an RC2 regulator instead of the RC/STD.

The RC2/RC2-G system presents clear advantages:

- no protruding door-closer arms
- regulator concealed in the upper guide (even when the door is open)
- controlled closure of both leaves

The RC2 regulator is suited for use on fire doors and is classified for both door closers with force EN 4; the RC2-G regulator is suited for use on Proget fire doors (installation from push side) and is classified for both door closers with force EN 3.

Minimum wall opening width: 1200 mm for the RC2; 1500 mm for the RC2-G. Minimum inactive leaf width: 370 mm for the RC2; 600 mm for the RC2-G.

Proget doors ordered with RC2 are provided with pre-drilled holes for the installation of two CP2 door closers on the leaves and the slide channel on the frame. The installation holes in Univer doors need to be drilled on site for anchoring to the internal reinforcement of the leaves.

There are two systems for applying it to the door:

- separated from the self-closing system of the spring hinge or the door closer
  - incorporated into the closure system of the door closer
- Closing regulators are addressed by EU directive 89/106/CEE, which means they are subject to CE marking.

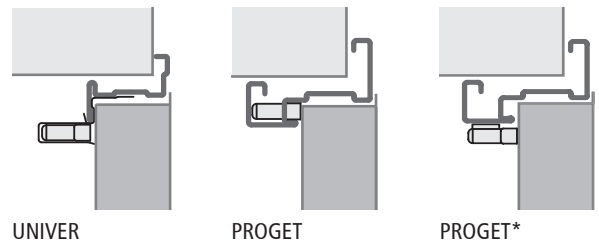

\* Position of RC/STD closing regulator in case of two-leaved Proget door with additional performances

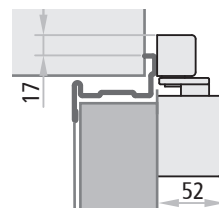

RC2 UNIVER

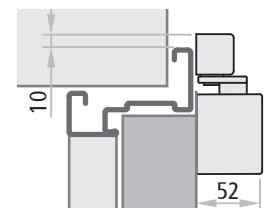

RC2 PROGET (from pull side)

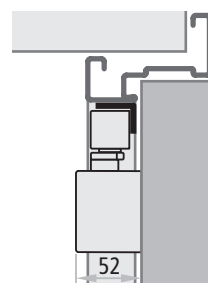

RC2-G PROGET (from push side)

Optional colors  
(except for RC2-G):

RAL 9016 RAL 9005



# Closing regulators

For UNIVER - PROGET fire doors



## RC2-EMF1 system

CE marked in conformity with EN 1154, EN 1158 and EN 1155. The RC2-EMF1 system differs from the RC2 in that it has an electro-mechanical hold-open device that allows the door leaf to be locked at an angle ranging from approx. 80° to 130°. The active leaf is held open by the closing regulator system. During alarms or power outages, the hold-open system is unlocked and the door is closed by the door closer. The entire system is provided in the standard silver color.

### The RC2-EMF1 system presents multiple advantages:

- possibility of holding the leaves open in the desired position
- no visible magnets
- no protruding door closer arms
- regulator concealed in the upper guide (even when the door is open)
- controlled closure of both leaves

The RC2-EMF1 system is suited for use on fire rated doors and is classified for both door closers with force level EN 4.

Minimum wall opening width of 1200 mm and minimum of 370 mm for the inactive leaf.

Proget doors ordered with RC2-EMF1 are provided with pre-drilled installation holes on the door leaf and the frame. The Univer door series includes internal reinforcements for application of the two door closers.

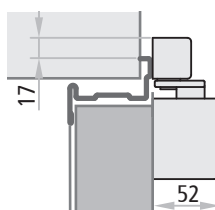

RC2-EMF1 UNIVER

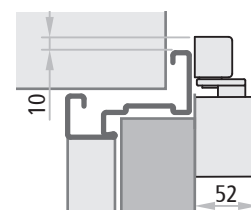

RC2-EMF1 PROGET

maximum opening in the absence of obstacles

| Model      | active leaf | inactive leaf | Closing force |       | Opening damping | Power supply | absorption | CE Certification  | Standard                      |
|------------|-------------|---------------|---------------|-------|-----------------|--------------|------------|---|-------------------------------|
|            |             |               | EN            | Class |                 |              |            |   |                               |
| RC/STD     | 180°        | 180°          | EN 3-5        |       |                 | -            | -          | 0425-ICIM-1153  | EN 1158                       |
| RC2        | TS91        | 175°          | EN 4          |       | ✓               | -            | -          | 0432-BPR-0051<br>0432-BPR-0026                              | EN 1154<br>EN 1158            |
|            | TS93        | 175°          | EN 2-5        |       | ✓               | -            | -          | 0432-CPR-0026-30<br>0432-CPR-0026-83                        | EN 1154<br>EN 1158            |
| RC2-G      | TS91        | 120°          | EN 3          |       |                 | -            | -          | 0432-BPR-0051<br>0432-BPR-0026                              | EN 1154<br>EN 1158            |
|            | TS93        | 120°          | EN 2-5        |       | ✓               | -            | -          | 0432-CPR-0026-30<br>0432-CPR-0026-83                        | EN 1154<br>EN 1158            |
| RC2-EMF1   | TS91        | 175°          | EN 4          |       |                 | 24 Vcc       | 58,3 mA    | 0432-BPR-0051<br>0432-BPR-0026<br>0432-BPR-0025             | EN 1154<br>EN 1158<br>EN 1155 |
|            | TS93        | 175°          | EN 2-5        |       | ✓               | 24 Vcc       | 58,3 mA    | 0432-CPR-00026-30<br>0432-CPR-00026-83<br>0432-CPR-00026-60 | EN 1154<br>EN 1158<br>EN 1155 |
| RC2-EMF1-V | TS91        | 175°          | EN 4          |       |                 | 48 Vcc       | 45,8 mA    | 0432-BPR-0051<br>0432-BPR-0026<br>0432-BPR-0025             | EN 1154<br>EN 1158<br>EN 1155 |
|            | TS93        | 175°          | EN 2-5        |       | ✓               | 48 Vcc       | 45,8 mA    | 0432-CPR-00026-30<br>0432-CPR-00026-83<br>0432-CPR-00026-60 | EN 1154<br>EN 1158<br>EN 1155 |

## NOTE

For the automatic closing of doors exposed to strong winds, the use of a door closer with a higher closing force is recommended.

# Automatic door sweep

For NINZ doors



## AUTOMATIC DOOR SWEEP

On request, Rever, Univer and Proget doors are available with an automatic door sweep to prevent air drafts from entering through the crack between the leaf and the floor. It complements the sealing applied to the frame to provide better acoustic insulation and better air sealing for the door.

It is applied on the push side by using screws to attach it directly to the sheet metal of the door, after which the mechanism is completely covered with an anodized aluminium profile. On request, it can also be provided in the same color as the door leaf.

It is applied on site following door installation so that it can be adjusted to the actual leaf height.



## FIELDS OF APPLICATION FOR THE AUTOMATIC DOOR SWEEP

### REVER doors



1 leaf/active  
UNIVER  
REVER

| FM L one-leaved door | L1 active leaf      | L2 inactive leaf with 30x4mm profile | seals to be used |
|----------------------|---------------------|--------------------------------------|------------------|
| from 500 to 569 mm   | from 500 to 569 mm  | from 400 to 491 mm                   | L 480 mm         |
| from 570 to 719 mm   | from 570 to 719 mm  | from 492 to 641 mm                   | L 630 mm         |
| from 720 to 869 mm   | from 720 to 869 mm  | from 642 to 791 mm                   | L 780 mm         |
| from 870 to 1019 mm  | from 870 to 1000 mm | from 792 to 941 mm                   | L 930 mm         |
| from 1020 to 1169 mm |                     | from 942 to 1000 mm                  | L 1080 mm        |
| from 1170 to 1319 mm |                     |                                      | L 1230 mm        |
| from 1320 to 1350 mm |                     |                                      | L 1330 mm        |

### UNIVER fire and multipurpose doors

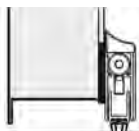

inactive leaf  
UNIVER  
REVER

| FM L one-leaved door | L1 active leaf      | L2 inactive leaf with 30x4mm profile | seals to be used |
|----------------------|---------------------|--------------------------------------|------------------|
| from 500 to 569 mm   | from 500 to 570 mm  | from 400 to 496 mm                   | L 480 mm         |
| from 570 to 719 mm   | from 571 to 720 mm  | from 497 to 646 mm                   | L 630 mm         |
| from 720 to 869 mm   | from 721 to 870 mm  | from 647 to 796 mm                   | L 780 mm         |
| from 870 to 1019 mm  | from 871 to 1000 mm | from 797 to 946 mm                   | L 930 mm         |
| from 1020 to 1169 mm |                     | from 947 to 1000 mm                  | L 1080 mm        |
| from 1170 to 1319 mm |                     |                                      | L 1230 mm        |
| from 1320 to 1350 mm |                     |                                      | L 1330 mm        |

### PROGET fire and multipurpose doors

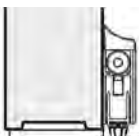

1 leaf active  
or inactive  
PROGET

| FM L one-leaved door | L1 active leaf       | L2 inactive leaf     | seals to be used |
|----------------------|----------------------|----------------------|------------------|
| from 500 to 574 mm   | from 500 to 576 mm   | from 350 to 495 mm   | L 480 mm         |
| from 575 to 724 mm   | from 577 to 726 mm   | from 496 to 645 mm   | L 630 mm         |
| from 725 to 874 mm   | from 727 to 876 mm   | from 646 to 795 mm   | L 780 mm         |
| from 875 to 1024 mm  | from 877 to 1026 mm  | from 796 to 945 mm   | L 930 mm         |
| from 1025 to 1174 mm | from 1027 to 1076 mm | from 946 to 1095 mm  | L 1080 mm        |
| from 1175 to 1324 mm | from 1177 to 1326 mm | from 1096 to 1245 mm | L 1230 mm        |
| from 1325 to 1340 mm | from 1327 to 1330 mm | from 1246 to 1330 mm | L 1330 mm        |

# Roofing - Drip-steel profile - Protective plates

For NINZ doors



ACCESSORIES  
doors

## ROOFING

Upon request for Univer and Proget doors, to be ordered together with the door.

Conceived for exterior use of metallic doors, the roofing protects against infiltration of rain from above between the door edge and the rebate of the frame. The small protusion and RAL painting for exterior use in the same color of the frame complete the design of the door.

To be applied onto the wall, in contact with transom.

Made out of galvanized sheet metal with thickness 10/10 mm, painted with RAL for exterior use (in the frame color), complete with holes for fixing to the wall (screws and plugs excluded). Available for doors with FM L from 500 to 2660 mm (supplied in two elements for FM L > 2360 mm).

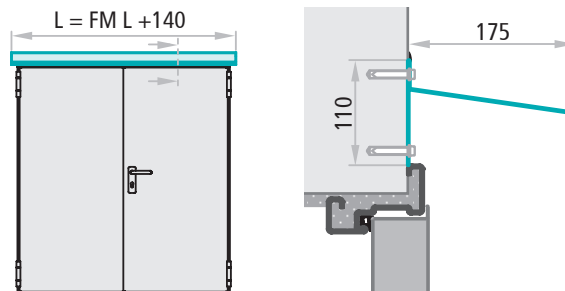

### ATTENTION

The roofing performs the function of a barrier against vertical rain limited to the upper part of the door. Therefore the roofing does not protect any eventual window or ventilation louvers on the door, so for these cases provide canopies or awnings for a complete protection of the product.

## DRIP-STEEL PROFILE

On request for Univer and Proget one-leaved doors. Normally used to prevent condensation from dripping down the door leaf and puddling beneath the door. The profile is made of "Sendzimir" processed galvanized sheet metal painted the color of the door leaf.

It is applied usually on the push side of the leaf on site after being cut to measure, to be attached with the screws provided.

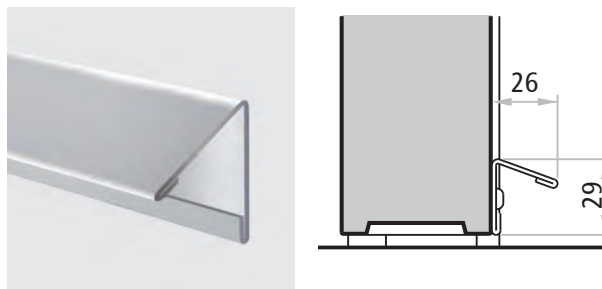

| Lengths available | FM L door leaf |
|-------------------|----------------|
| 828 mm            | to 800 mm      |
| 928 mm            | to 900 mm      |
| 1028 mm           | to 1000 mm     |
| 1378 mm           | to 1350 mm     |

## PROTECTIVE PLATES AND KICKPLATES

On request for 1 and 2 leaf Univer and Proget doors, specifying the side of application (pull or push).

Their main function is to protect the parts of the door that are vulnerable to being scraped by carts, hospital beds, etc.

They are made of AISI 304 brushed stainless steel sheet metal with a standard height of 230 mm.

For on-site attachment with two-sided adhesive factory applied on the back, at the bottom of the door (kick plate) or at handle height (protective plate).



Holes are factory prepared for the passage of the handle panel and cylinder



Example of application on the push side

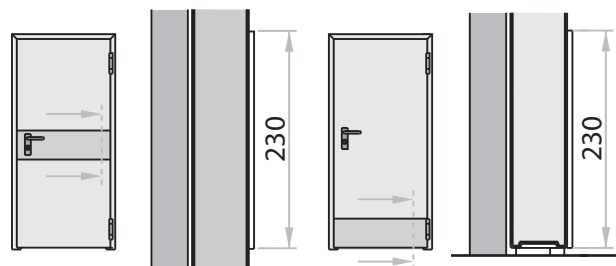

Protection plates

Kick plates

| Heights available | FM L door leaf |
|-------------------|----------------|
| 230 mm            |                |
| 300 mm            |                |
| 400 mm            |                |
| 500 mm            |                |
| 600 mm            | to 1350        |
| 700 mm            |                |
| 800 mm            |                |
| 900 mm            |                |

# Wall screws - Subframe

For NINZ doors



## WALL SCREWS FOR FASTENING WITHOUT PLUGS

Field of use: installation of Proget insulated or multipurpose doorframes to the wall or subframe using screws but no plugs. Designed for installation into concrete, full bricks, half-full bricks, lightened cement and other materials.

**Advantages:** saves time and money thanks to direct attachment of the frame to the wall, with no need to enlarge the holes for plugs. Thanks to the black galvanization, the screws blend in smoothly with the FC sealing.

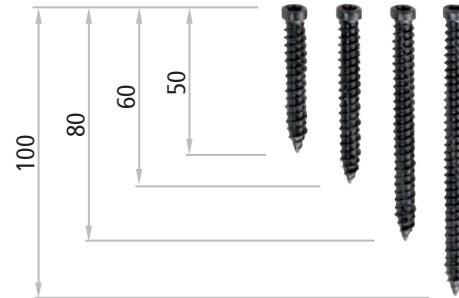

| Dimensions     | description   |
|----------------|---|
| Ø 7,5 x 50 mm  | for attachment to metal subframes                     |
| Ø 7,5 x 60 mm  | for attachment to concrete and especially thick walls |
| Ø 7,5 x 80 mm  | for attachment to walls of average thickness          |
| Ø 7,5 x 100 mm | for attachment to walls of lower thickness            |

### NOTE

Holes should be drilled using a Ø6mm stone drill bit.

## SUBFRAME

Subframe made of 30x15x1,5mm hollow section profiles, derived from hot-galvanized steel coil, endowed with anchors for mortar fixing and removable spacers for the final installation.

To be ordered separately (mandatory for REI 60 and REI 120 Proget doors with installation onto subframe with screws).

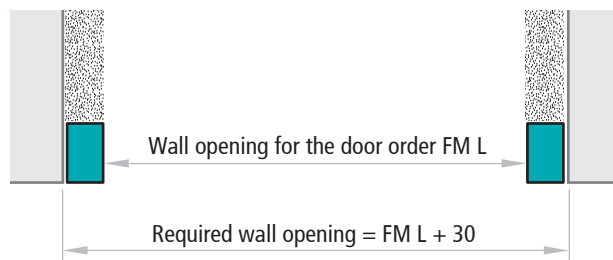

Horizontal cross section

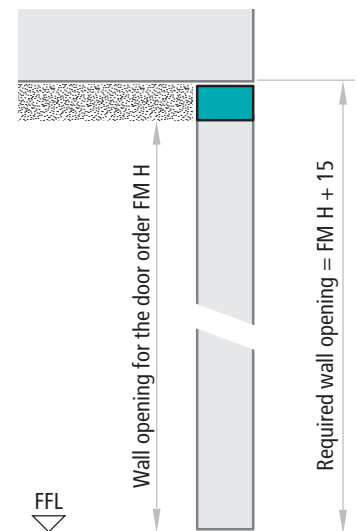

Vertical cross section

# MAC® Multifunctional Access Control

## Controlled opening system

**NINZ**  
FIRE DOORS

Installation on the door of MAC and MAC FAILSAFE systems allow to control access by electric impulse.

The particularity of the MAC and MAC FAILSAFE system is to integrate all command and control functions in the lock, which simplifies the electrical works required on site. Solenoid and electric card are inside the lock, and therefore better protected. The locks are marked CE in accordance with the EMC Directive (electromagnetic compatibility)

### Differences between MAC and MAC FAILSAFE systems:

- the MAC systems, in the event of a power failure, allow the opening only via key or panic/emergency exit device. Thus MAC systems are recommended in situations where the door shall remain closed, even in case of power failure
- the MAC FAILSAFE systems guarantee access in the situation of power failure. Thus MAC FAILSAFE systems are recommended in situations where free passage must be assured, even in case of power failure

### The MAC system offers multiple advantages, such as:

- possibility of 12 or 24V AC/DC power supplies, which avoids problems due to inadequate voltage
- low power consumption, max 350 mA regardless of the operating voltage (basically from 300ma with 10V up to 350ma with 30V)
- DC power demand (10vdc - 24vdc) = 10 watts
- AC power demand (12V/24V +/- 10%) = 24VA
- timer incorporated, time set at 30 sec., eliminating the need for external timers. Further, in case of delivery with the door, an automatic reset function (reset of the timer) for every door opening is provided
- if powered by electrical contacts, the system will automatically reset at each door opening (zero time)
- If powered by a cable entry, the system will reset at the expiry of 30 sec.
- Red/green LED on handle plate which indicates the status of the system is active or deactivated, thus avoiding unnecessary mechanical stress.
- possible continuous activation of the handle via switch (not included)
- ready for the connection of a optional remote sensor (not supplied) for remote signaling of lock activation/deactivation
- guaranteed access in case of power failure (only for FAILSAFE version)

The MAC and MAC FAILSAFE systems can be delivered installed onto the door with internal wiring through the leaf and electrical contacts between the leaf and the doorframe. The KIT version includes a flexible cable sleeve and the electrical cables are to be installed externally. The MAC system is not compatible with the three point lock.

### NOTE

Before the installation of doors with MAC locks it is necessary to prepare the power supply (active door leaf side in case of double leaved doors) at a height of approx. 800mm from the finished floor level and in proximity of the wall angle, where the door frame will be mounted. The power wires must have a section of 0,75-1,0mm<sup>2</sup> and must be flexible.



Plastic handle with LED



Stainless steel handle with LED



Electrical contacts between leaf and doorframe

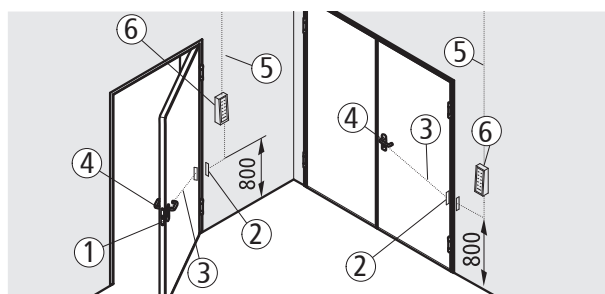

Diagram of components

*Supplied with the door: lock with solenoid and electronic chip with timer incorporated (1), electrical contacts between leaf and frame (2), internal wiring inside the leaf (3); supplied to be installed: handle and cover plate with red/green LED and connectors (4).*

*Not included: power supply for doorframe contacts (5), opening button and command accessories (6).*

*Unlike the delivery together with the door, the KIT (supplied separately from the door) offers a flexible cable sleeve between the door leaf and the power supply instead of the double electrical contacts. In case of a handle the installation of a cable duct onto the door leaf (not supplied) is necessary for the power supply.*

## MAC1 AND MAC1 FAILSAFE SYSTEM

### Door opening in case of power failure (LED off)

- MAC1: from pull side only by key; from push side by panic bar or emergency handle
- MAC1 FAILSAFE: from pull side by handle (or key); from push side by panic bar or emergency handle

### Operating mode

The system controls access from the pull side of the door. With the lock locked by key, the access consent is possible via electric impulse (button, badge reader, etc.), which gives power supply in case of MAC1 or it turn off in case of MAC1 FAILSAFE, while opening is always possible from the push side by means of the panic bar or emergency handle. Activation of the handle is signaled by illumination of the "green LED," while the "red LED" indicates when the handle is idle. Both LEDs are off when no power is being supplied.

### Timed function

In this mode, the activation time lasts 30 seconds before the handle is returned to idle. In case of delivery with the door, if the door is opened within the 30 seconds, the timer is automatically reset to zero.

### Continuous "day time" function

In this mode the handle is continuously enabled by an electric switch (not supplied) for a longer period (for example during the day), which keeps the lock always enabled. The green LED remains switched on (not valid for the "Kit" version) and is switched off only for the period between the door's opening and its fully closure.

MAC1 can be combined with any BM type panic bar and M3 emergency handles (to be ordered on the side).

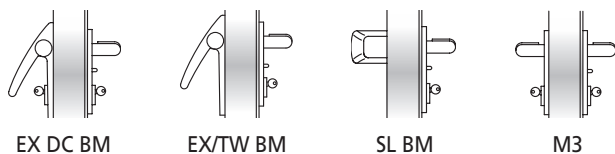

## MAC2 AND MAC2 FAILSAFE SYSTEM

### Door opening in case of power failure (LED off)

- MAC2: from both sides by key only
- MAC2 FAILSAFE: from both sides by handle (or key)

### Operating mode

The system controls access from both sides of the door. With the lock locked by key, the access consent is possible via electric impulse (button, badge reader, etc.), which gives power supply in case of MAC2 or it turn off in case of MAC2 FAILSAFE. Activation of both handles is signaled by illumination of the "green LED," with the "red LED" signaling when the handles are idle. Both LEDs are off when no power is being supplied.

### Timed function

In this mode, the activation time lasts 30 seconds before both handles are returned to idle. In case of delivery with the door, if the door is opened within the 30 seconds, the timer is automatically reset to zero.

### Continuous "day time" function

In this mode both handles are continuously enabled by an electric switch (not supplied) for a longer period (for example during the day), which keeps the lock always enabled. The green LEDs remain switched on (not valid for the "Kit" version) and are switched off only for the period between the door's opening and its fully closure.

MAC2 standard delivery with M1 plastic handle. Upon request an M1X stainless steel handle can be delivered (to be ordered on the side).

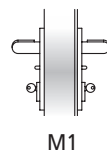

## MAC3 AND MAC3 FAILSAFE SYSTEM

### Door opening in case of power failure (LED off)

- MAC3: from push side only by key; from pull side by the M3tir/M3Xtir emergency handle
- MAC3 FAILSAFE: from push side by handle (or key); from pull side by the M3tir/M3Xtir emergency handle

### Operating mode

The system controls access from the push side of the door. With the lock locked by key, the access consent is possible via electric impulse (button, badge reader, etc.), which gives power supply in case of MAC3 or it turn off in case of MAC3 FAILSAFE, while opening is always possible from the pull side by means of the emergency handle. Activation of the handle is signaled by illumination of the "green LED," while the "red LED" indicates when the handle is idle. Both LEDs are off when no power is being supplied.

### Timed function

In this mode, the activation time lasts 30 seconds before the handle is returned to idle. In case of delivery with the door, if the door is opened within the 30 seconds, the timer is automatically reset to zero.

### Continuous "day time" function

In this mode the handle is continuously enabled by an electric switch (not supplied) for a longer period (for example during the day), which keeps the lock always enabled. The green LED remains switched on (not valid for the "Kit" version) and is switched off only for the period between the door's opening and its fully closure.

MAC3 standard delivery with M3tir plastic handle. Upon request an M3Xtir stainless steel handle can be delivered (to be ordered on the side).

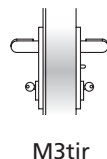

### NOTE

Before the installation of doors with MAC locks it is necessary to prepare the power supply (active door leaf side in case of double leaved doors) at a height of approx. 800mm from the finished floor level and in proximity of the wall angle, where the door frame will be mounted. The power wires must have a section of 0,75-1,0mm<sup>2</sup> and must be flexible.

# Electric handles

## Controlled opening system

### ELM/MT AND ELM/FS MULTI-VOLTAGE ELECTRIC HANDLES

Controlled door opening system that employs an electronic device to activate the handle. The latter is equipped with an internal timer with a 30 seconds time allowance for opening the door, after which the electric handle is deactivated. The handle can be activated for longer time periods by means of the electrical switch.

The illumination of a green LED and sounding of an acoustic signal (buzzer) indicate handle activation, while a red LED indicates deactivation.

In the absence of power the electric handle ELM/mt is free (in neutral) and therefore it is not possible to open the door. In the absence of power the electric handle ELM/fs Failsafe is always enabled and therefore the door can be opened.

**When ordered together with the door, the ELM/mt and ELM/fs systems include:**

electric handle, electrical contacts between the leaf and the frame, power cable inside the door connected to electrical contacts, command panel, lock and fixing screws.

**If ordered separately from the door, the system includes:**

electric handle, command panel and fixing screws.

### ELM/CISA MULTI-VOLTAGE ELECTRIC HANDLE

Controlled door opening system that employs an electronic device to activate the handle. Equipped with a separate timer (for insertion into the switch box) which can be set for different opening times: from a minimum of 0,1 second to a maximum of 10 days.

Equipped with green LED that signal activation of the handle.

The ELM/cisa system includes: electric handles, 2 meters of power cable, cable sleeve for the connection between the leaf and the frame, 8/9 square spindle, fixing screws, adjustable timer packaged separately.

### PANIC BARS FOR COMBINATION WITH ELM/MT, ELM/FS OR ELM/CISA ELECTRIC HANDLES

The controlled opening direction is from the pull side of the door (electric handle side). Locking the lock by key blocks the electric handle functioning, while opening is still possible via the panic bar on the push side.

Use: one- or two-leaved doors for anti-panic exits when access control is desired on the pull side.

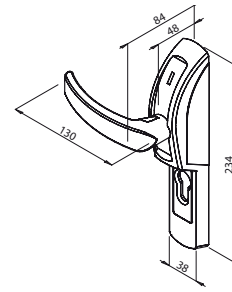

#### Technical data

|                               |                                   |
|-------------------------------|-----------------------------------|
| power supply                  | 12-24V AC/DC                      |
| current absorbed              | at 12 V: 500 mA - at 24 V: 200 mA |
| startup current               | at 12 V: 700 mA - at 24 V: 300 mA |
| minimum operating temperature | -5°C                              |

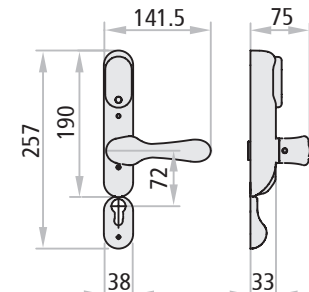

#### Technical data

|                         |                                    |
|-------------------------|------------------------------------|
| power supply            | 12-24V AC/DC                       |
| current                 | absorbed: 360 mA - startup: 800 mA |
| operational temperature | -20°C ÷ +80°C                      |

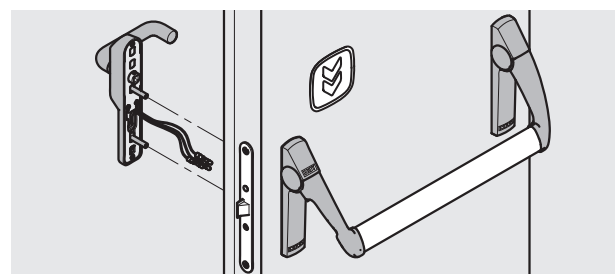

Exus

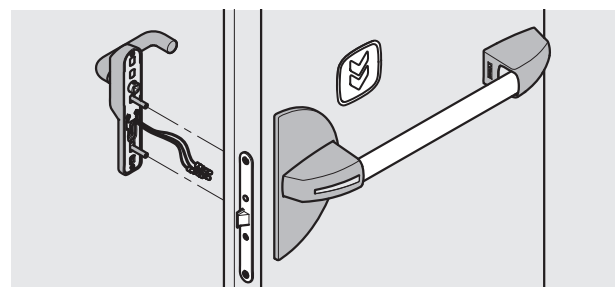

Slash

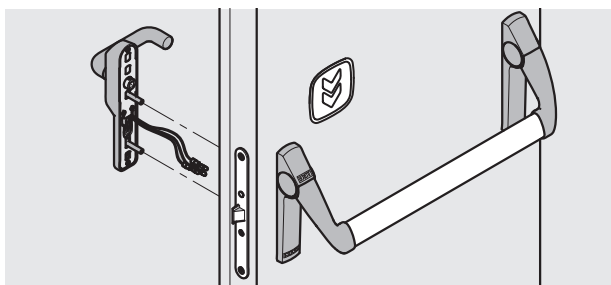

Twist

# Electric handles - Electromagnetic sensor

Controlled opening system

**NINZ**  
FIRE DOORS

## HANDLES FOR COMBINATION WITH ELM/MT, ELM/FS OR ELM/CISA ELECTRIC HANDLES

### MSC, MSC-X

Use: one- or two-leaved doors when control is desired for one of the two opening directions. Locking with the key blocks opening in both directions. Controlled opening may be for either the push or pull direction, depending on where the electric handle is applied.

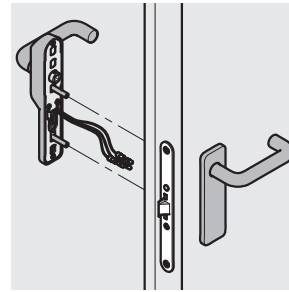

MSC

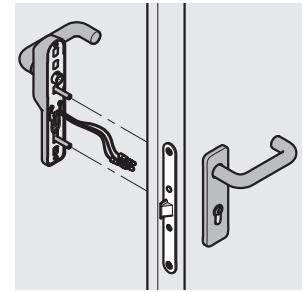

MCC/S

### MCC/S, MCC/S-X

Use: for one- or two-leaved doors where access is to be controlled from the pull side only (electric handle side). Locking with the key blocks opening from the push side, but not from the side where the electric handle is applied.

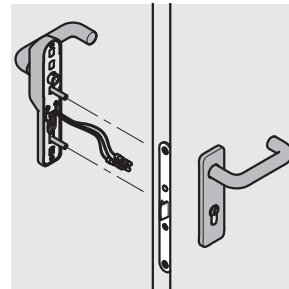

MCC/T

### MCC/T, MCC/T-X

Use: for one- or two-leaved doors where access is to be controlled from the push side only (electric handle side). Locking with the key blocks opening from the pull side, but not from the side where the electric handle is applied.

## EMERGENCY HANDLES FOR COMBINATION WITH ELM/MT OR ELM/FS ELECTRIC HANDLES

### M3, M3X

Use: one- or two-leaved doors for emergency exits when access control is desired on the pull side. The controlled opening direction is from the pull side of the door (electric handle side). Locking the lock by key blocks the operation of the electric handle, while opening remains possible via the M3 or M3X emergency handle.

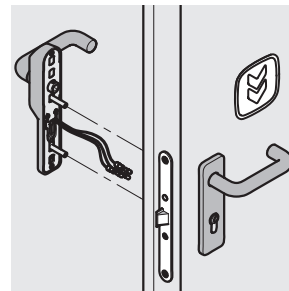

M3

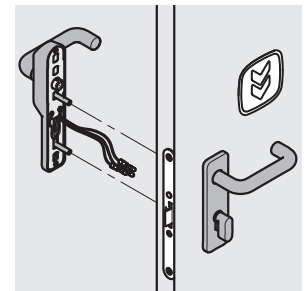

HOT-CIL

### HOT-CIL, HOT-CIL-X

Use: for hotel rooms doors. The controlled opening direction is from the push side of the door (electric handle side). Opening from push side is possible with an electric consent at the electric handle. Opening is always possible from the room side of the door via the HOT-CIL or HOT-CIL-X emergency handle, also in case of lock locked by thumbturn latch.

## ELECTROMAGNETIC SENSOR

The electromagnetic sensor allows to verify the position of the door leaf. To be applied to the door, composed of two elements: one electromagnetic sensor with two cables and one magnet.

### Technical data

|                         |                                       |
|-------------------------|---------------------------------------|
| maximum voltage         | 200 V DC / 500 mA with resistive load |
| internal switch contact | n.o. (n.c. with magnet aligned)       |
| operational temperature | +5 / +40 °C                           |

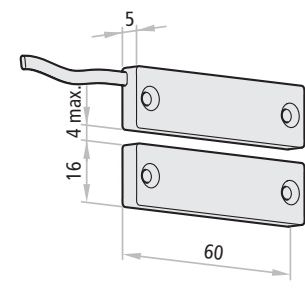

# Door blocking electromagnet

Controlled opening system



## DOOR BLOCKING ELECTROMAGNET

This system is for use in special situations when the doors remain closed and should only be opened with electrical consent. The electrically powered electromagnet holds the door closed with a holding force of approximately 300kg, rendering the action of the handle ineffective. Only electrical commands (badge reader, key button, etc.) or electrical consent from the fire detector system can deactivate the electromagnet making a door opening possible.

### Operating mode

The door is held closed by the electromagnet (01) and the bolt of the lock. Opening from the outside can happen via magnetic card (04) using the Badge reader (02) of the card control system or any other system of choice and by retracting the bolt using the handle or key.

From the inside, the deactivation of the electromagnet is caused by the unlock button (03) (also remotely) or with the same system used for the pull side, while the locking bolt must still be retracted using the handle or key. The activated electromagnet signals its state with a red LED, whereas the green LED signals the temporary deactivation. Further a relay AC/DC signaling the electromagnetic state is supplied.

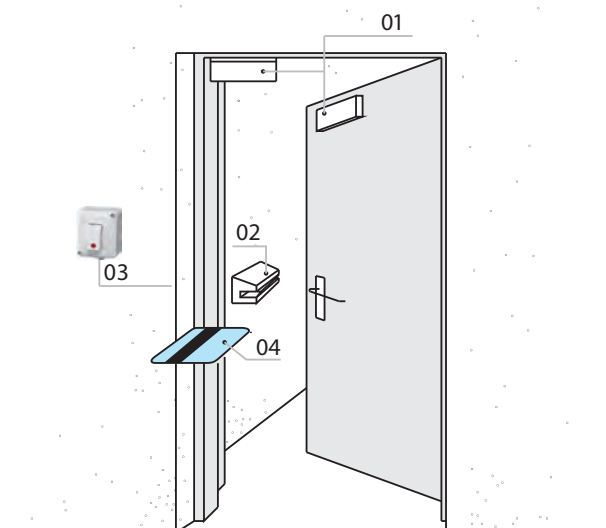

**NOTE**  
Unlocking of the door is only possible if the door is not locked by key.

### Technical data

|                  |                                   |  |                     |
|------------------|-----------------------------------|--|---------------------|
| power supply     | 12/24V DC                         | time delay                             | 0 ÷ 90 sec.         |
| current absorbed | 500mA at 12V DC - 250mA at 24V DC | electromagnetic compatibility standard | EMC - UNI CEI 70011 |
| force            | up to 300kg.                      | certificate Nr.                        | 0123/02             |

## COMPONENTS INCLUDED WITH THE DOOR BLOCKING ELECTROMAGNET

### For Proget doors

Door blocking electromagnet, withstanding force 300kg, 12/24V DC, fastener plate, anchor with stainless steel fastener backplate.

### For Rever/Univer doors

Door blocking electromagnet, withstanding force 300kg, 12/24V DC, fastener plate and angle bar, anchor with stainless steel fastener backplate.

### Control system:

- "Access" code keypad
- Card-based control system
- Biometric fingerprint reader
- Unlock button

### NOTE

Detailed specifications for the Control system are found on the "Command accessories" page.



PROGET electromagnet



REVER/UNIVER electromagnet

# Power supply/command accessories

For MAC®- ELM/mt- ELM/fs - ELM/cisa- Door blocking electromagnet-controlled opening systems

**NINZ**  
FIRE DOORS

## CONTROL SYSTEMS AND RELATED ACCESSORIES

### “Access” code keypad

Keypad with 10 numeric buttons plus an Enter key, including control unit for 1 door, timer incorporated (0,5÷25 sec.) and flat cable. Up to 500 recordable different codes, composed from 1 to 10 digits.

#### Technical data

|              |                 |
|--------------|-----------------|
| power supply | 12 ÷ 18 V AC/DC |
| output       | relay           |

### Card-based control system

Card control system, including control unit for 1 door, timer and AC adapter incorporated, badge reader, flat cable, three blank badges and a coded badge. Management of access control for multiple doors by P.C.

#### Technical data

|              |                     |
|--------------|---------------------|
| power supply | 230 V AC            |
| output       | 12 V DC, max. 0,5 A |

### Biometric fingerprint reader

Biometric reader for reading of fingerprints and transformation into key codes. Includes an internal unit for registering, memorizing and cancelling users, external unit for the reading of fingerprints and an autonomous low voltage AC adapter. The power supply for the management of the door is not included.

#### Technical data

|              |          |
|--------------|----------|
| power supply | 230 V AC |
| output       | relay    |

### Unlock button

Unlock button with white casing and control light.

### Power supply Switching

Can be combined with “Access code keypad”, with “Biometric fingerprint reader” and for the management of:

- max. Nr. 10 MAC® Multifunction Access Control \*
- or max. Nr. 5 electromagnets door blocking
- or max. Nr. 5 ELM/mt or ELM/fs electric handles \*
- or max. Nr. 5 ELM/cisa electric handles \*

\* provided that they are not commanded simultaneously

#### Technical data

|              |               |
|--------------|---------------|
| power supply | 230 V AC      |
| output       | 12 V DC - 3 A |

#### NOTE

It is possible to wire a couple of buffer batteries to the power supply switching (see “Door-holding systems”).



„Access” code keypad

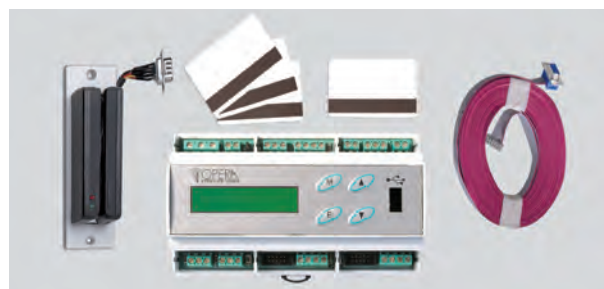

Card-based control system



Biometric fingerprint reader



Unlock button



Power supply switching

# Door-holding systems

For fire doors and gates

**NINZ**  
FIREDOORS

## C2 MONO-ZONE CENTRAL UNIT

Certified in accordance with EN 54-2 and EN 54-4 standards. The central unit designed and built in conformity with UNI EN 54 standards, which regulate unit for fire alarms and related accessories which each must conform with EN 54 standards.

To use for the management of the door-holding electromagnets for fire-rated closures. Control all outputs towards the heat and smoke detectors, the alarm activation/reset buttons, the external siren and the charge of buffer batteries. Any breakdown or malfunction is signaled by LED on the front panel, and by internal acoustic signal for specific cases. There are three ways to reset alarm or breakdown signal: by a button located near the central unit, or by two other buttons of the front panel, one of which can be activated with key only.

### Technical data

|                                |  |
|--------------------------------|--|
| model                          | 52002  |
| primary power supply           | 230V AC, 100mA, 50-60Hz                              |
| auxiliary power supply         | 2 batteries, 12V DC - 1,1 ÷ 1,3 Ah                   |
| „I“ current                    | min. 264mA ÷ max. 424mA                              |
| maximum output current battery | 300mA  |
| buffer battery charger output  | 24V DC (27.6V DC)                                    |
| protection rating              | IP30   |
| operational temperature        | -5°C ÷ +40°C   |
| operational zones              | single zone (mono-zone)                              |
| acoustic alarm                 | internal buzzer                                      |
| „low battery“ signal           | intermittent internal buzzer                         |
| CE certification               | 0051-CPD-0264  |
| conformity with standards      | EN 54-2 +A1:2006<br>EN 54-4:1997 + A1:2002 + A1:2006 |

## BUFFER BATTERIES

Pair of rechargeable buffer batteries, 12V DC - 1.2Ah

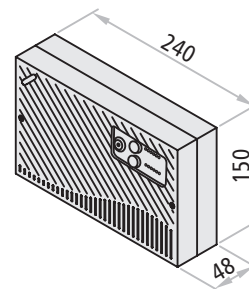

### ATTENTION

According to standard EN 54-4, it is obligatory for the mono-zone central unit to be equipped with:

- nr. 1 heat/smoke detector RFC certif. EN 54-7
- nr. 1 pair of buffer batteries
- nr. 1 external electronic siren certif. EN 54-3
- nr. 1 alarm activation button certif. EN 54/11
- nr. 1 fire/failure alarm deactivation button

### MANAGES

- max. nr. 8 RFC heat/smoke detectors
- max. nr. 5 alarm activation buttons
- max. nr. 2 electronic sirens
- nr. 4 EM or EMP or EMfr electromagnets
- nr. 2 buffer batteries



# Door-holding systems

For fire doors and gates

## RFC HEAT AND SMOKE DETECTOR

Certified in accordance with EN 54-7 standard. RFC heat and smoke detector characterized by white ABS casing. Optical/thermic operation with intervention temperature to be set between 54 and 65°C. To ensure proper functioning, the detectors must be subjected to regular 6-month maintenance checks. Please note that it is inadvisable to position the sensor where strong air currents are present.

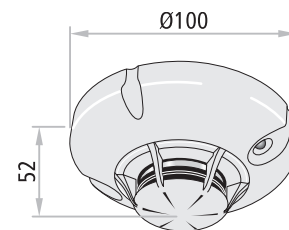

### Technical data

|                                |                               |
|--------------------------------|-------------------------------|
| operational voltage            | 11 ÷ 33V DC, typically 24V DC |
| consumption at rest, at 24V DC | 67µA                          |
| absorption of alarm at 24V DC  | 45mA                          |
| operational temperature        | -20°C ÷ +70°C                 |
| conformity with standards      | EN 54-7                       |

## ELECTRONIC SIREN

In red color ABS, includes a volume control function for installation in internal and external environments. The connection is made using double clamps (6) for branching. With 28 or 32 selectable tones and a second tone for two-phase alarms.

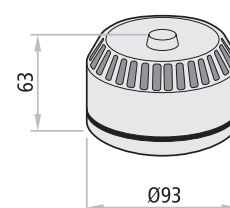

### Technical data

|                               |               |
|-------------------------------|---------------|
| power supply                  | 9 ÷ 28V DC    |
| absorption by alarm at 12V DC | 8mA           |
| absorption by alarm at 24V DC | 16mA          |
| protection rating             | IP65          |
| operational temperature       | -25°C ÷ +70°C |
| conformity with standard      | EN 54-3       |

## ALARM ACTIVATION BUTTON

In red color ABS with a weight of 110 gr. Pressure on the plastic front plate activates the electrical contact. Re-arming of the contact is executed manually using a key (provided).

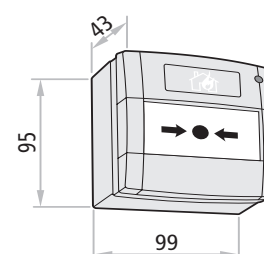

### Technical data

|                           |             |
|---------------------------|-------------|
| power supply              | max. 30V DC |
| protection rating         | IP41        |
| operational temperature   | max. +65°C  |
| internal exchange contact | n.o./n.c.   |
| conformity with standard  | EN 54-11    |

# Door-holding systems

For fire doors and gates



ACCESSORIES  
doors

## ELECTROMAGNETS

### EM and EMfr wall mounted

EM and EMfr wall electromagnet with white plastic casing, consisting of a galvanized metal core, both complete with unlock button. Anchor consisting of a nickel-plated plate and jointed baseboard.

EMfr wall mounted electromagnet differs from the normal EM by allowing to adjust the holding force of the door from 10 to 50 kg (the adjustment is via a trimmer). Emfr electromagnet is recommended for applications on inconsistent walls, in particular those made with plasterboard panels, avoiding potential damage to the electromagnet fixing system (rooting of the dowels).

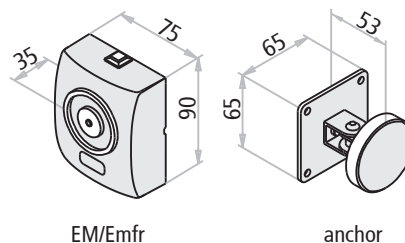

### EMP floor mounted

EMP floor electromagnets consisting of a galvanized metal core, both complete with unlock button. Anchor consisting of a nickel-plated plate and jointed baseboard.

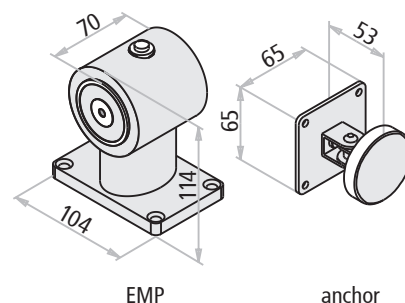

#### Technical data EM - EMP

|                           |  |
|---------------------------|--|
| power supply              | 24Vcc                                  |
| absorption                | 60mA                                   |
| force                     | EM and EMP: 50kg - EMfr: 10 ÷ 50 kg    |
| CE certification          | 0407-CPD-011 (IG-098-2004)/04          |
| conformity with standard  | EN 1155                                |
| anti-magnetism (residual) | pivot on the body of the electromagnet |
| anti-interference         | connector with varistore               |

**"safety is in  
your hands"**





## **Emergency handles Panic bars**

|   |           |
|---|-----------|
| PROVISIONS / STANDARDS                          | 154- 158  |
| EMERGENCY EXIT HANDLES                          | 159 - 167 |
| EXUS - PRESENTATION, FEATURES, CERTIFICATION    | 168 - 173 |
| TWIST - PRESENTATION, FEATURES, CERTIFICATION   | 174 - 177 |
| SLASH - PRESENTATION, FEATURES, CERTIFICATION   | 178 - 183 |
| GENERAL INFORMATION - TECH DRAWINGS, VARIATIONS | 184- 187  |

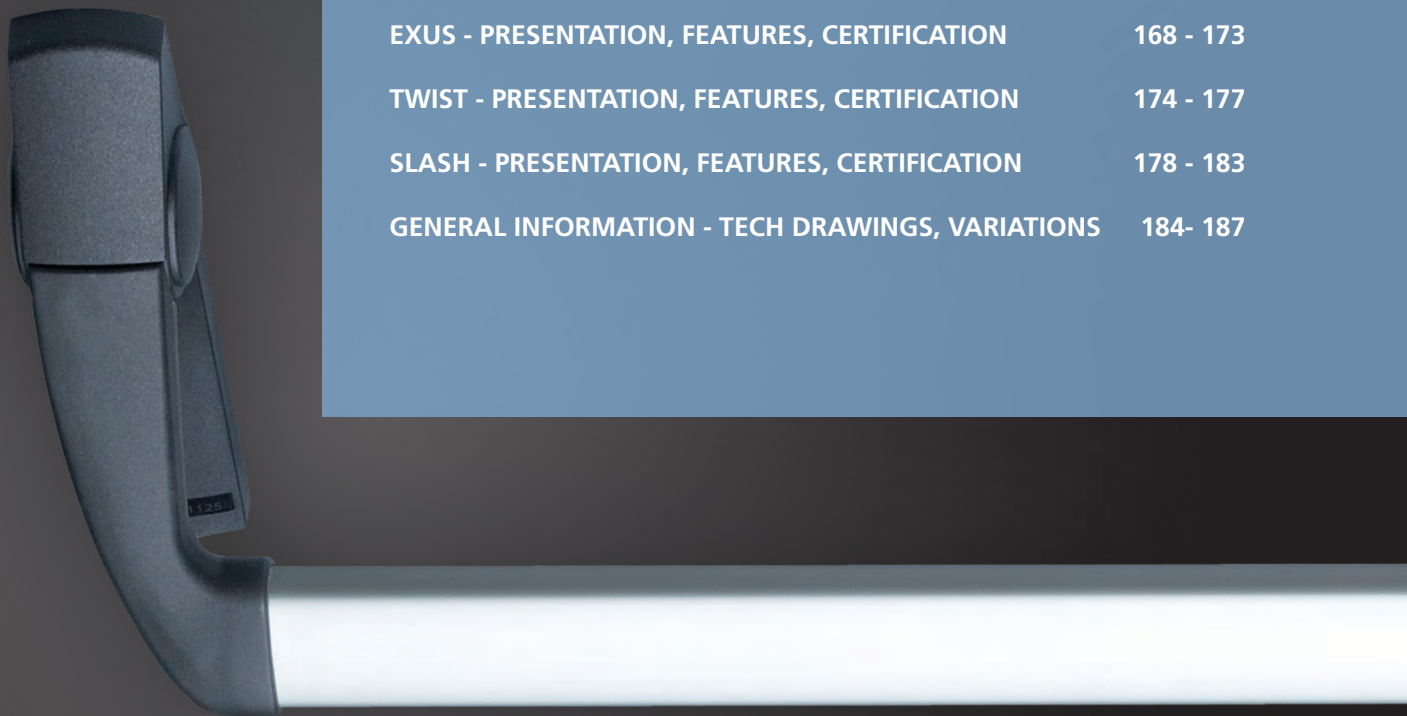

# Provisions/Standards

For emergency exit devices / Anti-panic devices for escape routes

**NINZ**<sup>®</sup>  
FIRE DOORS

## EN 1125:2008 AND EN 179:2008 STANDARDS

New European standards for CE marked safety exit and emergency exit devices entered into effect on 01 January 2010, replacing the previous EN 1125: 1997 + A1:2001 and EN 179:1997 standards.

Standard EN 1125: 2008 specifies the requirements for manufacturing, performance levels and testing of anti-panic exit devices activated mechanically by a horizontal bar and designed for specific use in panic situations along escape routes.

Standard EN 179: 2008 specifies the requirements for the manufacturing, performance levels and testing of emergency exit devices activated mechanically by a lever handle or push panel.

CE conformity of the anti-panic and emergency exit devices with the standard requirements must be demonstrated by initial type testing and production controls carried out by the manufacturer under the continuous observation of the certifying body.

### Performance and safety requirements

- Device selection depends on the risk analysis of its use when installed along escape routes or emergency exits.
- Anti-panic devices are only required to conform with standard EN 1125, permitting exit at any time by a single operation on the horizontal bar that requires no prior knowledge of how the device functions and that permits opening even when the door is subjected to a load. These requirements simulate the forces that could be applied by people who are in a state of panic.
- Standard EN 179 concerns emergency devices designated for use in emergency situations involving people who are accustomed to using safety exits and their devices, and who are therefore unlikely to be taken by panic.
- Devices for anti-panic or emergencies must be designed so that the door can be opened from the inside at any time in less than 1 second.
- Materials used for anti-panic exit devices must remain operational at temperatures between -10° and + 60°.
- **Verification is required for suitability of use with fire/smoke resistant doors, and this verification may only be received by passing a fire resistance test on both sides of the door in conformity with EN 1634-1.**
- **It is extremely important that anti-panic and emergency devices not be used on fire doors that have a higher fire resistance time than the level for which the device itself has been approved.**
- To reduce the risk of entrapping fingers and/or blocking the device, checks based on visual inspection and measurement with appropriate calipers is prescribed.
- Protrusions and corners that could cause harm to persons must be smoothed down.
- Anti-panic or emergency exit devices that activate upper and lower vertical rods (on the inactive leaf, for instance) must ensure that manipulation of the lower rod does not activate the upper rod.
- The strike box mounted on the floor must not rise higher than 15 mm and must be tapered in the direction of the escape route.
- Periodic lubrication must be possible without requiring disassembly of the device.
- For door mass greater than 200 kg and leaf dimensions greater than 1320 x 2520 mm, additional testing under harsher conditions are required.
- The durability of the device may be classified as grade 6 (100,000 cycles) or grade 7 (200,000 cycles). For inactive leaves, grade 6 corresponds to 10,000 cycles, and for grade 7 - 20,000 cycles.
- The presence of an external door furniture (key, cylinder, lever handle, doorknob, etc.) must not in any way interfere with the activation of the internal anti-panic or emergency device.
- **External door furnitures other than those provided by the anti-panic device manufacturer is not considered to conform with standards.**
- External door furnitures provided by the manufacturer may have either manual or electrical operation (e.g., electric handle or lock activated electrically by the handle).
- The material used to make the device must not contain or release dangerous substances in greater amounts than prescribed by European standards or national regulations.
- Anti-panic and emergency exit devices must be accompanied by clear, detailed instructions for installation

# Provisions/Standards

For emergency exit devices / Anti-panic devices for escape routes



and maintenance, including a list of all of the elements that have been tested and approved for use of the device and that could be provided separately.

- **It is essential for anti-panic and emergency exit devices to be installed according to the manufacturer's instructions using duly compatible components only.**
- Horizontal bars and levers must normally be installed at a height range of 900 to 1100 mm above the finished floor level, as measured in the closed position. If it is known that children represent the majority of the rooms' occupants, a reduction in bar height should be considered.
- Once the installation is complete, the force required on the horizontal bar to release the lock must be measured, using a force gauge. Actual measured forces must be reported on the maintenance registry in the installation instructions. The installation instructions should be handed over to the user, who must preserve them for use during maintenance operations.
- **To ensure that performance conforms with certifications, regular maintenance checks need to be carried out at intervals of one month or less, with periodic checks that all of the system's components still correspond to the component list provided at the outset.**

## OFFICIAL GAZETTE OF THE EUROPEAN UNION 04 JULY 2009

### Information from member states:

Commission communication in the context of the application of Directive 89/106/CEE of the Council in relation to the approach of regulatory and administrative legislative provisions of Member States in regards to construction products.

| OEN<br>(1) | Reference and title of the standard  | Reference of<br>the substitute<br>standard           |
|------------|--|--|
|            | EN 1125:2008 Lock accessories  |  |
| CEN        | Anti-panic devices for escape routes activated by horizontal bar - Test methods and requirements | EN 1125/1997   |
|            | EN 179:2008 Lock accessories   |  |
| CEN        | Emergency exit devices activated by lever handles or push plates                                 | EN 179/1997  |
|            | <b>Date of the standard's entry into effect as a harmonized European standard</b>                | <b>Date of expiration of the co-existence period</b> |
|            | 1.1.2009   | 1.1.2010   |

## CE MARKING ACCORDING TO EN 179:2008

How to read the CE marking:

|  |   |          |          |          |          |          |          |          |          |          |     |     |     |     |     |     |     |     |     |      |                        |
|--|---|----------|----------|----------|----------|----------|----------|----------|----------|----------|-----|-----|-----|-----|-----|-----|-----|-----|-----|------|------------------------|
|  | CE conformity marking consisting of the "CE" symbol indicated in Directive 93/68/CE |          |          |          |          |          |          |          |          |          |     |     |     |     |     |     |     |     |     |      |                        |
| <b>M3 device for emergency exits</b>   | Product description   |          |          |          |          |          |          |          |          |          |     |     |     |     |     |     |     |     |     |      |                        |
| <b>Ninz S.p.A. Corso Trento, 2/A I-38061 ALA (TN)/ITALY</b>  | Name or identifying mark and registered address of the manufacturer                 |          |          |          |          |          |          |          |          |          |     |     |     |     |     |     |     |     |     |      |                        |
| <b>10</b>  | Last two digits of the year when the marking was applied                            |          |          |          |          |          |          |          |          |          |     |     |     |     |     |     |     |     |     |      |                        |
| <b>EN 179:2008</b>   | Standard number   |          |          |          |          |          |          |          |          |          |     |     |     |     |     |     |     |     |     |      |                        |
| <b>0425</b>  | Identification number for the certifying body                                       |          |          |          |          |          |          |          |          |          |     |     |     |     |     |     |     |     |     |      |                        |
| <b>0425-CPR-002147</b>   | CE certification number   |          |          |          |          |          |          |          |          |          |     |     |     |     |     |     |     |     |     |      |                        |
| <table border="1"> <tr> <td><b>3</b></td><td><b>7</b></td><td><b>7</b></td><td><b>B</b></td><td><b>1</b></td><td><b>4</b></td><td><b>4</b></td><td><b>2</b></td><td><b>A</b></td><td><b>A</b></td> </tr> <tr> <td>1st</td><td>2nd</td><td>3rd</td><td>4th</td><td>5th</td><td>6th</td><td>7th</td><td>8th</td><td>9th</td><td>10th</td> </tr> </table> | <b>3</b>  | <b>7</b> | <b>7</b> | <b>B</b> | <b>1</b> | <b>4</b> | <b>4</b> | <b>2</b> | <b>A</b> | <b>A</b> | 1st | 2nd | 3rd | 4th | 5th | 6th | 7th | 8th | 9th | 10th | Product classification |
| <b>3</b>   | <b>7</b>  | <b>7</b> | <b>B</b> | <b>1</b> | <b>4</b> | <b>4</b> | <b>2</b> | <b>A</b> | <b>A</b> |          |     |     |     |     |     |     |     |     |     |      |                        |
| 1st  | 2nd   | 3rd      | 4th      | 5th      | 6th      | 7th      | 8th      | 9th      | 10th     |          |     |     |     |     |     |     |     |     |     |      |                        |

## CLASSIFICATION ACCORDING TO EN 179:2008

How to read the classification:

### Category of use (1st character)

Only one category of use is applicable:

- grade 3: very frequent use with little need to pay attention, in the sense of the possibility of accidents or improper use

### Durability (2nd character)

Two different durability ratings are applicable:

- grade 6: 100,000 test cycles
- grade 7: 200,000 test cycles

### Mass of the door (3rd character)

Three different grades of door mass are applicable:

- grade 5: up to 100 kg
- grade 6: up to 200 kg
- grade 7: over 200 kg

### Suitability for use with fire/smoke rated doors (4th character)

Three different grades are applicable:

- grade 0: non approved for use on fire/smoke rated doors;
- grade A: suitable for use on smoke rated doors
- grade B: suitable for use on fire/smoke rated doors; on the basis of testing in conformity with EN 1634-1

### Human safety (5th character)

Only a single human safety rating is applicable:

- grade 1: all devices for panic exits must ensure human safety, so for purposes of the present standard only the maximum rating is allowed

### Corrosion resistance (6th character)

The two different corrosion resistance ratings indicated in EN 1670:2007 are applicable:

- grade 3: 96 h (high resistance)
- grade 4: 240 h (extra-high resistance)

### Material safety (7th character)

Five different material safety grades are applicable:

- grade 2: 1000N
- grade 3: 2000N
- grade 4: 3000N
- grade 5: 5000N

### Protrusion of horizontal bar (8th character)

Two different grades of device protrusion are applicable:

- grade 1: protrusion up to 150 mm (extra protrusion)
- grade 2: protrusion up to 100 mm (standard protrusion)

### Activation type (9th character)

Two activation types are applicable:

- type A: emergency exit device with lever handle activation
- type B: emergency exit device with push panel activation (SLASH, for example)

### Field of door application (10th character)

Four different categories of field of door application are applicable, depending on the final use of the emergency exit device:

- category A: one-leaved door, two-leaved door: active or inactive leaf, push opening
- category B: only one-leaved doors, push opening
- category C: two-leaved doors, inactive leaf only, push opening
- category D: one-leaved doors only, pull opening

# Provisions/CE marking

Panic devices for escape routes



## CE MARKING ACCORDING TO EN 1125:2008-EC1:2009

How to read the CE marking:

|  |   |          |          |          |          |          |          |          |          |          |     |     |     |     |     |     |     |     |     |      |                        |
|--|---|----------|----------|----------|----------|----------|----------|----------|----------|----------|-----|-----|-----|-----|-----|-----|-----|-----|-----|------|------------------------|
|  | CE conformity marking consisting of the "CE" symbol indicated in Directive 93/68/CE |          |          |          |          |          |          |          |          |          |     |     |     |     |     |     |     |     |     |      |                        |
| <b>EXUS Panic exit device</b>  | Product description   |          |          |          |          |          |          |          |          |          |     |     |     |     |     |     |     |     |     |      |                        |
| <b>Ninz S.p.A. Corso Trento, 2/A I-38061 ALA (TN)/ITALY</b>  | Name or identifying mark and registered address of the manufacturer                 |          |          |          |          |          |          |          |          |          |     |     |     |     |     |     |     |     |     |      |                        |
| <b>08</b>  | Last two digits of the year when the marking was applied                            |          |          |          |          |          |          |          |          |          |     |     |     |     |     |     |     |     |     |      |                        |
| <b>EN 1125:2008-EC1:2009</b>   | Standard number   |          |          |          |          |          |          |          |          |          |     |     |     |     |     |     |     |     |     |      |                        |
| <b>0425</b>  | Identification number for the certifying body                                       |          |          |          |          |          |          |          |          |          |     |     |     |     |     |     |     |     |     |      |                        |
| <b>0425-CPR-001228</b>   | CE certification number   |          |          |          |          |          |          |          |          |          |     |     |     |     |     |     |     |     |     |      |                        |
| <table border="1"> <tr> <td><b>3</b></td><td><b>7</b></td><td><b>7</b></td><td><b>B</b></td><td><b>1</b></td><td><b>3</b></td><td><b>2</b></td><td><b>1</b></td><td><b>A</b></td><td><b>A</b></td> </tr> <tr> <td>1st</td><td>2nd</td><td>3rd</td><td>4th</td><td>5th</td><td>6th</td><td>7th</td><td>8th</td><td>9th</td><td>10th</td> </tr> </table> | <b>3</b>  | <b>7</b> | <b>7</b> | <b>B</b> | <b>1</b> | <b>3</b> | <b>2</b> | <b>1</b> | <b>A</b> | <b>A</b> | 1st | 2nd | 3rd | 4th | 5th | 6th | 7th | 8th | 9th | 10th | Product classification |
| <b>3</b>   | <b>7</b>  | <b>7</b> | <b>B</b> | <b>1</b> | <b>3</b> | <b>2</b> | <b>1</b> | <b>A</b> | <b>A</b> |          |     |     |     |     |     |     |     |     |     |      |                        |
| 1st  | 2nd   | 3rd      | 4th      | 5th      | 6th      | 7th      | 8th      | 9th      | 10th     |          |     |     |     |     |     |     |     |     |     |      |                        |

## CLASSIFICATION ACCORDING TO EN 1125:2008

How to read the classification:

### Category of use (1st character)

There is only one category of use that may be utilized:

- grade 3: very frequent use with little need to pay attention, in the sense of the possibility of accidents or improper use

### Durability (2nd character)

Two different durability ratings are applicable:

- grade 6: 100,000 test cycles
- grade 7: 200,000 test cycles

### Mass of the door (3rd character)

Three different grades of door mass are applicable:

- grade 5: up to 100 kg
- grade 6: up to 200 kg
- grade 7: over 200 kg

### Suitability for use with fire/smoke resistant doors (4th character)

Three different grades are applicable:

- grade 0: non approved for use on fire/smoke resistant doors
- grade A: suitable for use on smoke resistant doors
- grade B: suitable for use on fire/smoke resistant doors; on the basis of testing in conformity with EN 1634-1

### Human safety (5th character)

Only a single human safety rating are applicable:

- grade 1: all devices for panic exits must ensure human safety, so that for purposes of the present standard only the maximum rating is allowed

### Corrosion resistance (6th character)

The two different corrosion resistance ratings indicated in EN 1670:2007 are applicable:

- grade 3: 96 h (high resistance)
- grade 4: 240 h (extra-high resistance)

### Material safety (7th character)

Only a single material safety rating are applicable:

- grade 2: there is only one category that represents the minimum obtainable rating due to the fact that material safety must be viewed as secondary relative to human safety

### Protrusion of horizontal bar (8th character)

Two different grades of horizontal bar protrusion are applicable:

- grade 1: protrusion up to 150 mm (extra protrusion)
- grade 2: protrusion up to 100 mm (standard protrusion)

### Horizontal bar activation type (9th character)

Two activation types are applicable:

- type A: panic bars with push-bar activation (EXUS and TWIST, for example)
- type B: panic bars with touch-bar activation (SLASH, for example)

### Field of door application (10th character)

Three different categories of field of door application are applicable, depending on the final use of the panic exit device:

- category A: one-leaved door, two-leaved door: active or inactive leaf, push opening
- category B: only one-leaved doors, push opening
- category C: two-leaved doors, inactive leaf only, push opening

## TESTING EQUIPMENT

Our company maintains its own testing and experimentation equipment in order to ensure maximum quality, reliability and innovative service to our customers.



Company furnace



Mechanical testing equipment



Operational testing equipment

# Emergency handles

NINZ

**NINZ**<sup>®</sup>  
FIREDOORS

DEVICES

## PRESENTATION

### Emergency exit devices (emergency handles)

Ninz S.p.A. is a leader in fire doors, and has once again re-asserted itself as a visionary company with a strong identity created by its continuous research into the design and technology of its own products, such as the new line of emergency exit handles.

The handles are **CE** marked and pre-certified according to European standard EN 179:2008, which entered in effect January 01, 2010, and which prescribes a several substantial changes that further extend the requirements for maximum safety and ease of opening.

### The Kit designed for your needs

When ordered separately from the door, the M3, M3X, M14, M14X, Hot CIL and HOT CIL-X handles are packaged in functional KITS for display and presentation in the most appropriate distribution context.

Packaging in KITS ensures customers, installers and therefore the final users that they are receiving a complete anti-panic system with fully corresponding and **CE** certified parts.

### Certifications and replacements

Given the importance of maintaining the entire system's **CE** conformity, special attention has been paid to replacement parts, which have been subjected to testing in accordance with the EN 179:2008 standard due to their pivotal role in maintaining **CE** certification.

The only way to ensure that the products maintain their original characteristics over time is by using original NINZ replacement parts.

For this reason, the instructions for emergency handles include additional indications regarding proper installation and maintenance plus a exploded assembly drawing that specifies every smallest detail of the certified system with all of the references required for ordering replacement parts.



# M3 and M3tir emergency handle

Emergency handle for internal locks - EN 179:2008

**NINZ**<sup>®</sup>  
FIREDOORS

## M3 AND M3tir IN BLACK PLASTIC

### Description

Lever handle for emergency exit:

- Reversible for right or left opening
- Applicable to single leaf doors or the active leaf (main leaf) of two-leaved doors located at emergency exits
- Suitable for Rever/Univer/Proget doors and other types of emergency exit doors
- Both the levers and the cover plates are made of black plastic, and the core of the lever and the installation plate are made of galvanized steel
- The lock is anti-panic/fire rated for European profile cylinders
- Cylinder to pass in nickel-plated brass with 3 keys
- Suitable for doors with dimensions up to 1350 x 2880mm/leaf, mass up to 300kg/leaf, with ratings up to EI,120 - REI120 and smoke resistance, handle protrusion of 67mm

### Use

The M3 and M3tir emergency exit handles are to be applied on doors designated for emergency situations involving people who are accustomed to using safety exits and their hardware, and who are therefore unlikely to be in a state of panic.

### Operating mode

In the M3 version, with the lock locked by key, the door can no longer be opened from the pull side, while the door can still be opened using the lever on the push side, in the M3tir version the door can no longer be opened from the side to push, while on the side to pull the opening is always possible by acting on the handle. The passive (secondary) leaf normally remains closed and is only opened manually by a deadbolt lock (019).

## VERSIONS AVAILABLE

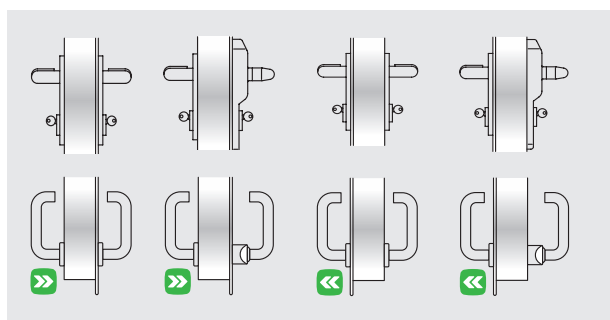

M3

M3 ELM/mt  
M3 ELM/fs

M3tir

M3tir ELM/mt  
M3tir ELM/fs

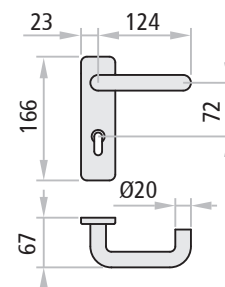

## SUPPLIED TOGETHER WITH THE DOOR

For single leaf or the active leaf of two-leaved doors:

*Included (mounted on the door):* anti-panic lock with 65mm entrance and the strike box insert.

*Included (in the package):* Nr. 2 black plastic lever handles, Nr. 2 galvanized steel installation plates, Nr. 2 black plastic cover plates, Nr. 1 split square spindle, Nr. 1 standard nickel-plated cylinder to pass with 3 keys, Nr. 1 adhesive pictogram (green arrow), Nr. 1 instruction/maintenance manual.

*Versions available:* M3, M3 ELM/mt, M3 ELM/fs, M3tir ELM/fs, M3tir, M3tir ELM/mt

*ELM electric handle: see the dedicated pages*

## M3 AND M3tir KIT VERSION

(SUPPLIED SEPARATELY FROM THE DOOR)

KIT for single leaf or the active leaf of two-leaved doors:

*KIT contents:* Nr. 1 anti-panic lock with 65mm entrance, Nr. 1 strike box insert, Nr. 2 black plastic lever handles, Nr. 2 galvanized steel installation plates, Nr. 2 black plastic cover plates, Nr. 1 split square spindle, Nr. 1 standard nickel-plated cylinder to pass with 3 keys, Nr. 1 adhesive pictogram (green arrow), Nr. 1 instruction/maintenance manual.

*Versions available:* M3, M3tir

## VARIATIONS ON REQUEST

- MAC1 type panic lock, including access control mode
- Panic lock with 3 closing points (for multipurpose PRO-GET doors only and not available for the M3tir version)
- Mastered or coded cylinders

# M3X and M3Xtir emergency handle

Emergency handle for internal locks - EN 179:2008

**NINZ**  
FIREDOORS

## M3X AND M3Xtir IN STAINLESS STEEL

### Description

Lever handle for emergency exit:

- Reversible for right or left opening
- Applicable to single leaf doors or the active leaf (main leaf) of two-leaved doors located at emergency exits
- Suitable for Rever/Univer/Proget doors and other types of emergency exit doors
- The levers as well as the cover plates are made of AISI 304 brushed stainless steel, and the installation plates are made of galvanized steel
- The lock is anti-panic/fire rated for Euro profile cylinders
- Cylinder to pass in nickel-plated brass with 3 keys
- Suitable for doors with dimensions up to 1350 x 2880mm/leaf, mass up to 300kg/leaf, with fire resistance up to EI<sub>120</sub> - REI120 and smoke resistance, handle protrusion of 67mm

### Use

The M3X and M3Xtir emergency exit handles are to be applied on doors designated for emergency situations in which the people involved are accustomed to using safety exits and their opening devices, and therefore who are very unlikely to be in a state of panic.

### Operating mode

In the M3 version, with the lock locked by key, the door can no longer be opened from the pull side, while the door can still be opened using the lever on the push side, in the M3tir version the door can no longer be opened from the side to push, while on the side to pull the opening is always possible by acting on the handle.

The passive (secondary) leaf normally remains closed and is only opened manually by a deadbolt lock (019).

## VERSIONS AVAILABLE

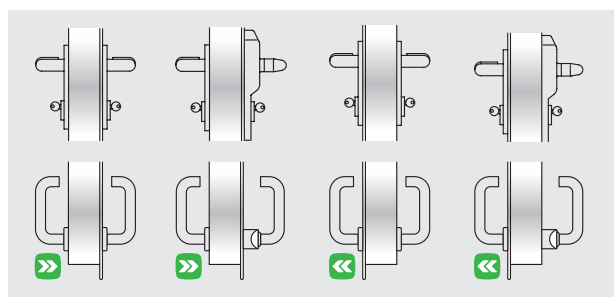

M3X

M3X ELM/mt  
M3X ELM/fs

M3Xtir

M3Xtir ELM/mt  
M3Xtir ELM/fs

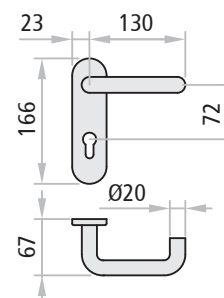

## SUPPLIED TOGETHER WITH THE DOOR

### For single leaf or the active leaf of two-leaved doors:

*Included (mounted on the door):* anti-panic lock with 65mm entrance and the strike box insert.

*Included (in the package):* Nr. 2 lever handles in brushed stainless steel, Nr. 2 galvanized steel installation plates, Nr. 2 cover plates in brushed stainless steel, Nr. 1 split square spindle, Nr. 1 standard nickel-plated cylinder to pass with 3 keys, fastener screws, Nr. 1 adhesive pictogram (green arrow), Nr. 1 instruction/maintenance manual.

*Versions available:* M3X, M3X ELM/mt, M3Xs, M3Xstir, M3X ELM/fs, M3Xtir ELM/fs, M3Xtir, M3Xtir ELM/mt  
ELM electric handle: see the dedicated pages

## M3X KIT VERSION

### (SUPPLIED SEPARATELY FROM THE DOOR)

### KIT for single leaf or the active leaf of two-leaved doors:

*KIT contents:* Nr. 1 anti-panic lock with 65mm entrance, Nr. 1 strike box insert, Nr. 2 lever handles in brushed stainless steel, Nr. 2 galvanized steel installation plates, Nr. 2 cover plates in brushed stainless steel, Nr. 1 split square spindle, Nr. 1 standard nickel-plated cylinder to pass with 3 keys, fastener screws, Nr. 1 adhesive pictogram (green arrow), Nr. 1 instruction/maintenance manual.

*Versions available:* M3X, M3Xs and M3Xstir

## VARIATIONS ON REQUEST

- MAC1 panic lock, including access control system
- Panic lock with 3 closing points (for multipurpose PRO-GET doors only and not available for the M3tir version)
- Mastered or coded cylinders

# Certifications

Emergency handle for internal locks - EN 179:2008



DEVICES

## M3, M3X CERTIFICATIONS

Suitable for one-leaved doors or the active leaf of two-leaved doors with dimensions up to 1350x2880 mm/leaf and a mass up to 300 kg/leaf.

|                                     |  |
|-------------------------------------|--|
| <b>CE</b>                           |  |
| <b>Denominazione</b>                | M3, M3X DEVICE FOR EMERGENCY EXITS                   |
| <b>Manufacturer</b>                 | Ninz S.p.A. Corso Trento, 2/A I-38061 ALA (TN)/ITALY |
| <b>Year application trademark</b>   | 10   |
| <b>Nr. and year of the standard</b> | EN 179:2008  |
| <b>Certifying body</b>              | 0425   |
| <b>CE certificate Nr.</b>           | 2147-CPD-2010  |
| <b>Classification</b>               | <b>3 7 7 B 1 4 4 2 A A</b>                           |

- 1st Category of use very frequent
- 2nd Durability 200.000 cycles
- 3rd Door mass over 200 kg
- 4th Suitable for fire/smoke rated doors
- 5th Safety, suitable for evacuation routes
- 6th High corrosion resistance 240 h
- 7th Material safety 1000 N
- 8th Handle protrusion up to 100 mm
- 9th Activation type with lever handle
- 10th Suitable for one- or two-leaved doors

## M3TIR, M3Xtir CERTIFICATIONS

Suitable for one-leaved doors or two-leaved doors with the second leaf semi-fixed and in any case not provided with emergency or panic device, with dimensions up to 1350x2880 mm/leaf and a mass up to 300 kg/leaf.

|                                    |   |
|------------------------------------|---|
| <b>CE</b>                          |   |
| <b>Denominazione</b>               | M3tir, M3Xtir DEVICE FOR EMERGENCY EXITS              |
| <b>Produttore</b>                  | Ninz S.p.A. Corso Trento, 2/A I-38061 ALA (TN)/ITALIA |
| <b>Anno applicazione marchio</b>   | 10  |
| <b>N° e anno della norma</b>       | EN 179:2008   |
| <b>Organismo di certificazione</b> | 0425  |
| <b>N° del certificato CE</b>       | 0425-CPR-002149                                       |
| <b>Classificazione</b>             | <b>3 7 7 B 1 4 4 2 A D</b>                            |

- 1st Category of use very frequent
- 2nd Durability 200.000 cycles
- 3rd Door mass over 200 kg
- 4th Suitable for fire/smoke rated doors
- 5th Safety, suitable for evacuation routes
- 6th High corrosion resistance 240 h
- 7th Material safety 1000 N
- 8th Handle protrusion up to 100 mm
- 9th Activation type with lever handle
- 10th Suitable for one- or two-leaved doors

**ICIM S.p.A. - Identification number: 0425**  
Piazza Don Enrico Mapelli, 75 - 20099 Sesto San Giovanni (MI) - ITALY

### Certificato di costanza delle prestazioni

*Certificate of constancy of performance*

Certificato N. **0425 - CPR - 002147**  
Certificate No.

In conformità al Regolamento 305/2011/UE del Parlamento Europeo e del Consiglio del 9 marzo 2011 (Regolamento Prodotti da Costruzione o CPR), questo certificato si applica al prodotto da costruzione.  
In compliance with Regulation 305/2011/UE of the European Parliament and of the Council of 9 March 2011 (the Construction Products Certification or CPR), this certificate applies to the construction product.

**Dispositivi per uscite di emergenza azionati mediante maniglia a leva o piastra a spinta**  
*Emergency exit devices operated by a lever handle or push pad*

SERIE / SERIES **M3, M3X**  
MODELLI / MODELS See annex

Caratteristiche: vedi Allegato / Characteristics: see Annex  
IMMESSO SUL MERCATO CON IL NOME O IL MARCHIO DI PLACED ON THE MARKET UNDER THE NAME OR TRADE MARK OF  
**NINZ S.p.A.**

SEDE LEGALE / HEAD OFFICE **Corso Trento, 2/A 38061 ALA (TN) - IT**  
UNITÀ OPERATIVA / PRODUCTION UNIT **Corso Trento, 2/A 38061 ALA (TN) - IT**

Questo certificato attesta che tutte le disposizioni riguardanti la valutazione e la verifica della costanza della prestazione e le prestazioni descritte nell'allegato ZA della norma.  
This certificate attests that all provisions concerning the assessment and verification of constancy of performance and the performances described in Annex ZA of the standard.

**EN 179:2008**  
nell'ambito del sistema 1 di cui al presente certificato vengono applicati e che il controllo di produzione in fabbrica condotto dal produttore è validato al fine di garantire la conformità del sistema 1 set out in this certificate are applied and that the factory production control conducted by the manufacturer is assessed to ensure the

**COSTANZA DELLA PRESTAZIONE DEL PRODOTTO DA COSTRUZIONE**  
*CONSTANCY OF PERFORMANCE OF THE CONSTRUCTION PRODUCT*

Questo certificato è stato emesso per la prima volta il 12/03/2010 e ha validità sino a che la norma armonizzata, il prodotto da costruzione, i metodi ACVP o le condizioni di produzione nello stabilimento non subiscano modifiche significative, o sino a che non venga sospeso o ritratto dall'organismo di certificazione notificato ICIM S.p.A.  
This certificate was first issued on 12/03/2010 and will remain valid as long as neither the harmonized standard, the construction product, the ACVP methods nor the manufacturing conditions in the plant are modified significantly, unless suspended or withdrawn by the notified product certification body ICIM S.p.A.

Il presente Certificato è da ritenersi valido solo se accompagnato dal relativo Allegato / This Certificate is valid only with the relative Annex

**ICIM S.p.A.**  
EMMISSIONE / ISSUE  
**12/03/2020**

ICIM S.p.A. - Piazza Don Enrico Mapelli, 75 - 20099 Sesto San Giovanni (MI)

**ICIM S.p.A. - Identification number: 0425**  
Piazza Don Enrico Mapelli, 75 - 20099 Sesto San Giovanni (MI) - ITALY

### Certificato di costanza delle prestazioni

*Certificate of constancy of performance*

Certificato N. **0425 - CPR - 002149**  
Certificate No.

In conformità al Regolamento 305/2011/UE del Parlamento Europeo e del Consiglio del 9 marzo 2011 (Regolamento Prodotti da Costruzione o CPR), questo certificato si applica al prodotto da costruzione.  
In compliance with Regulation 305/2011/UE of the European Parliament and of the Council of 9 March 2011 (the Construction Products Certification or CPR), this certificate applies to the construction product.

**Dispositivi per uscite di emergenza azionati mediante maniglia a leva o piastra a spinta**  
*Emergency exit devices operated by a lever handle or push pad*

SERIE / SERIES **M3 tir, M3X tir**  
MODELLI / MODELS See annex

Caratteristiche: vedi Allegato / Characteristics: see Annex  
IMMESSO SUL MERCATO CON IL NOME O IL MARCHIO DI PLACED ON THE MARKET UNDER THE NAME OR TRADE MARK OF  
**NINZ S.p.A.**

SEDE LEGALE / HEAD OFFICE **Corso Trento, 2/A 38061 ALA (TN) ITALY**  
UNITÀ OPERATIVA / PRODUCTION UNIT **Corso Trento, 2/A 38061 ALA (TN) ITALY**

Questo certificato attesta che tutte le disposizioni riguardanti la valutazione e la verifica della costanza della prestazione e le prestazioni descritte nell'allegato ZA della norma.  
This certificate attests that all provisions concerning the assessment and verification of constancy of performance and the performances described in Annex ZA of the standard.

**EN 179:2008**  
nell'ambito del sistema 1 di cui al presente certificato vengono applicati e che il controllo di produzione in fabbrica condotto dal produttore è validato al fine di garantire la conformità del sistema 1 set out in this certificate are applied and that the factory production control conducted by the manufacturer is assessed to ensure the

**COSTANZA DELLA PRESTAZIONE DEL PRODOTTO DA COSTRUZIONE**  
*CONSTANCY OF PERFORMANCE OF THE CONSTRUCTION PRODUCT*

Questo certificato è stato emesso per la prima volta il 28/04/2010 e ha validità sino a che la norma armonizzata, il prodotto da costruzione, i metodi ACVP o le condizioni di produzione nello stabilimento non subiscano modifiche significative, o sino a che non venga sospeso o ritratto dall'organismo di certificazione notificato ICIM S.p.A.  
This certificate was first issued on 28/04/2010 and will remain valid as long as neither the harmonized standard, the construction product, the ACVP methods nor the manufacturing conditions in the plant are modified significantly, unless suspended or withdrawn by the notified product certification body ICIM S.p.A.

Il presente Certificato è da ritenersi valido solo se accompagnato dal relativo Allegato / This Certificate is valid only with the relative Annex

**ICIM S.p.A.**  
Direttore Tecnico  
EMMISSIONE / ISSUE  
**15/12/2016**

ICIM S.p.A. - Piazza Don Enrico Mapelli, 75 - 20099 Sesto San Giovanni (MI)

# HOT-CIL emergency handle

Emergency handle for internal locks - EN 179:2008

**NINZ**  
FIREDOORS

## HOT-CIL IN BLACK PLASTIC

### Description

Lever handle and fixed doorknob for emergency exits, especially for hotel rooms:

- Reversible for right or left opening
- Normally applied on single leaf doors or the active leaf of two-leaved doors if the inactive leaf normally remains closed and can only be opened manually with the latch bolt (019)
- Suitable for Rever/Univer/Proget doors and other types of emergency exit pull doors
- The lever, doorknob and even the cover plates are made of black plastic, while the core of the lever and the installation plates are made of galvanized steel
- The lock is anti-panic/fire rated pull type for Euro profile cylinders
- Mastered cylinder to pass with thumbturn latch on the pull side made of nickel-plated brass with 3 keys
- Suitable for doors with dimensions up to 1350 x 2880mm/leaf, mass up to 300kg/leaf, with fire rating EI<sub>2</sub>120 - REI120 and smoke resistance, handle protrusion of 67mm

### Use

The HOT-CIL emergency exit handle is to be applied on doors designated for emergency situations in which the people involved are accustomed to using safety exits and their opening devices, and who are therefore very unlikely to be in a state of panic.

### Operating mode

The door can be opened from the push side by key only, while it can be opened at any time from the pull side by pressing the handle, even when the lock is locked using the key. The lock has two bolts that protrude when the key or the thumbturn latch is turned.

## VERSIONS AVAILABLE

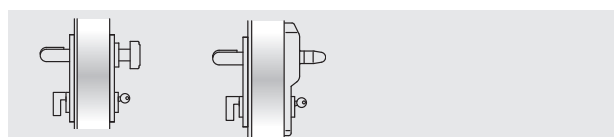

HOT-CIL

HOT-CIL ELM/mt  
HOT-CIL ELM/fs

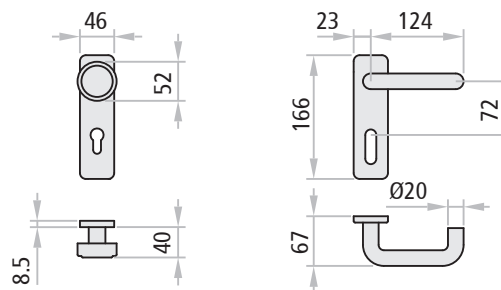

## SUPPLIED TOGETHER WITH THE DOOR

For the single leaf or active leaf of two-leaved doors (the inactive leaf normally remains closed and can only be opened manually using the bolt lock (019)):

*Included (mounted on the door):* the anti-panic lock with 65mm entrance and the strike box insert.

*Included (in the package):* Nr. 1 lever handle and Nr. 1 fixed doorknob in black plastic, Nr. 2 galvanized steel installation plates, Nr. 2 black plastic cover plates, Nr. 1 square spindle, Nr. 1 mastered cylinder with thumbturn latch on the pull side made of nickel-plated brass with 3 keys, fastener screws, Nr. 1 adhesive pictogram (green arrow), Nr. 1 set of instructions for installation/maintenance.

*Versions available:* HOT-CIL, HOT-CIL ELM/mt, HOT-CIL ELM/fs

*ELM electric handle:* see the dedicated pages.

## HOT-CIL KIT VERSION

### (SUPPLIED SEPARATELY FROM THE DOOR)

KIT for single leaf or the active leaf of two-leaved doors (the inactive leaf normally remains closed and can only be opened manually using the bolt lock (019)):

*KIT contents:* Nr. 1 anti-panic lock with 65mm entrance, Nr. 1 strike box insert, Nr. 1 lever handle and Nr. 1 fixed doorknob in black plastic, Nr. 2 galvanized steel installation plates, Nr. 2 black plastic cover plates, Nr. 1 square spindle, Nr. 1 mastered cylinder with thumbturn latch on the pull side made of nickel-plated brass with 3 keys, fastener screws, Nr. 1 adhesive pictogram (green arrow), Nr. 1 set of instructions for installation/maintenance.

*Versions available:* HOT-CIL

# HOT-CIL-X emergency handle

Emergency handle for internal locks - EN 179:2008

**NINZ**<sup>®</sup>  
FIREDOORS

## HOT-CIL-X IN STAINLESS STEEL

### Description

Lever handle and fixed doorknob for emergency exits, especially for hotel rooms:

- Lever handle and fixed doorknob for emergency exits, especially for hotel rooms:
- Reversible for right or left opening
- Normally applied on single leaf doors or the active leaf of two-leaved doors if the inactive leaf normally remains closed and can only be opened manually with the latch bolt (019)
- Suitable for Rever/Univer/Proget doors and other types of emergency exit pull doors
- The lever, doorknob and cover plates are made of AISI 304 brushed stainless steel, while the installation plates are made of galvanized steel
- The lock is anti-panic/fire rated for Euro profile cylinders
- Mastered cylinder to pass with thumbturn latch on the pull side made of nickel-plated brass with 3 keys
- Suitable for doors with dimensions up to 1350x 2880mm/ leaf, mass up to 300kg/leaf, fire rated to EI,120 - REI120 and smoke resistance, handle protrusion of 67mm

### Use

The HOT-CIL-X emergency exit handle is for use on doors designated for emergency situations in which the people involved are accustomed to using safety exits and their opening devices, and who are therefore very unlikely to be in a state of panic.

### Operating mode

The door can be opened from the push side by key only, while it can be opened at any time from the pull side by pressing the handle, even when the lock is locked using the key. The lock has two bolts that protrude when the key or the thumbturn latch is turned.

## VERSIONS AVAILABLE

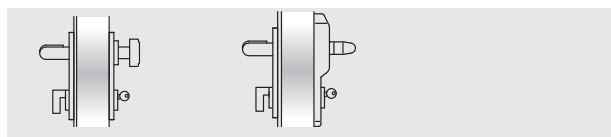

HOT-CIL-X

HOT-CIL-X ELM/mt

HOT-CIL X ELM/fs

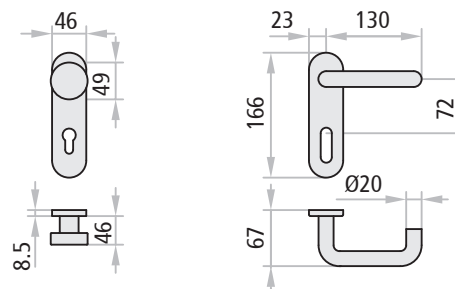

## SUPPLIED TOGETHER WITH THE DOOR

For the single leaf or active leaf of two-leaved doors (the inactive leaf normally remains closed and can only be opened manually using the bolt lock (019)):

*Included (mounted on the door):* the anti-panic lock with 65mm entrance and the strike plate insert.

*Included (in the package):* Nr. 1 lever handle and Nr. 1 fixed doorknob in brushed stainless steel, Nr. 2 galvanized steel installation plates, Nr. 2 cover plates in brushed stainless steel, Nr. 1 square spindle, Nr. 1 mastered cylinder with thumbturn latch on the pull side made of nickel-plated brass with 3 keys, fastener screws, Nr. 1 adhesive pictogram (green arrow), Nr. 1 set of instructions for installation/maintenance.

*Versions available:* HOT-CIL-X, HOT-CIL-X ELM/mt, HOT-CIL-X ELM/fs

*ELM electric handle:* see the dedicated pages.

## HOT-CIL-X KIT VERSION

### (SUPPLIED SEPARATELY FROM THE DOOR)

KIT for single leaf or the active leaf of two-leaved doors (the inactive leaf normally remains closed and can only be opened manually using the bolt lock (019)):

*KIT contents:* Nr. 1 anti-panic lock with 65mm entrance, Nr. 1 strike plate insert, Nr. 1 lever handle and Nr. 1 fixed doorknob in brushed stainless steel, Nr. 2 galvanized steel installation plates, Nr. 2 cover plates in brushed stainless steel, Nr. 1 square spindle, Nr. 1 mastered cylinder with thumbturn latch on the pull side made of nickel-plated brass with 3 keys, fastener screws, Nr. 1 adhesive pictogram (green arrow), Nr. 1 set of instructions for installation/maintenance.

*Versions available:* HOT-CIL-X

# Certifications

Emergency handle for internal locks - EN 179:2008



## HOT-CIL, HOT-CIL-X CERTIFICATION

Suitable for one-leaved doors or two-leaved doors with the second leaf semi-fixed and not equipped with emergency or anti-panic devices, with dimensions up to 1350x2880mm/leaf, mass up to 300kg/leaf.

|                                     |   |
|-------------------------------------|---|
| <b>CE</b>                           |   |
| <b>Denomination</b>                 | HOT-CIL, HOT-CIL-X<br>EMERGENCY EXIT DEVICE             |
| <b>Manufacturer</b>                 | Ninz S.p.A. Corso Trento, 2/A<br>I-38061 ALA (TN)/ITALY |
| <b>Year application trademark</b>   | 10  |
| <b>Nr. and year of the standard</b> | EN 179:2008   |
| <b>Certifying body</b>              | 0425  |
| <b>CE certificate Nr.</b>           | 0425-CPR-002149   |
| <b>Classification</b>               | <b>3 7 7 B 1 4 4 2 A D</b>                              |

- 1st Category of use very frequent
- 2nd Durability 200.000 cycles
- 3rd Door mass over 200 kg
- 4th Suitable for fire/smoke rated doors
- 5th Safety, suitable for evacuation routes
- 6th High corrosion resistance 240 h
- 7th Material safety 1000 N
- 8th Handle protrusion up to 100 mm
- 9th Activation type with lever handle
- 10th Suited for one-leaved doors, pull opening

DEVICES



# M14 emergency handle

Emergency handle for insertion in lock - EN 179:2008

## M14 IN BLACK PLASTIC

### Description

Lever handle for emergency exit:

- Reversible for right or left opening
- For application to the inactive leaf of two-leaved doors located at emergency exits
- Suitable for Rever/Univer/Proget doors and other types of emergency exit doors
- The lever and cover plate are both made of black plastic, while the core of the lever and the installation plate are made of galvanized steel (with external installation plate in case of Rever door)
- The safety lock is anti-panic fire rated, activates the vertical rods and ensures automatic closure
- Suitable for doors with dimensions up to 1350x2880mm/leaf, mass up to 300kg/leaf, with fire rating EI<sub>120</sub> - REI<sub>120</sub> and smoke resistance, handle protrusion of 67mm

### Use

The M14 emergency exit handle is to be applied to doors designated for emergency situations in which the people involved are accustomed to using safety exits and their opening devices, and who are therefore highly unlikely to be in a state of panic.

The active (main) leaf must also be equipped with an anti-panic or emergency device.

### Operating mode

The M14 emergency device is always used in combination with a second device for safety or emergency exits that is applied to the active (main) leaf, and for this reason does not include external opening door furnitures.

From the push side, opening is possible at any time by pushing on the handle, which causes the vertical rods to retract and at the same time pulls back the bolt of the active leaf's lock, unlatching both doors.

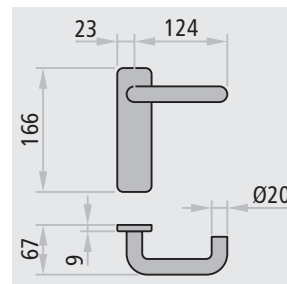

version for Univer/Proget door

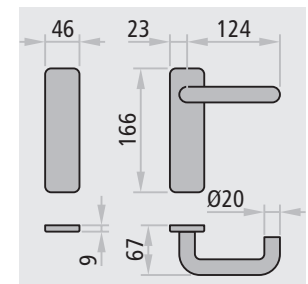

version for Rever door

## SUPPLIED TOGETHER WITH THE DOOR

### For the inactive leaf of two-leaved doors:

*Included (mounted on the door):* anti-panic safety lock with 80mm entrance, vertical rods, upper locking device, upper strike plate.

*Included (in the package):* Nr. 1 black plastic lever handle with galvanized steel installation plate and blank black plastic cover plate (with external installation plate for Rever doors), Nr. 1 square spindle, Nr. 1 floor-mounted floor catch, Nr. 1 carrier arm (for fire doors only), fastener screws, Nr. 1 adhesive pictogram (green arrow), Nr. 1 set of instructions for installation/maintenance.

## M14 KIT VERSION

### (SUPPLIED SEPARATELY FROM THE DOOR)

### KIT for the inactive leaf of two-leaved doors:

Please specify the door type - REVER, UNIVER or PROGET - in the order. *KIT contents:* Nr. 1 anti-panic safety lock with 80mm entrance, Nr. 1 black plastic lever handle with galvanized steel installation plate and blank black plastic cover plate (with external installation plate for Rever doors), Nr. 1 square spindle, Nr. 1 upper locking device (for Rever and Univer multipurpose doors only), Nr. 1 carrier arm (excluding Rever and Univer multipurpose doors), fastener screws, Nr. 1 adhesive pictogram (green arrow), Nr. 1 set of instructions for installation/maintenance.

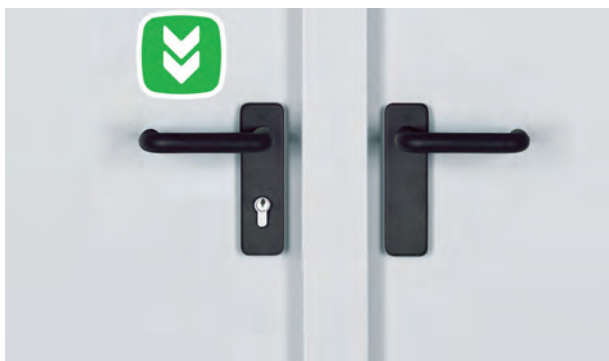

### M3-M14

Two-leaved door emergency exit according to EN 179



### EXUS © LP-M14

According to EN 1125-2008 this is a two-leaved door for emergency exit and a one-leaved door for anti-panic exit

# M14X emergency handle

Emergency handle for internal locks - EN 179:2008



## M14X IN STAINLESS STEEL

### Description

Lever handle for emergency exit:

- Reversible for right or left opening
- For application to the inactive leaf of two-leaved doors located at emergency exits
- Suitable for Rever/Univer/Proget doors and other types of emergency exit doors
- The lever and cover plate are both made of AISI 304 brushed stainless steel, while the installation plate is made of galvanized steel (with external installation plate in case of Rever door)
- The safety lock is anti-panic/fire rated, activates the vertical rods and ensures automatic closure
- Suitable for doors with dimensions up to 1350x2880mm/leaf, mass up to 300kg/leaf, with fire rating EI<sub>2</sub>120 - REI120 and smoke resistance, handle protrusion of 67mm

### Use

The M14X emergency exit handle is to be applied on doors designated for emergency situations in which the people involved are accustomed to using safety exits and their opening devices, and who are therefore highly unlikely to be in a state of panic. The active (main) leaf must also be equipped with an anti-panic or emergency device.

### Operating mode

The M14X emergency device is always used in combination with a second device for safety or emergency exits that is applied to the active leaf, and for this reason does not include external opening door furnitures. From the push side, opening is possible at any time by pushing on the handle, which causes the vertical rods to retract and at the same time pulls back the bolt of the active leaf's lock, unlatching both doors.

## M14, M14X CERTIFICATION

Suited for the inactive leaf of two-leaved doors with dimensions up to 1350x2880mm/leaf, mass up to 300kg/leaf.

|                                     |  |
|-------------------------------------|--|
|                                     |  |
| <b>Denomination</b>                 | M14, M14X EMERGENCY EXIT DEVICE                      |
| <b>Manufacturer</b>                 | Ninz S.p.A. Corso Trento, 2/A I-38061 ALA (TN)/ITALY |
| <b>Year application trademark</b>   | 10   |
| <b>Nr. and year of the standard</b> | EN 179:2008  |
| <b>Certifying body</b>              | 0425   |
| <b>CE certificate Nr.</b>           | 0425-CPR-002148                                      |
| <b>Classification</b>               | <b>3 7 7 B 1 4 4 2 A C</b>                           |

- 1st Category of use very frequent
- 2nd Durability 200.000 cycles
- 3rd Door mass over 200 kg
- 4th Suitable for fire/smoke rated doors
- 5th Safety, suitable for evacuation routes
- 6th High corrosion resistance 240 h
- 7th Material safety 1000 N
- 8th Handle protrusion up to 100 mm
- 9th Activation type with lever handle
- 10th Suited for door: two-leaved, on the inactive leaf only

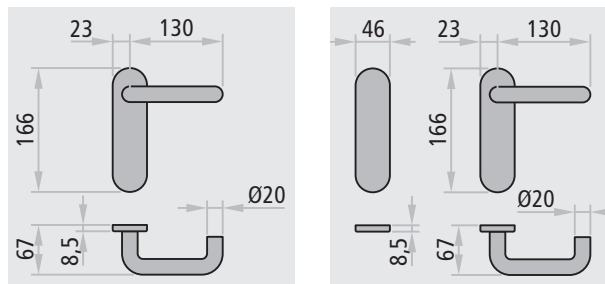

version for Univer/Proget door

version for Rever door

## SUPPLIED TOGETHER WITH THE DOOR

### For the inactive leaf of two-leaved doors:

*Included (mounted on the door):* anti-panic safety lock with 80mm entrance, vertical rods, upper locking device, upper strike plate.

*Included (in the package):* Nr. 1 lever handle in brushed stainless steel with galvanized steel installation plate and blank cover plate in brushed stainless steel (with external installation plate for Rever doors), Nr. 1 square spindle, Nr. 1 floor-mounted door catch, Nr. 1 carrier arm (for fire doors only), fastener screws, Nr. 1 adhesive pictogram (green arrow), Nr. 1 set of instructions for installation/maintenance.

*Versions available:* M14X, M14Xs

## KIT VERSION (SUPPLIED SEPARATELY FROM THE DOOR)

### KIT for the inactive leaf of two-leaved doors:

Please specify the door type - REVER, UNIVER or PROGET - in the order. *KIT contents:* Nr. 1 anti-panic safety lock with 80mm entrance, Nr. 1 lever handle in brushed stainless steel with galvanized steel installation plate and blank cover plate in brushed stainless steel (with external installation plate for Rever doors), Nr. 1 square spindle, Nr. 1 upper locking device (for Rever and Univer multipurpose doors only), Nr. 1 carrier arm (excluding Rever and Univer multipurpose doors), fastener screws, Nr. 1 adhesive pictogram (green arrow), Nr. 1 set of instructions for installation/maintenance.

*Versions available:* M14X, M14Xs

ICIM S.p.A. - Identification number: 0425  
Piazza Don Enrico Mapelli, 75 - 20099 Sesto San Giovanni (MI) - ITALY

### Certificato di costanza delle prestazioni

### Certificate of constancy of performance

Certificato N. **0425 - CPR - 002148**  
Certificate No.

In conformità al Regolamento 305/2011/EU del Parlamento Europeo e del Consiglio del 9 marzo 2011 (Regolamento Prodotti da Costruzione o CPR), questo certificato si applica al prodotto da costruzione descritto nell'Allegato 2A della norma:  
In compliance with Regulation 305/2011/EU of the European Parliament and of the Council of 9 March 2011 (the Construction Products Certification or CPR), this certificate applies to the construction product described in Annex 2A of the standard:

**Dispositivi per uscite di emergenza azionati mediante maniglia a leva o piastra a spinta**  
**Emergency exit devices operated by a lever handle or push pad**

SERIE / SERIES: M14, M14X  
MODELLI / MODELS: See annex

Caratteristiche: vedi Allegato / Characteristics: see Annex  
IMMESSO SUL MERCATO CON IL NOME O IL MARCHIO DI  
PLACED ON THE MARKET UNDER THE NAME OR TRADE MARK OF  
**NINZ S.p.A.**

SEDE LEGALE / HEAD OFFICE: Corso Trento, 2/A 38061 ALA (TN) - IT  
UNITÀ OPERATIVA / PRODUCTION UNIT: Corso Trento, 2/A 38061 ALA (TN) - IT

Questo certificato attesta che tutte le disposizioni riguardanti la valutazione e la verifica della costanza della prestazione e le prestazioni descritte nell'Allegato 2A della norma:  
This certificate attests that all provisions concerning the assessment and verification of constancy of performance and the performances described in Annex 2A of the standard:

**EN 179:2008**  
nell'ambito del sistema 1 di cui al presente certificato vengono applicati e che il controllo di produzione in fabbrica condotto dal produttore è valutato al fine di garantire lo **under system 1 set out in this certificate are applied and that the factory production control conducted by the manufacturer is assessed to ensure the**

**COSTANZA DELLA PRESTAZIONE DEL PRODOTTO DA COSTRUZIONE**  
**CONSTANCY OF PERFORMANCE OF THE CONSTRUCTION PRODUCT**

Questo certificato è stato emesso per la prima volta il 12/03/2010 e ha validità sino a che la norma armonizzata, il prodotto da costruzione, i metodi ACP o le condizioni di produzione nello stabilimento non subiscano modifiche significative, o sino a che non venga sospeso o ritirato dall'organismo di certificazione notificato ICIM S.p.A.  
This certificate was first issued on 12/03/2010 and will remain valid as long as neither the harmonized standard, the construction product, the ACP methods nor the manufacturing conditions in the plant are modified significantly, unless suspended or withdrawn by the notified product certification body ICIM S.p.A.

Il presente Certificato è da ritenersi valido solo se accompagnato dal relativo Allegato / This Certificate is valid only with the relative Annex

**ICIM S.p.A.**  
EMISSIONE / ISSUE: 12/03/2020

ICIM S.p.A. - Piazza Don Enrico Mapelli, 75 - 20099 Sesto San Giovanni (MI)

# EXUS<sup>®</sup>

---

EXUS<sup>®</sup>



# Presentation

EXUS® panic bars

**NINZ**<sup>®</sup>  
FIRE DOORS

## PRESENTATION

### EXUS® panic bars

Ninz S.p.A. is a leader in fire doors, and has once again reasserted itself as a visionary company with a strong identity created by its continuous research into the design and technology of its own products, such as the new line of EXUS® panic bars.

The EXUS® panic bars are CE marked and according to European standard EN 1125:2008-EC1:2009, which entered in effect January 01, 2010, and which prescribes a series of substantial changes that further extend the requirements for maximum safety and ease of opening.

### The KIT designed for your needs

When ordered separately from the door, the EXUS® series of panic bars is provided in elegant and functional KITS packaged for presentation in the most appropriate format for distribution.

Packaging in KITS ensures customers, installers and therefore the final users that they are receiving a complete anti-panic system with fully corresponding parts which are all CE certified.

### Finishing

Attention to detail and proportions are highlighted by select materials and finishing.

In addition to the **black PLASTIC** version combined with **anodized ALUMINIUM** bars, new combinations include the all **brushed STAINLESS STEEL** version and the **polished chromed ALUMINIUM** version combined with the **anodized ALUMINIUM bar**. Many other color and surface combinations are possible for equally aesthetic solutions.

The particular aesthetics of soft forms is one of the exclusive advantages of **EXUS® panic bars**, representing the fruit of designs generated in collaboration with Studio MM Design, which has been working with the company for many years.

### Certifications and replacements

Given the importance of maintaining the entire system's CE conformity, special attention has been paid to replacement parts, which have been subjected to testing in accordance with the EN 1125:2008-EC1:2009 standard due to their pivotal role in maintaining CE certification.

The only way to ensure that the products maintain their original characteristics over time is by using **original NINZ replacement parts**.

For this reason, the instructions for **EXUS® panic bars** include additional indications regarding proper installation and maintenance plus a exploded assembly drawing that specifies every smallest detail of the certified system with all of the references required for ordering replacement parts.

**With the EXUS® panic bar, NINZ S.p.A. demonstrates its willingness to believe in market development by investing in designs and company image in order to endow its own products with added value while maintaining highly competitive quality-price ratios.**



Black PLASTIC handle



Brushed STAINLESS STEEL handle

### NOTE

By default external door furniture is provided with the same finishing as the panic bar.

EXUS®

# EXUS® - Features, certifications

Panic bar

**NINZ**  
FIREDOORS

EXUS®

## FEATURES

- Newly designed product with state of the art technological concept
- Available several in color and surface combinations: brushed stainless steel for the lever arms and the bar, or aluminium with polished chrome lever arms and anodized aluminium bar, and finally the classic ever-green combination - black plastic lever arms with anodized aluminium bar
- Certified for internal lock with 40 or 65mm entrances for single leaves or active leaves, with 30 or 80mm entrance for inactive leaves and with square spindle rotation of up to 45°
- Possibility of locking by key on the bar side as well
- Reversible for Right or Left mounting
- Protrusion 125mm
- Proposed together with the door or separately in a complete KIT packaged in a black/yellow box
- Label applied to the packaging to identify the product's characteristics
- Wide range of customizations: colored bar, colored or stainless steel handles, lock with access control mechanisms, special coded or mastered cylinders

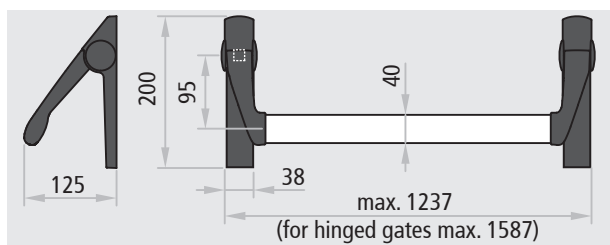

## CERTIFICATION

Suited for one-leaved doors or the active and inactive leaves of two-leaved doors with dimensions up to 1350x2880mm/leaf, mass up to 300kg/leaf.

|                                     |  |
|-------------------------------------|--|
| <b>CE</b>                           |  |
| <b>Denomination</b>                 | EXUS PANIC BAR                                       |
| <b>Manufacturer</b>                 | Ninz S.p.A. Corso Trento, 2/A I-38061 ALA (TN)/ITALY |
| <b>Year application trademark</b>   | 08   |
| <b>Nr. and year of the standard</b> | EN 1125:2008-EC1:2009                                |
| <b>Certifying body</b>              | 0425   |
| <b>CE certificate Nr.</b>           | 0425 CPR-001228                                      |
| <b>Classification</b>               | <b>3 7 7 B 1 3 2 1 A A</b>                           |

- 1st Category of use very frequent
- 2nd Durability 200.000 cycles
- 3rd Door mass over 200 kg
- 4th Suitable for fire/smoke rated doors
- 5th Safety, suitable for evacuation routes
- 6th High corrosion resistance 96 h
- 7th Material safety 1000 N
- 8th Bar protrusion up to 150 mm
- 9th Activation type with push bar
- 10th Suited for one- or two-leaved doors



EXUS® is a registered trademark owned by Ninz S.p.A.

Also suited for doors with fire ratings:



ICIM S.p.A. - Identification number: 0425  
Piazza Don Enrico Mapelli, 75 - 20099 Sesto San Giovanni (MI) - ITALY

**Certificato di costanza delle prestazioni**  
*Certificate of constancy of performance*

Certificato N. **0425 - CPR - 001228**  
Certificata No.

In conformità al Regolamento 305/2011/UE del Parlamento Europeo e del Consiglio del 9 marzo 2011 (Regolamento Europeo di Costruzione o CPR), questo certificato si applica al prodotto da costruzione:  
In compliance with Regulation 305/2011/UE of the European Parliament and of the Council of 9 March 2011 (the Construction Products Directive or CPR), this certificate applies to the construction product:

**Dispositivi per le uscite antipanico azionati mediante una barra orizzontale per l'utilizzo sulle vie di esodo**  
**Panic exit devices operated by a horizontal bar, for use on escape routes**

SERIE / SERIES: TWIST, EXUS LP, EXUS LA, EXUS LX  
MODELLI / MODELS: **Si veda allegato / See annex**

Caratteristiche: vedi Allegato / Characteristics: see Annex  
AMMESSO SUL MERCATO CON IL NOME DI IL MARCO DI PLACED ON THE MARKET UNDER THE NAME OR TRADE MARK OF  
**NINZ S.p.A.**

SEDE LEGALE / HEAD OFFICE: Corso Trento, 2/A - 38061 ALA (TN) - ITALY  
UNITÀ OPERATIVA / PRODUCTION UNIT: Corso Trento, 2/A - 38061 ALA (TN) - ITALY

Questo certificato attesta che alle apparecchiature segnalate si è verificata la conformità delle prestazioni e le prestazioni dichiarate nell'etichetta CE della norma.  
This certificate attests that all products concerning the assessment and verification of constancy of performance and the performance declared in Annex 2A of the standard:

**EN 1125:2008 + EC1:2009**  
nell'ambito del sistema 1 di cui al presente certificato vengono applicati e che il controllo di produzione in fabbrica condotto dal produttore è conforme al fine di garantire che  
under system 1 set out in this certificate are applied and that the factory production control conducted by the manufacturer is operated in accordance with:

**COSTANZA DELLA PRESTAZIONE DEL PRODOTTO DA COSTRUZIONE**  
**CONSTANCY OF PERFORMANCE OF THE CONSTRUCTION PRODUCT**

Questo certificato è stato emesso per la prima volta il 15/04/2007 e ha validità fino a che la norma armonizzata, il prodotto da quotare e i metodi ACQP o le condizioni di produzione nello stabilimento non subiscano modifiche significative, o fino a che non venga annullato o ritirato dall'organismo di certificazione notificato ICIM S.p.A.  
This certificate was first issued on 15/04/2007 and will remain valid as long as neither the harmonized standard, the construction product, the ACQP method nor the manufacturing conditions in the plant are modified significantly, unless suspended or withdrawn by the notified product certification body ICIM S.p.A.

Il presente Certificato è da ritenersi valido solo se accompagnato dal relativo Allegato / This Certificate is valid only with the Annex

ICIM S.p.A.  
Direttore Tecnico  
FIRMAZIONE / SIGNATURE  
22/06/2017

© ICF S.p.A. - Piazza Don Enrico Mapelli, 75 - 20099 Sesto San Giovanni (MI)

### EXUS® LP IN BLACK PLASTIC



#### Description

The EXUS LP panic bar consists of an anodized aluminium horizontal bar that inserts into the lever arms attached to the mechanisms which activate the lock.

- Reversible for right or left opening
- For application to single leaf and two-leaved doors
- Suited for Rever/Univer/Proget doors and other types of panic exit doors
- The horizontal bar is made of extruded anodized aluminium with an elliptical cross-section measuring 40x20mm and a length of 1150mm
- Two black plastic lever arms with galvanized steel core
- The two mechanisms are made of galvanized steel with black plastic carter covers, one of which has an EXIT label that identifies the lock side
- The lock is anti-panic/fire rated for Euro profile cylinders
- The door furnitures and related cover plates are made of black plastic, while the installation plate is made of galvanized steel
- DC version with cylinder to pass

#### VERSIONS AVAILABLE

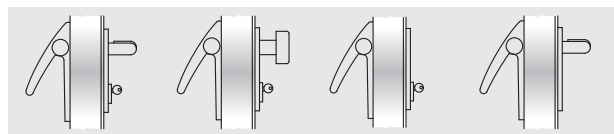

BM

BSP

BS

BMC

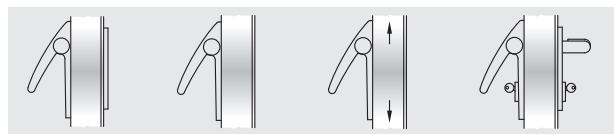

BC

B

A

DC BM

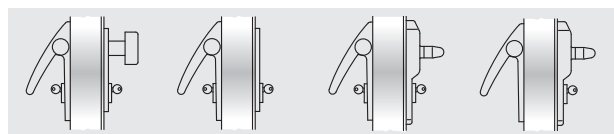

DC BSP

DC BS

DC ELM

ELM

#### VARIATIONS ON REQUEST (see dedicated page)

- Aluminium bar painted in RAL colors
- External BM, BSP, BS, BMC and BC door furnitures in brushed stainless steel, standard or "Sertos" version\* (only for Proget doors)
- External BM and BSP door furnitures painted in RAL colors
- Three-point locking mechanism
- MAC1 panic lock with access control system, combinable with the BM and DC BM versions
- Mastered or coded cylinders
- Microswitch and cable sleeve for signaling when the door is open

### EXUS LP (SUPPLIED WITH THE DOOR)

#### For single leaf or the active leaf of two-leaved doors:

*Included (mounted on the door):* the anti-panic lock with 65mm entrance and the strike box lock insert

*Included (in the package):* Nr. 2 mechanisms, Nr. 2 black plastic carter covers, Nr. 2 black plastic lever arms, Nr. 1 anodized aluminium bar, Nr. 1 black plastic external door furniture, Nr. 1 half-cylinder with 3 keys, Nr. 1 cylinder to pass with 3 keys (DC version only), Nr. 1 drilling template, Nr. 1 adhesive pictogram (green arrow), Nr. 1 set of installation/maintenance instructions

*Versions available:* BM, BSP, BS, BMC, BC, B (for Proget doors only), DC BM, DC BSP, DC BS, DC ELM, ELM

ELM electric handle: see the dedicated pages

#### For the inactive leaf of two-leaved doors:

*Included (mounted on the door):* anti-panic safety lock with 80mm entrance, the upper re-latch device, the upper strike plate and the vertical rods

*Included (in the package):* Nr. 2 mechanisms, Nr. 2 black plastic carter covers, Nr. 2 black plastic lever arms, Nr. 1 anodized aluminium bar, Nr. 1 floor-mounted floor catch, Nr. 1 carrier arm (for fire doors only), Nr. 1 drilling template, Nr. 1 adhesive pictogram (green arrow), Nr. 1 set of installation/maintenance instructions

*Versions available:* A

### EXUS LP KIT

#### (SUPPLIED SEPARATELY FROM THE DOOR)

#### KIT for single leaf or the active leaf of two-leaved doors:

Please specify the door type - REVER, UNIVER or PROGET - in the order.

*KIT contents:* Nr. 1 anti-panic lock with 65mm entrance, Nr. 1 strike box lock insert, Nr. 2 mechanisms, Nr. 2 black plastic carter covers, Nr. 2 black plastic lever arms, Nr. 1 anodized aluminium bar, Nr. 1 black plastic external door furniture, Nr. 1 half-cylinder with 3 keys, Nr. 1 cylinder to pass with 3 keys (DC version only), Nr. 1 drilling template, Nr. 1 adhesive pictogram (green arrow), Nr. 1 set of installation/maintenance instructions

*Versions available:* BM, BSP, BS, BMC, BC, DC BM, DC BSP, DC BS

#### KIT for the inactive leaf of two-leaved doors, suited for REVER, UNIVER and PROGET fire and multipurpose doors (produced after 01.01.2005):

specify door type on the order form

*KIT contents:* Nr. 1 anti-panic safety lock with 80mm entrance, Nr. 2 mechanisms, Nr. 2 black plastic carter covers, Nr. 2 black plastic lever arms, Nr. 1 anodized aluminium bar, Nr. 1 upper re-latch device, Nr. 1 floor-mounted floor catch, Nr. 1 carrier arm (excluding REVER and UNIVER multipurpose), Nr. 1 drilling template, Nr. 1 adhesive pictogram (green arrow), Nr. 1 set of installation/maintenance instructions

*Versions available:* A

#### KIT for the inactive leaf of two-leaved doors and suited for other types of multipurpose doors and for substitution of non CE marked panic bars (PROGET doors):

*KIT contents:* Nr. 1 anti-panic safety lock with 80mm entrance, Nr. 2 mechanisms, Nr. 2 black plastic carter covers, Nr. 2 black plastic lever arms, Nr. 1 anodized aluminium bar, Nr. 1 upper re-latch device, Nr. 1 upper strike plate, vertical rods, Nr. 1 floor-mounted floor catch, Nr. 1 carrier arm, Nr. 1 drilling template, Nr. 1 adhesive pictogram (green arrow), Nr. 1 set of installation/maintenance instructions

*Versions available:* A

\* see "Accessories, stainless steel handles"; in case of "Sertos" version the opening direction needs to be indicated

**EXUS® LA IN ALUMINIUM**

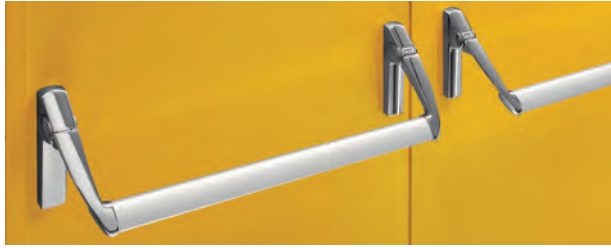

**Description**

The EXUS LA panic bar consists of an anodized aluminium horizontal bar that inserts into lever arms attached to the mechanisms which activate the lock.

- Reversible for right or left opening
- For application to single leaf and two-leaved doors
- Suited for Rever/Univer/Proget doors and other types of panic exit doors
- The horizontal bar is made of extruded anodized aluminium with an elliptical cross-section measuring 40x20mm and a length of 1150mm
- The two lever arms are made of an aluminium alloy with a polished chrome finish
- The two mechanisms are made of galvanized steel with aluminium alloy carter covers with a polished chrome finish, one of which has an EXIT label to identify the lock side
- The lock is anti-panic/fire rated for Euro profile cylinders
- The door furnitures and related cover plates are made of AISI 304 brushed stainless steel, while the installation plate is made of galvanized steel
- The arms and carter covers are finished with tri-valent chrome in compliance with the ROSH regulation
- DC version with cylinder to pass

**VERSIONS AVAILABLE**

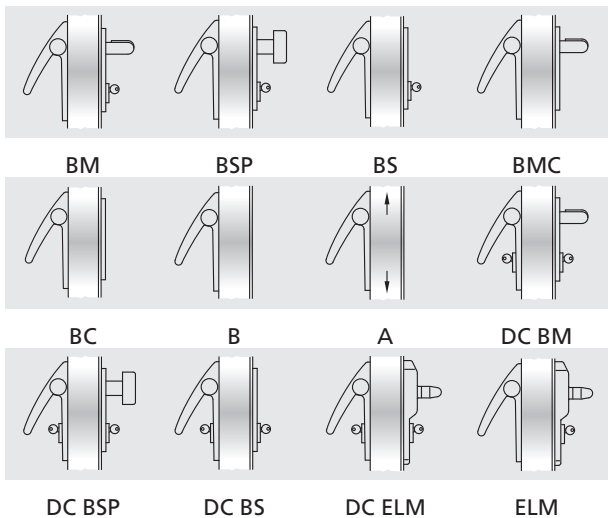

**VARIATIONS ON REQUEST** (see dedicated page)

- Aluminium bar painted in RAL colors
- External BM, BSP, BS, BMC and BC door furnitures in brushed stainless steel, standard or "Sertos" version\* (only for Proget doors)
- Three-point locking mechanism
- MAC1 panic lock with access control system, combinable with the BM and DC BM versions
- Mastered or coded cylinders
- Microswitch and cable sleeve for signaling when the door is open

**EXUS LA (SUPPLIED WITH THE DOOR)**

**For single leaf or the active leaf of two-leaved doors:**

*Included (mounted on the door):* the anti-panic lock with 65mm entrance and the strike box lock insert

*Included (in the package):* Nr. 2 mechanisms, Nr. 2 polished chrome aluminium carter covers, Nr. 2 polished chrome aluminium lever arms, Nr. 1 anodized aluminium bar, Nr. 1 stainless steel external door furniture, Nr. 1 half-cylinder with 3 keys, Nr. 1 cylinder to pass with 3 keys (DC version only), Nr. 1 drilling template, Nr. 1 adhesive pictogram (green arrow), Nr. 1 set of installation/maintenance instructions

*Versions available:* BM, BSP, BS, BMC, BC, B (for Proget doors only), DC BM, DC BSP, DC BS, DC ELM, ELM

ELM electric handle: see the dedicated pages

**For the inactive leaf of two-leaved doors:**

*Included (mounted on the door):* anti-panic safety lock with 80mm entrance, the upper re-latch device, the upper strike plate and the vertical rods

*Included (in the package):* Nr. 2 mechanisms, Nr. 2 polished chrome aluminium carter covers, Nr. 2 polished chrome aluminium lever arms, Nr. 1 anodized aluminium bar, Nr. 1 floor-mounted floor catch, Nr. 1 carrier arm (for fire doors only), Nr. 1 drilling template, Nr. 1 adhesive pictogram (green arrow), Nr. 1 set of installation/maintenance instructions

*Versions available:* A

**EXUS LA KIT**

**(SUPPLIED SEPARATELY FROM THE DOOR)**

**KIT for single leaf or the active leaf of two-leaved doors:**

Please specify the door type - REVER, UNIVER or PROGET - in the order.

*KIT contents:* Nr. 1 anti-panic lock with 65mm entrance, Nr. 1 strike box lock insert, Nr. 2 mechanisms, Nr. 2 polished chrome aluminium carter covers, Nr. 2 polished chrome aluminium lever arms, Nr. 1 anodized aluminium bar, Nr. 1 stainless steel external door furniture, Nr. 1 half-cylinder with 3 keys, Nr. 1 cylinder to pass with 3 keys (DC version only), Nr. 1 drilling template, Nr. 1 adhesive pictogram (green arrow), Nr. 1 set of installation/maintenance instructions

*Versions available:* BM, BSP, BS, BMC, BC, DC BM, DC BSP, DC BS

**KIT for the inactive leaf of two-leaved doors, suited for REVER, UNIVER and PROGET fire and multipurpose doors (produced after 01.01.2005):** specify door type on the order form

*KIT contents:* Nr. 1 anti-panic safety lock with 80mm entrance, Nr. 2 mechanisms, Nr. 2 polished chrome aluminium carter covers, Nr. 2 polished chrome aluminium lever arms, Nr. 1 anodized aluminium bar, Nr. 1 upper re-latch device, Nr. 1 floor-mounted floor catch, Nr. 1 carrier arm (excluding REVER and UNIVER multipurpose), Nr. 1 drilling template, Nr. 1 adhesive pictogram (green arrow), Nr. 1 set of installation/maintenance instructions

*Versions available:* A

**KIT for the inactive leaf of two-leaved doors and suited for other types of multipurpose doors and for substitution of non CE marked panic bars (PROGET doors):**

*KIT contents:* Nr. 1 anti-panic safety lock with 80mm entrance, Nr. 2 mechanisms, Nr. 2 polished chromed aluminium carter covers, Nr. 2 chromed aluminium lever arms, Nr. 1 anodized aluminium bar, Nr. 1 upper re-latch device, Nr. 1 upper strike plate, vertical rods, Nr. 1 floor-mounted floor catch, Nr. 1 carrier arm, Nr. 1 drilling template, Nr. 1 adhesive pictogram (green arrow), Nr. 1 set of installation/maintenance instructions

*Versions available:* A

**NOTE**

It is not advisable to use the anti-panic bar EXUS LA for marine environments or in particularly humid areas. For these situations the use of the anti-panic bar EXUS LX is recommended. \* see "Accessories, stainless steel handles"; in case of "Sertos" version the opening direction needs to be indicated

**EXUS® LX IN STAINLESS STEEL**



**Description**

The entire EXUS LX panic bar is made of stainless steel, and consists of a horizontal bar that inserts into lever arms attached to the mechanisms which activate the lock.

- Maximum corrosion resistance and noteworthy robustness of the entire set
- Optimal aesthetic appearance
- Reversible for right or left opening
- For application to single leaf and two-leaved doors
- Suited for Rever/Univer/Proget doors and other types of panic exit doors
- The horizontal bar is made of AISI 304 brushed stainless steel with an elliptical cross-section measuring 40x20mm, length of 1150mm
- The two lever arms are made of AISI 304 brushed stainless steel
- The two mechanisms are made of AISI 304 stainless steel
- The two carter covers are made of AISI 304 brushed stainless steel, and one is labeled with EXIT to identify the lock side
- The lock is anti-panic/fire rated for Euro profile cylinders
- The door furnitures and related cover plates are made of AISI 304 brushed stainless steel, while the installation plate is made of galvanized steel
- DC version with cylinder to pass

**VERSIONS AVAILABLE**

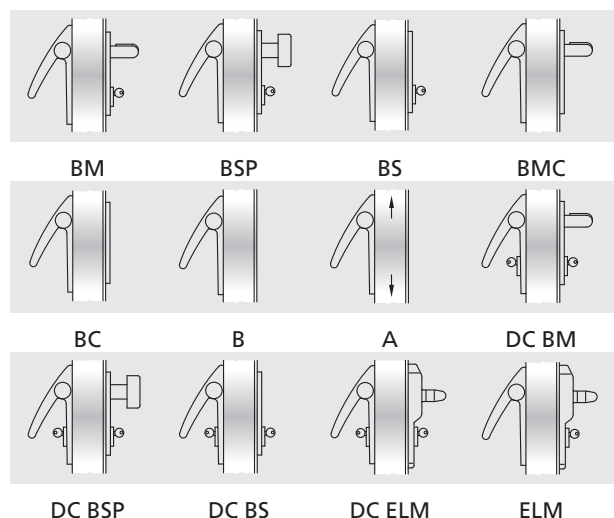

**VARIATIONS ON REQUEST** (see dedicated page)

- External BM, BSP, BS, BMC and BC door furnitures in brushed stainless steel, standard or "Sertos" version\* (only for Proget doors)
- Three-point locking mechanism
- MAC1 panic lock with access control system, combinable with the BM and DC BM versions
- Mastered or coded cylinders
- Microswitch and cable sleeve for signaling when the door is open

**EXUS LX (SUPPLIED WITH THE DOOR)**

**For single leaf or the active leaf of two-leaved doors:**

*Included (mounted on the door):* the anti-panic lock with 65mm entrance and the strike box lock insert

*Included (in the package):* Nr. 2 stainless steel mechanisms, Nr. 2 stainless steel carter covers, Nr. 2 stainless steel lever arms, Nr. 1 stainless steel bar, Nr. 1 stainless steel external door furniture, Nr. 1 half-cylinder with 3 keys, Nr. 1 cylinder to pass with 3 keys (DC version only), Nr. 1 drilling template, Nr. 1 adhesive pictogram (green arrow), Nr. 1 set of installation/maintenance instructions

*Versions available:* BM, BSP, BS, BMC, BC, B (for Proget doors only), DC BM, DC BSP, DC BS, DC ELM, ELM

ELM electric handle: see the dedicated pages

**For the inactive leaf of two-leaved doors:**

*Included (mounted on the door):* anti-panic safety lock with 80mm entrance, the upper re-latch device, the upper strike plate and the vertical rods

*Included (in the package):* Nr. 2 stainless steel mechanisms, Nr. 2 stainless steel carter covers, Nr. 2 stainless steel lever arms, Nr. 1 stainless steel bar, Nr. 1 floor-mounted floor catch, Nr. 1 carrier arm (for fire doors only), Nr. 1 drilling template, Nr. 1 adhesive pictogram (green arrow), Nr. 1 set of installation/maintenance instructions

*Versions available:* A

**EXUS LX KIT (SUPPLIED SEPARATELY FROM THE DOOR)**

**KIT for single leaf or the active leaf of two-leaved doors:**

Please specify the door type - REVER, UNIVER or PROGET - in the order.

*KIT contents:* Nr. 1 anti-panic lock with 65mm entrance, Nr. 1 strike box lock insert, Nr. 2 stainless steel mechanisms, Nr. 2 stainless steel carter covers, Nr. 2 stainless steel lever arms, Nr. 1 stainless steel bar, Nr. 1 stainless steel external door furniture, Nr. 1 half-cylinder with 3 keys, Nr. 1 cylinder to pass with 3 keys (DC version only), Nr. 1 drilling template, Nr. 1 adhesive pictogram (green arrow), Nr. 1 set of installation/maintenance instructions

*Versions available:* BM, BSP, BS, BMC, DC BM, DC BSP, DC BS

**KIT for the inactive leaf of two-leaved doors, suited for REVER, UNIVER and PROGET fire and multipurpose doors (produced after 01.01.2005):** specify door type on the order form

*KIT contents:* Nr. 1 anti-panic safety lock with 80mm entrance, Nr. 2 stainless steel mechanisms, Nr. 2 stainless steel carter covers, Nr. 2 stainless steel lever arms, Nr. 1 stainless steel bar, Nr. 1 upper re-latch device, Nr. 1 floor-mounted floor catch, Nr. 1 carrier arm (excluding REVER and UNIVER multipurpose), Nr. 1 drilling template, Nr. 1 adhesive pictogram (green arrow), Nr. 1 set of installation/maintenance instructions

*Versions available:* A

**KIT for the inactive leaf of two-leaved doors and suited for other types of multipurpose doors and for substitution of non CE marked panic bars (PROGET doors):**

*KIT contents:* Nr. 1 anti-panic safety lock with 80mm entrance, Nr. 2 stainless steel mechanisms, Nr. 2 stainless steel carter covers, Nr. 2 stainless steel lever arms, Nr. 1 stainless steel bar, Nr. 1 upper re-latch device, Nr. 1 upper strike plate, vertical rods, Nr. 1 floor-mounted floor catch, Nr. 1 carrier arm, Nr. 1 drilling template, Nr. 1 adhesive pictogram (green arrow), Nr. 1 set of installation/maintenance instructions

*Versions available:* A

\* see "Accessories, stainless steel handles"; in case of "Sertos" version the opening direction needs to be indicated

# Twist

TWIST

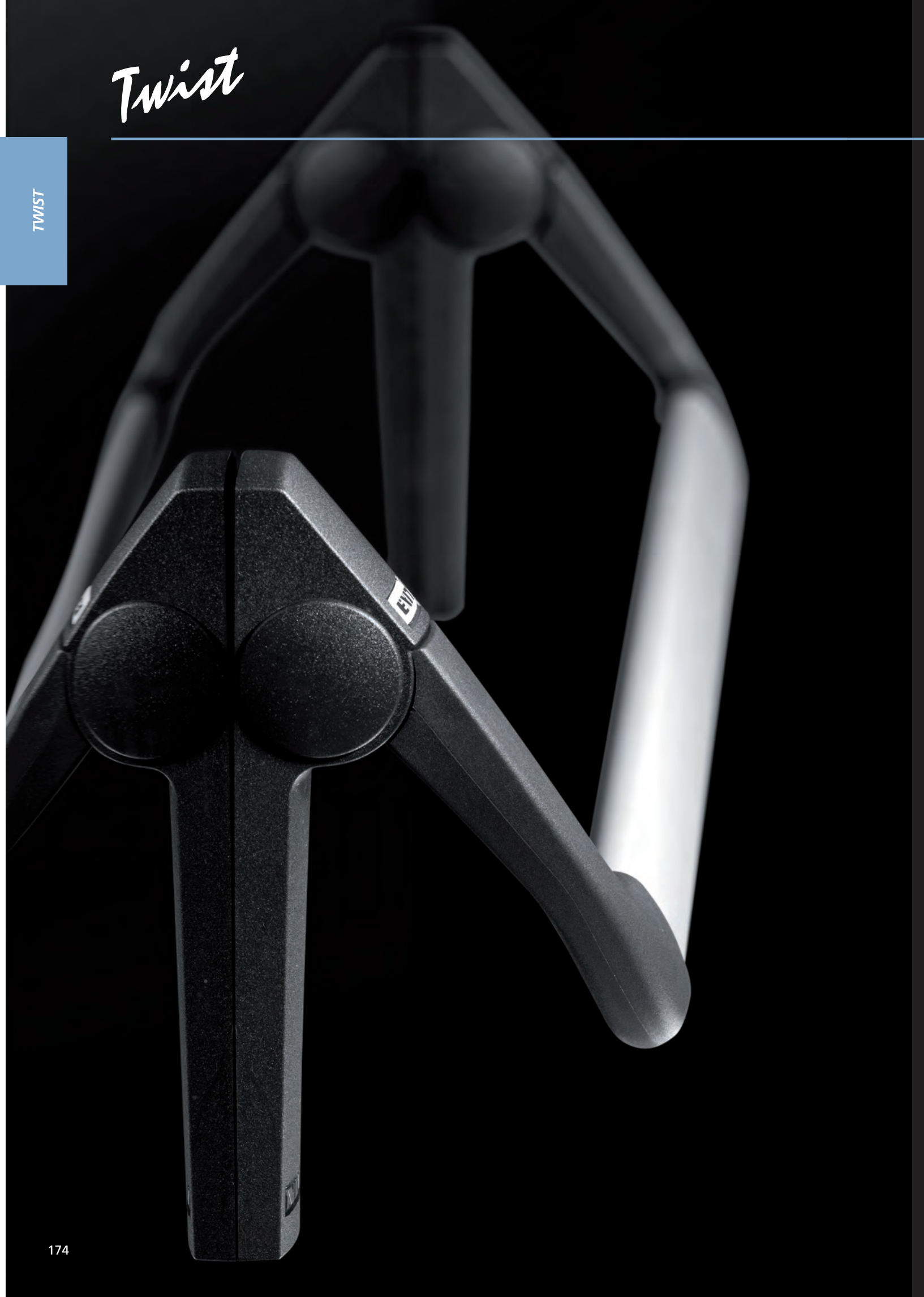

# Presentation

TWIST panic bars

**NINZ**<sup>®</sup>  
FIREDOORS

TWIST

## PRESENTATION

### TWIST panic bars

TWIST panic bars are **CE** marked in accordance with European standard EN 1125:2008-EC1:2009, which entered in effect January 01, 2010, and which prescribes a series of substantial changes that further extend the requirements for maximum safety and ease of opening.

### The KIT designed for your needs

When ordered separately from the door, the **TWIST** series of panic bars is provided in elegant and functional KITS packaged for presentation in the most appropriate format for distribution.

Packaging in KITS ensures customers, installers and therefore the final users that they are receiving a complete anti-panic system with fully corresponding parts that are all **CE** certified.

### Finishing

The **TWIST** panic bar series is proposed in a **black PLASTIC** version combined with an **anodized ALUMINIUM** bar. On request, the bar and the door furniture may be painted in RAL colors, opening up an infinite variety of aesthetic solutions.

### Certifications and replacements

Given the importance of maintaining the entire system's **CE** conformity, special attention has been paid to replacement parts, which have been subjected to testing in accordance with the EN 1125:2008-EC1:2009 standard due to their pivotal role in maintaining **CE** certification.

The only way to ensure that the products maintain their original characteristics over time is by using **original NINZ replacement parts**.

For this reason, the instructions for **TWIST** panic bars include additional indications regarding proper installation and maintenance plus an explosion assembly drawing that specifies every smallest detail of the certified system with all of the references required for ordering replacement parts.

With the packaging of the **TWIST** panic bar, **NINZ S.p.A.** demonstrates its intent to believe in market development by investing in designs and company image in order to endow its own products with added value while maintaining highly competitive quality-price ratios.



Black PLASTIC handle

#### NOTE

The **TWIST** exit device series is combined with a black **PLASTIC** handle.

# TWIST - Features, certifications

Panic bar

**NINZ**  
FIREDOORS

TWIST

## FEATURES

- The classic line of panic bars, an ever-green, available in the standard combination with black plastic arms/caps and anodized aluminium bar
- Certified for internal locks with a 65mm entrance for single leaves or active leaves, and with an 80mm entrance for inactive leaves
- Reversible for mounting on Right or Left doors
- Protrusion 100mm
- Proposed together with the door or separately in a complete KIT packaged in a single black/green box
- Packaging is labeled to identify product characteristics
- Wide range of customizations: colored bar, colored or stainless steel handles, locks with access control systems, special coded or mastered cylinders

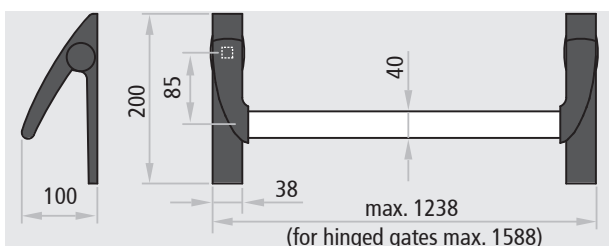

Also suited for doors with fire ratings:

EI,210 REI 120 smoke resistant



## CERTIFICATION

Suited for one-leaved doors or the active and inactive leaves of two-leaved doors with dimensions up to 1350x2880mm/leaf, mass up to 300kg/leaf.

|                                     |  |
|-------------------------------------|--|
|                                     |  |
| <b>Denomination</b>                 | TWIST PANIC BAR                                      |
| <b>Manufacturer</b>                 | Ninz S.p.A. Corso Trento, 2/A I-38061 ALA (TN)/ITALY |
| <b>Year application trademark</b>   | 08   |
| <b>Nr. and year of the standard</b> | EN 1125:2008-EC1:2009                                |
| <b>Certifying body</b>              | 0425   |
| <b>CE certificate Nr.</b>           | 0425 CPR-001228                                      |
| <b>Classification</b>               | <b>3 7 7 B 1 3 2 1 A A</b>                           |

- 1st Category of use very frequent
- 2nd Durability 200.000 cycles
- 3rd Door mass over 200 kg
- 4th Suitable for fire/smoke rated doors
- 5th Safety, suitable for evacuation routes
- 6th High corrosion resistance 96 h
- 7th Material safety 1000 N
- 8th Bar protrusion up to 150 mm
- 9th Activation type with push bar
- 10th Suitable for one- or two-leaved doors



ICIM S.p.A. - Identification number: 0425  
Piazza Don Enrico Mapelli, 75 - 20099 Sesto San Giovanni (MI) - ITALY  
**Certificato di costanza delle prestazioni**  
*Certificate of constancy of performance*

Certificato N. **0425 - CPR - 001228**  
Certificate No.

In conformità al Regolamento 305/2011/CE del Parlamento Europeo e del Consiglio del 9 marzo 2011 (Regolamento Prevalente in materia di CPR), questo certificato si applica al prodotto da costruzione.  
In compliance with Regulation 305/2011/CE of the European Parliament and of the Council of 9 March 2011 (the Construction Products Certification or CPR), this certificate applies to the construction product.

Dispositivi per le uscite antipanico azionati mediante una barra orizzontale per l'utilizzo sulle vie di esodo

Panic exit devices operated by a horizontal bar, for use on escape routes

SERIE / SERIES: TWIST, EXUS LP, EXUS LA, EXUS LX

MODELLO / MODEL: Si veda allegato / See annex

Caratteristiche: vedi Allegato / Characteristics: see Annex  
MARCHIO SUL MERCATO CON IL NOME DI E MARCHE DI  
PLACED ON THE MARKET UNDER THE NAME OR TRADE MARK OF  
**NINZ S.p.A.**

SEDE LEGALE / HEAD OFFICE: Corso Trento, 2/A - 38061 ALA (TN) - ITALY

UNITA OPERATIVA / PRODUCTION UNIT: Corso Trento, 2/A - 38061 ALA (TN) - ITALY

Questo certificato attesta che tutte le disposizioni riportate in valicochere e le verifiche della costante delle prestazioni e le prestazioni descritte nell'Allegato 2A della norma.  
This certificate attests that all provisions concerning the assessment and certification of constancy of performance and the performance described in Annex 2A of the standard.

nell'ambito del sistema 1 di cui al presente certificato vengono applicati e che il controllo di produzione in fabbrica condotto dal produttore è conforme al sistema 1 di cui al presente certificato.  
Within the scope of the system 1 of which the present certificate is issued and that the factory production control conducted by the manufacturer is assessed to ensure the

**COSTANZA DELLA PRESTAZIONE DEL PRODOTTO DA COSTRUZIONE**  
**CONSTANCY OF PERFORMANCE OF THE CONSTRUCTION PRODUCT**

Questo certificato è valido sempre per la prima volta il 15/04/2007 e la validità viene a che la norma armonizzata. Il prodotto da costruzione è marchiato ICIM e le condizioni di produzione sono stabilite non subiscono modifiche significative, o vice è che non venga sospeso o ritardato dall'organismo di certificazione realizzato ICIM S.p.A.  
This certificate is valid from the date of issue on 15/04/2007 and will remain valid as long as neither the harmonized standard, the construction product, the A/C/P method nor the manufacturing conditions in the plant are modified significantly, unless suspension or withdrawal by the notified product certification body ICIM S.p.A.

Il presente Certificato è da considerarsi valido per le applicazioni da sistema Antipanico / This Certificate is valid only with the release Annex

**ICIM S.p.A.**  
Direttore Tecnico

TELEFONO:  
0425/  
**22/08/2017**

ICIM S.p.A. - Piazza Don Enrico Mapelli, 75 - 20099 Sesto San Giovanni (MI)

## TWIST IN BLACK PLASTIC



### Description

The TWIST plastic panic bar consists of an anodized aluminium horizontal bar that inserts into the lever arms attached to the mechanisms used to activate the lock.

- Reversible for right or left opening
- For application to single leaf and two-leaved doors
- Suited for Rever/Univer/Proget doors and other types of panic exit doors
- The horizontal bar is made of extruded anodized aluminium with an elliptical cross-section measuring 40x20mm and a length of 1150mm
- Two black plastic lever arms with galvanized steel core
- The two mechanisms are made of galvanized steel with black plastic carter covers, one of which has an EXIT label that identifies the lock side
- The lock is anti-panic/fire resistance for Euro profile cylinders
- The door furnishings and the cover plates are made of black plastic, while the installation plate is made of galvanized steel

## VERSIONS AVAILABLE

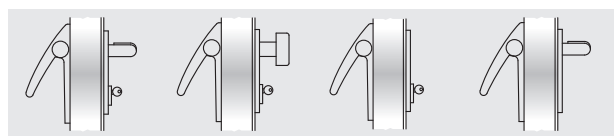

BM

BSP

BS

BMC

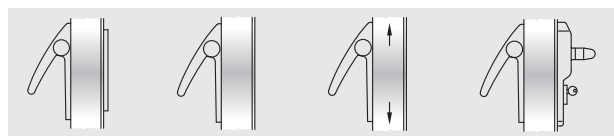

BC

B

A

ELM

## VARIATIONS ON REQUEST (see dedicated page)

- Aluminium bar painted in RAL colors
- External BM, BSP, BS, BMC and BC commands in brushed stainless steel, standard or "Sertos" version\* (only for Proget doors)
- Three-point locking mechanism
- External BM and BSP commands painted in RAL colors
- MAC1 panic lock with access control mode, combinable with the BM version
- Mastered or encrypted cylinders
- Microswitch and cable sleeve for signaling when the door is open

## TWIST (SUPPLIED WITH THE DOOR)

### For single leaf or the active leaf of two-leaved doors:

*Included (mounted on the door):* the anti-panic lock with 65mm entrance and the strike box lock insert

*Included (in the package):* Nr. 2 mechanisms, Nr. 2 black plastic carter covers, Nr. 2 black plastic lever arms, Nr. 1 anodized aluminium bar, Nr. 1 black plastic external door furniture, Nr. 1 half-cylinder with 3 keys, Nr. 1 drilling template, Nr. 1 adhesive pictogram (green arrow), Nr. 1 set of installation/maintenance instructions

*Versions available:* BM, BSP, BS, BMC, BC, B (for Proget doors only), ELM

ELM electric handle: see the dedicated pages

### For the inactive leaf of two-leaved doors:

*Included (mounted on the door):* anti-panic safety lock with 80mm entrance, the upper re-latch device, the upper strike plate and the vertical rods

*Included (in the package):* Nr. 2 mechanisms, Nr. 2 black plastic carter covers, Nr. 2 black plastic lever arms, Nr. 1 anodized aluminium bar, Nr. 1 floor-mounted door catch, Nr. 1 carrier arm (for fire doors only), Nr. 1 drilling template, Nr. 1 adhesive pictogram (green arrow), Nr. 1 set of installation/maintenance instructions

*Versions available:* A

## TWIST KIT

### (SUPPLIED SEPARATELY FROM THE DOOR)

#### KIT for single leaf or the active leaf of two-leaved doors:

Please specify the door type - REVER, UNIVER or PROGET - in the order.

*KIT contents:* Nr. 1 anti-panic lock with 65mm entrance, Nr. 1 strike box lock insert, Nr. 2 mechanisms, Nr. 2 black plastic carter covers, Nr. 2 black plastic lever arms, Nr. 1 anodized aluminium bar, Nr. 1 black plastic external door furniture, Nr. 1 half-cylinder with 3 keys, Nr. 1 drilling template, Nr. 1 adhesive pictogram (green arrow), Nr. 1 set of installation/maintenance instructions

*Versions available:* BM, BSP, BS, BMC, BC

#### KIT for the inactive leaf of two-leaved doors, suited for REVER, UNIVER and PROGET fire and multipurpose doors (produced after 01.01.2005):

specify door type on the order form

*KIT contents:* Nr. 1 anti-panic safety lock with 80mm entrance, Nr. 2 mechanisms, Nr. 2 black plastic carter covers, Nr. 2 black plastic lever arms, Nr. 1 anodized aluminium bar, Nr. 1 upper re-latch device, Nr. 1 floor-mounted floor catch, Nr. 1 carrier arm (excluding REVER and UNIVER multipurpose), Nr. 1 drilling template, Nr. 1 adhesive pictogram (green arrow), Nr. 1 set of installation/maintenance instructions

*Versions available:* A

#### KIT for the inactive leaf of two-leaved doors and suited for other types of multipurpose doors and for substitution of non CE marked panic bars (PROGET doors):

*KIT contents:* Nr. 1 anti-panic safety lock with 80mm entrance, Nr. 2 mechanisms, Nr. 2 black plastic carter covers, Nr. 2 black plastic lever arms, Nr. 1 anodized aluminium bar, Nr. 1 upper re-latch device, Nr. 1 upper strike plate, vertical rods, Nr. 1 floor-mounted floor catch, Nr. 1 carrier arm, Nr. 1 drilling template, Nr. 1 adhesive pictogram (green arrow), Nr. 1 set of installation/maintenance instructions

*Versions available:* A

\* see "Accessories, stainless steel handles"; in case of "Sertos" version the opening direction needs to be indicated

**SLASH**

SLASH

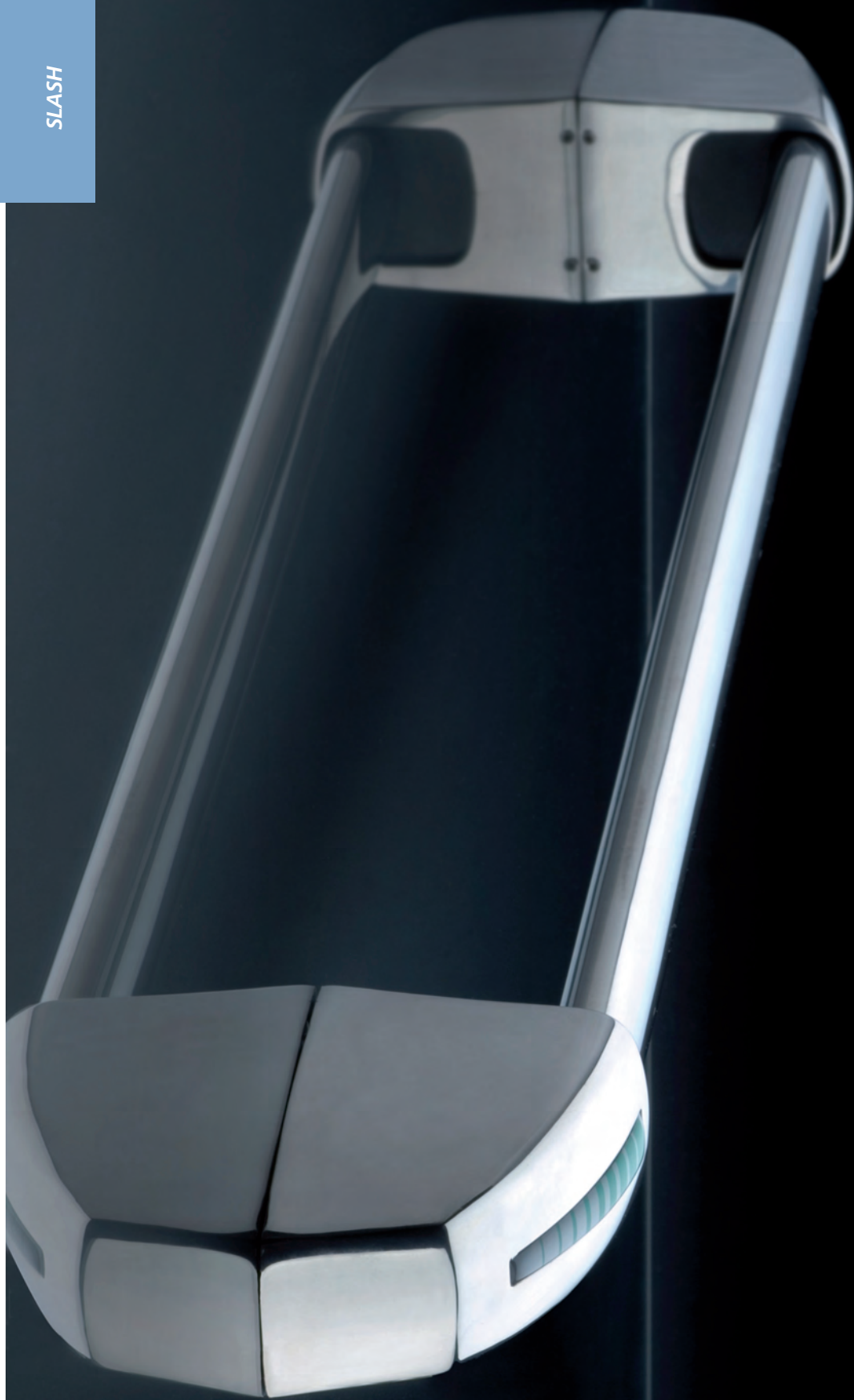

# Presentation

SLASH panic bars

**NINZ**<sup>®</sup>  
FIREDOORS

SLASH

## PRESENTATION

### SLASH panic bars

Ninz S.p.A. is a leader in fire doors, and has once again reasserted itself as a visionary company with a strong identity created by its continuous research into the design and technology of its own products, such as the new line of SLASH panic bars.

All SLASH handles are **CE** marked and pre-certified according to European standard EN 1125:2008-EC1:2009, which entered in effect January 01, 2010, to prescribe a series of substantial changes that further extend the requirements for maximum safety and ease of opening.

### The KIT designed for your needs

When ordered separately from the door, the **SLASH** series of panic bars is provided in elegant and functional KITS packaged for presentation in the most appropriate distribution format.

Packaging in KITS ensures customers, installers and therefore the final users that they are receiving a complete anti-panic system with fully corresponding parts that are all **CE** certified.

### Finishing

In addition to the **black PLASTIC** version combined with **anodized ALUMINIUM** bars, new combinations include the **brushed STAINLESS STEEL** version and the **polished chromed ALUMINIUM** version combined with the **anodized ALUMINIUM bar**. Many other color and surface combinations are possible for equally aesthetic solutions.

### Certifications and replacements

Given the importance of maintaining the entire system's **CE** conformity, special attention has been paid to replacement parts, which have been subjected to testing in accordance with the EN 1125:2008-EC1:2009 standard due to their pivotal role in maintaining **CE** certification.

The only way to ensure that the products maintain their original characteristics over time is by using **original NINZ replacement parts**.

For this reason, the instructions for **SLASH** panic bars include additional indications regarding proper installation and maintenance plus a blow-up drawing that specifies every smallest detail of the certified system with all of the references required for ordering replacement parts.

With the expansion of the line and the packaging of the **SLASH** panic bar, NINZ S.p.A. demonstrates its faith in market development by investing in designs and company image in order to endow its fire doors and the series of accessories with added value while continuing to maintain highly competitive quality-price ratios.

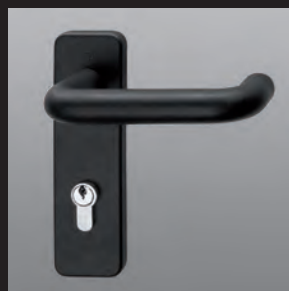

Black PLASTIC handle

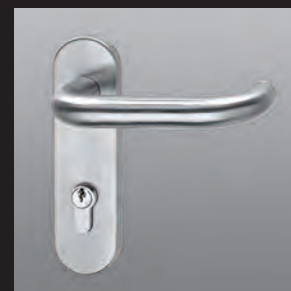

Brushed STAINLESS STEEL handle

### NOTE

By default external door furniture is provided with the same finishing as the panic bar.

# SLASH - Features, certifications

Panic bar



SLASH

## FEATURES

- Panic bar that stands out from the others due to its particular design and the rounded shapes of the carters. This characteristic not only improves aesthetic appeal, but it also eliminates any risk of injury during use
- Available in different color and surface combinations, in brushed stainless steel for the cover carters and the bar, or with polished chromed aluminium carters and anodized aluminium bar, and then there is always the classic combination that is still in fashion - black plastic carters with anodized aluminium bar
- Certified for internal locks with a 65mm entrance for single leaves or active leaves, and with an 80mm entrance for inactive leaves
- Reversible for Right or Left mounting
- Protrusion 75mm
- Proposed together with the door or separately in a complete KIT packaged in a single black/orange box
- Label applied to the packaging to identify the product's characteristics
- Wide range of customizations: colored bar, colored or stainless steel handles, lock with access control mechanisms, special encrypted or mastered cylinders

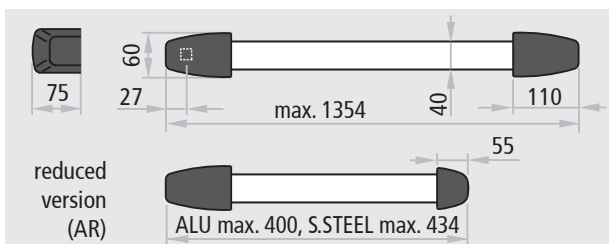

Also suited for doors with classifications up to:



## CERTIFICATION

Suited for one-leaved doors or the active and inactive leaves of two-leaved doors with dimensions up to 1350x2880mm/leaf, mass up to 300kg/leaf.

|                                     |  |
|-------------------------------------|--|
|                                     |  |
| <b>Denomination</b>                 | SLASH PANIC BAR                                      |
| <b>Manufacturer</b>                 | Ninz S.p.A. Corso Trento, 2/A I-38061 ALA (TN)/ITALY |
| <b>Year application trademark</b>   | 08   |
| <b>Nr. and year of the standard</b> | EN 1125:2008-EC1:2009                                |
| <b>Certifying body</b>              | 0425   |
| <b>CE certificate Nr.</b>           | 0425-CPR-001308                                      |
| <b>Classification</b>               | <b>3 7 7 B 1 3 2 2 B A</b>                           |

- 1st Category of use very frequent
- 2nd Durability 200.000 cycles
- 3rd Door mass over 200 kg
- 4th Suitable for fire/smoke rated doors
- 5th Safety, suitable for evacuation routes
- 6th High corrosion resistance 96 h
- 7th Material safety 1000 N
- 8th Bar protrusion up to 100 mm
- 9th Activation type with touch bar
- 10th Suitable for one- or two-leaved doors



ICIM S.p.A. - Identification number: 0425  
Piazza Don Enrico Mapelli, 75 - 20099 Sesto San Giovanni (MI) - ITALY  
**Certificato di costanza delle prestazioni**  
Certificate of constancy of performance

Certificato N. 0425 - CPR - 001308  
Certificate No.

In conformità al Regolamento (CE) del Parlamento Europeo e del Consiglio del 9 marzo 2011 (Regolamento Prodotti da Costruzione o CPR), questo certificato si applica al prodotto da costruire in conformità con il Regolamento (CE) del Parlamento Europeo e del Consiglio del 9 marzo 2011 (Regolamento Prodotti da Costruzione o CPR). This certificate applies to the construction product.

Dispositivi per le uscite antipanico azionati mediante una barra orizzontale per l'utilizzo sulle vie di esodo  
Panic exit devices operated by a horizontal bar, for use on escape routes  
SLASH, SLASH AR, SLASH ALU, SLASH ALU AR, SLASH INOX, SLASH INOX AR  
SILNIE / SERIES

MODELLI / MODELS: Si veda allegato / See annex

Caratteristiche vedi Allegato / Characteristics see Annex  
MARCHIO SUL MERCATO CON IL NOME O IL MARCHIO IN PLACES ON THE MARKET UNDER THE NAME OR TRADE MARK OF

**NINZ S.p.A.**

SEDE LEGALE / HEAD OFFICE: Corso Trento, 2/A - 38061 ALA (TN) - ITALY

UNITA OPERATIVA / PRODUCTION UNIT: Corso Trento, 2/A - 38061 ALA (TN) - ITALY

Questo certificato attesta che tutte le disposizioni Aggettive e le verifiche della costanza delle prestazioni e le verifiche di stabilità di fine di garanzia sono state rispettate.

This certificate attests that all provisions concerning the assessment and verification of constancy of performance and the assessment described in Annex 2A of the standard

EN 1125:2008 + EC1:2009

in conformità del sistema 1 di cui al presente certificato vengono applicate e che il prodotto in fabbrica sottoposto alle procedure di controllo di fine di garanzia è conforme al sistema 1 di cui al presente certificato.

under system 1 all set in this certificate are applied and that the factory production control conducted by the manufacturer is planned to ensure this.

**COSTANZA DELLA PRESTAZIONE DEL PRODOTTO DA COSTRUZIONE**  
CONSTANCY OF PERFORMANCE OF THE CONSTRUCTION PRODUCT

Questo certificato è stato emesso per la prima volta il 21/05/2007 e la validità sino a che la norma armonizzata, il prodotto da costruire, i metodi ACQP e le condizioni di produzione nella fabbricazione non subiscano modifiche significative, o sino a che non venga sospeso o ritirato dall'organismo di certificazione nazionale ICIM S.p.A.

This certificate was first issued on 21/05/2007 and will remain valid as long as neither the harmonized standard, the construction product, the ACQP methods nor the manufacturing conditions in the plant are modified significantly, unless suspended or withdrawn by the issuing product certification body ICIM S.p.A.

Il presente certificato è di natura valida solo se accompagnato da questo Allegato / This Certificate is valid only with the attachment

ICIM S.p.A.

Direttore Tecnico

ESADUE

22/06/2017

ICIM S.p.A. - Piazza Don Enrico Mapelli, 75 - 20099 Sesto San Giovanni (MI)

### SLASH IN BLACK PLASTIC



#### Description

The SLASH panic bar consists of an anodized aluminium horizontal bar and an internal connection tube that inserts into the mechanisms which activate the lock.

- Reversible for right or left opening
- For application to single leaf and two-leaved doors
- Suited for Rever/Univer/Proget doors and other types of panic exit doors
- The horizontal bar is made of extruded anodized aluminium with an elliptical cross-section measuring 40x20mm and a length of 1150mm, equipped with a connection tube
- The two mechanisms are made of galvanized steel with black plastic carter covers, one of which has a green label that identifies the lock side
- The lock is anti-panic/fire rated for Euro profile cylinders
- The door furnitures and the cover plates are made of black plastic, while the installation plate is made of galvanized steel

#### VERSIONS AVAILABLE

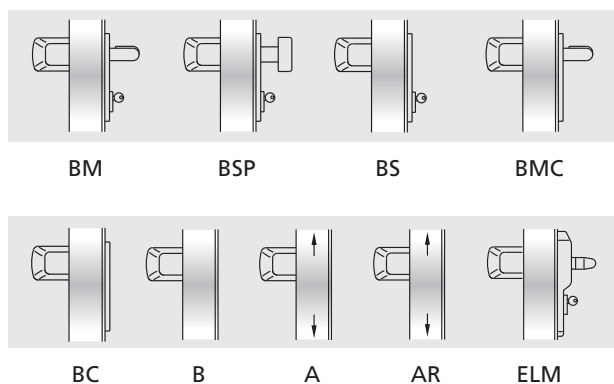

#### VARIATIONS ON REQUEST (see dedicated page)

- Aluminium bar painted in RAL colors
- External BM, BSP, BS, BMC and BC commands in brushed stainless steel, standard or "Sertos" version\* (only for Proget doors)
- Three-point locking mechanism
- External BM and BSP commands painted in RAL colors
- MAC1 panic lock with access control mode, combinable with BM versions
- Mastered or encoded cylinders
- Microswitch and cable sleeve for signaling when the door is open

\* see "Accessories, stainless steel handles"; in case of "Sertos" version the opening direction needs to be indicated

### SLASH (SUPPLIED WITH THE DOOR)

#### For single leaf or the active leaf of two-leaved doors:

*Included (mounted on the door):* the anti-panic lock with 65mm entrance and the strike box lock insert

*Included (in the package):* Nr. 2 mechanisms, Nr. 2 black plastic carter covers, Nr. 1 anodized aluminium bar with connection tube and spacer, Nr. 1 hole cover in RAL 9006 colored plastic with base plate (for REVER and UNIVER doors), Nr. 1 black plastic external door furniture, Nr. 1 half-cylinder with 3 keys, Nr. 1 drilling template, Nr. 1 adhesive pictogram (green arrow), Nr. 1 set of installation/maintenance instructions

*Versions available:* BM, BSP, BS, BMC, BC, B (for Proget doors only), ELM  
ELM electric handle: see the dedicated pages

#### For the inactive leaf of two-leaved doors:

*Included (mounted on the door):* anti-panic safety lock with 80mm entrance, the upper re-latch device, the upper strike plate and the vertical rods

*Included (in the package):* Nr. 2 mechanisms, Nr. 2 black plastic carter covers, Nr. 1 anodized aluminium bar with connection tube and spacer, Nr. 1 floor-mounted floor catch, Nr. 1 carrier arm (for fire doors only), Nr. 1 drilling template, Nr. 1 adhesive pictogram (green arrow), Nr. 1 set of installation/maintenance instructions

*Versions available:* A, AR (reduced) for inactive leaves with FM L2 width ≤ 500mm

### SLASH KIT (SUPPLIED SEPARATELY FROM THE DOOR)

#### KIT for single leaf or the active leaf of two-leaved doors:

Please specify the door type - REVER, UNIVER or PROGET - in the order.

*KIT contents:* Nr. 1 anti-panic lock with 65mm entrance, Nr. 1 strike box lock insert, Nr. 2 mechanisms, Nr. 2 black plastic carter covers, Nr. 1 anodized aluminium bar with connection tube and spacer, Nr. 1 hole cover in RAL 9006 colored plastic with base plate, Nr. 1 black plastic external door furniture, Nr. 1 half-cylinder with 3 keys, Nr. 1 drilling template, Nr. 1 adhesive pictogram (green arrow), Nr. 1 set of installation/maintenance instructions

*Versions available:* BM, BSP, BS, BMC, BC

#### KIT for the inactive leaf of two-leaved doors, suited for REVER, UNIVER and PROGET fire and multipurpose doors (produced after 01.01.2005):

specify door type on the order form

*KIT contents:* Nr. 1 anti-panic safety lock with 80mm entrance, Nr. 2 mechanisms, Nr. 2 black plastic carter covers, Nr. 1 anodized aluminium bar with connection tube and spacer, Nr. 1 upper re-latch device, Nr. 1 floor-mounted floor catch, Nr. 1 carrier arm (excluding REVER and UNIVER multipurpose), Nr. 1 drilling template, Nr. 1 adhesive pictogram (green arrow), Nr. 1 set of installation/maintenance instructions

*Versions available:* A, AR (reduced) for use with inactive leaves with FM L2 width ≤ 500mm

#### KIT for the inactive leaf of two-leaved doors and suited for other types of multipurpose doors and for substitution of non CE marked panic bars (PROGET doors):

*KIT contents:* Nr. 1 anti-panic safety lock with 80mm entrance, Nr. 2 mechanisms, Nr. 2 black plastic carter covers, Nr. 1 anodized aluminium bar with connection tube and spacer, Nr. 1 upper re-latch device, Nr. 1 upper strike plate, vertical rods, Nr. 1 floor-mounted floor catch, Nr. 1 carrier arm, Nr. 1 drilling template, Nr. 1 adhesive pictogram (green arrow), Nr. 1 set of installation/maintenance instructions

*Versions available:* A, AR (reduced) for use with inactive leaves with FM L2 width ≤ 500mm

**SLASH IN ALUMINIUM**



**Description**

The SLASH ALU panic bar consists of an anodized aluminium horizontal bar and an internal connection tube that inserts into the mechanisms which activate the lock.

- Reversible for right or left opening
- For application to single leaf and two-leaved doors
- Suited for Rever/Univer/Proget doors and other types of panic exit doors
- The horizontal bar is made of extruded anodized aluminium with an elliptical cross-section measuring 40x20mm and a length of 1150mm, equipped with a connection tube
- The two mechanisms are made of galvanized steel with aluminium alloy carter covers with polished chrome finishing, one of which has a green label to identify the lock side
- The lock is anti-panic/fire rated for Euro profile cylinders
- The external door furnitures and related cover plates are made of AISI 304 brushed stainless steel, while the installation plate is made of galvanized steel
- The carters are finished with tri-valent chrome in compliance with the ROOSH regulation

**NOTE**

It is not advisable to use the anti-panic bar SLASH ALU for marine environments or in particularly humid areas. For these situations the use of the anti-panic bar SLASH S.S. is recommended.

**VERSIONS AVAILABLE**

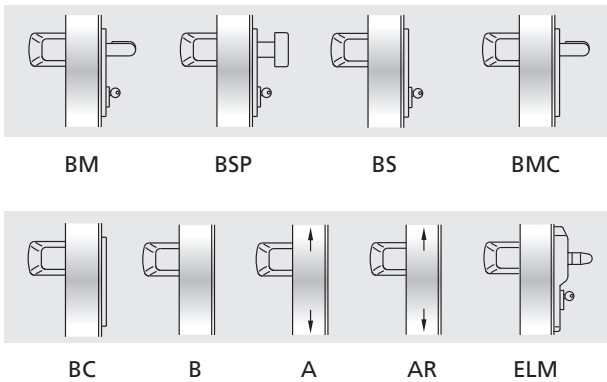

**VARIATIONS ON REQUEST** (see dedicated page)

- Aluminium bar painted in RAL colors
- External BM, BSP, BS, BMC and BC commands in brushed stainless steel, standard or "Sertos" version\* (only for Proget doors)
- Three-point locking mechanism
- MAC1 panic lock with access control system, combinable with BM versions
- Mastered or encoded cylinders
- Microswitch and cable sleeve for signaling when the door is open

**SLASH ALU (SUPPLIED WITH THE DOOR)**

**For single leaf or the active leaf of two-leaved doors:**

*Included (mounted on the door):* the anti-panic lock with 65mm entrance and the strike box lock insert

*Included (in the package):* Nr. 2 mechanisms, Nr. 2 polished chrome aluminium carter covers, Nr. 1 anodized aluminium bar with connection tube and spacer, Nr. 1 hole cover in black plastic with base plate (for REVER and UNIVER doors), Nr. 1 stainless steel external door furniture, Nr. 1 half-cylinder with 3 keys, Nr. 1 drilling template, Nr. 1 adhesive pictogram (green arrow), Nr. 1 set of installation/maintenance instructions

*Versions available:* BM, BSP, BS, BMC, BC, B (for Proget doors only), ELM ELM electric handle: see the dedicated pages

**For the inactive leaf of two-leaved doors:**

*Included (mounted on the door):* anti-panic safety lock with 80mm entrance, the upper re-latch device, the upper strike plate and the vertical rods

*Included (in the package):* Nr. 2 mechanisms, Nr. 2 polished chrome aluminium carter covers, Nr. 1 anodized aluminium bar with connection tube and spacer, Nr. 1 floor-mounted floor catch, Nr. 1 carrier arm (for fire doors only), Nr. 1 drilling template, Nr. 1 adhesive pictogram (green arrow), Nr. 1 set of installation/maintenance instructions

*Versions available:* A, AR (reduced) for inactive leaves with FM L2 width ≤ 500mm

**SLASH ALU KIT (SUPPLIED SEPARATELY FROM THE DOOR)**

**KIT for single leaf or the active leaf of two-leaved doors:**

Please specify the door type - REVER, UNIVER or PROGET - in the order.

*KIT contents:* Nr. 1 anti-panic lock with 65mm entrance, Nr. 1 strike box lock insert, Nr. 2 mechanisms, Nr. 2 polished chrome aluminium carter covers, Nr. 1 anodized aluminium bar with connection tube and spacer, Nr. 1 hole cover in black plastic with base plate, Nr. 1 stainless steel external door furniture, Nr. 1 half-cylinder with 3 keys, Nr. 1 drilling template, Nr. 1 adhesive pictogram (green arrow), Nr. 1 set of installation/maintenance instructions

*Versions available:* BM, BSP, BS, BMC, BC

**KIT for the inactive leaf of two-leaved doors, suited for REVER, UNIVER and PROGET fire and multipurpose doors (produced after 01.01.2005):** specify door type on the order form

*KIT contents:* Nr. 1 anti-panic safety lock with 80 mm entrance, Nr. 2 mechanisms, Nr. 2 polished chrome aluminium carter covers, Nr. 1 anodized aluminium bar with connection tube and spacer, Nr. 1 upper re-latch device, Nr. 1 floor-mounted floor catch, Nr. 1 carrier arm (excluding REVER and UNIVER multipurpose), Nr. 1 drilling template, Nr. 1 adhesive pictogram (green arrow), Nr. 1 set of installation/maintenance instructions

*Versions available:* A, AR (reduced) for use with inactive leaves with FM L2 width ≤ 500mm

**KIT for the inactive leaf of two-leaved doors and suited for other types of multipurpose doors and for substitution of non CE marked panic bars (PROGET doors):**

*KIT contents:* Nr. 1 anti-panic safety lock with 80mm entrance, Nr. 2 mechanisms, Nr. 2 polished chromed aluminium carter covers, Nr. 1 anodized aluminium bar with connection tube and spacer, Nr. 1 upper re-latch device, Nr. 1 upper strike plate, vertical rods, Nr. 1 floor-mounted floor catch, Nr. 1 carrier arm, Nr. 1 drilling template, Nr. 1 adhesive pictogram (green arrow), Nr. 1 set of installation/maintenance instructions

*Versions available:* A, AR (reduced) for use with inactive leaves with FM L2 width ≤ 500mm

\* see "Accessories, stainless steel handles"; in case of "Sertos" version the opening direction needs to be indicated

## SLASH IN STAINLESS STEEL



### Description

The SLASH STAINLESS STEEL panic bar consists of a stainless steel horizontal bar and an internal connection tube that inserts into the mechanisms which activate the lock.

- Optimal corrosion and shock resistance
- State of the art aesthetics
- Secure attachment of carter covers
- Reversible for right or left opening
- For application to single leaf and two-leaved doors
- Suited for Rever/Univer/Proget doors and other types of panic exit doors
- The horizontal bar is made of AISI 304 brushed stainless steel with a 40x20mm elliptical cross-section and a length of 1150mm, equipped with a connection tube
- The two mechanisms are made of galvanized steel with AISI 304 stainless steel cover plates, one of which has a green label that identifies the lock side
- The lock is anti-panic/fire rated for Euro profile cylinders
- The external door furnitures and related cover plates are made of AISI 304 brushed stainless steel, while the installation plate is made of galvanized steel

## VERSIONS AVAILABLE

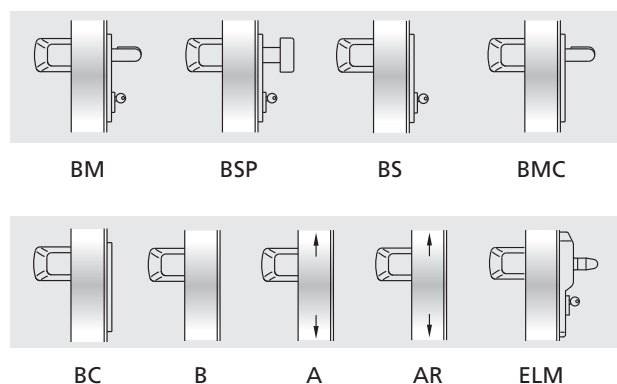

## VARIATIONS ON REQUEST (see dedicated page)

- External BM, BSP, BS, BMC and BC commands in brushed stainless steel, standard or "Sertos" version\* (only for Proget doors)
- Three-point locking mechanism
- MAC1 panic lock with access control system, combinable with BM versions
- Mastered or coded cylinders
- Microswitch and cable sleeve for signaling when the door is open

\* see "Accessories, stainless steel handles"; in case of "Sertos" version the opening direction needs to be indicated

## SLASH STAINLESS STEEL (SUPPLIED WITH THE DOOR)

### For single leaf or the active leaf of two-leaved doors:

*Included (mounted on the door):* the anti-panic lock with 65mm entrance and the strike box lock insert

*Included (in the package):* Nr. 2 mechanisms, Nr. 2 stainless steel carter covers, Nr. 1 stainless steel bar with connection tube and spacer, Nr. 1 hole cover in black-colored plastic with base plate (for REVER and UNIVER doors), Nr. 1 stainless steel external door furniture, Nr. 1 half-cylinder with 3 keys, Nr. 1 drilling template, Nr. 1 adhesive pictogram (green arrow), Nr. 1 set of installation/maintenance instructions

*Versions available:* BM, BSP, BS, BMC, BC, B (for Proget doors only), ELM ELM electric handle: see the dedicated pages

### For the inactive leaf of two-leaved doors:

*Included (mounted on the door):* anti-panic safety lock with 80mm entrance, the upper re-latch device, the upper strike plate and the vertical rods

*Included (in the package):* Nr. 2 mechanisms, Nr. 2 stainless steel carter covers, Nr. 1 stainless steel bar with connection tube and spacer, Nr. 1 floor-mounted floor catch, Nr. 1 carrier arm (for fire doors only), Nr. 1 drilling template, Nr. 1 adhesive pictogram (green arrow), Nr. 1 set of installation/maintenance instructions

*Versions available:* A, AR (reduced) for inactive leaves with FM L2 width ≤ 500mm

## SLASH STAINLESS STEEL KIT (SUPPLIED SEPARATELY FROM THE DOOR)

### KIT for single leaf or the active leaf of two-leaved doors:

Please specify the door type - REVER, UNIVER or PROGET - in the order.

*KIT contents:* Nr. 1 anti-panic lock with 65mm entrance, Nr. 1 strike box lock insert, Nr. 2 mechanisms, Nr. 2 stainless steel carter covers, Nr. 1 stainless steel bar with connection tube and spacer, Nr. 1 hole cover in black plastic with base plate, Nr. 1 stainless steel door furniture, Nr. 1 half-cylinder with 3 keys, Nr. 1 drilling template, Nr. 1 adhesive pictogram (green arrow), Nr. 1 set of installation/maintenance instructions

*Versions available:* BM, BSP, BS, BMC, BC

### KIT for the inactive leaf of two-leaved doors, suited for REVER, UNIVER and PROGET fire and multipurpose doors (produced after 01.01.2005):

*KIT contents:* Nr. 1 anti-panic safety lock with 80mm entrance, Nr. 2 mechanisms, Nr. 2 stainless steel carter covers, Nr. 1 stainless steel bar with connection tube and spacer, Nr. 1 upper re-latch device, Nr. 1 floor-mounted floor catch, Nr. 1 carrier arm (excluding REVER and UNIVER multipurpose), Nr. 1 drilling template, Nr. 1 adhesive pictogram (green arrow), Nr. 1 set of installation/maintenance instructions

*Versions available:* A, AR (reduced) for use with inactive leaves with FM L2 width ≤ 500mm

### KIT for the inactive leaf of two-leaved doors and suited for other types of multipurpose doors and for substitution of non CE marked panic bars (PROGET doors):

*KIT contents:* Nr. 1 anti-panic safety lock with 80mm entrance, Nr. 2 mechanisms, Nr. 2 stainless steel cover plates, Nr. 1 stainless steel bar with connection tube and spacer, Nr. 1 upper re-latch device, Nr. 1 upper strike plate, vertical rods, Nr. 1 floor-mounted floor catch, Nr. 1 carrier arm, Nr. 1 drilling template, Nr. 1 adhesive pictogram (green arrow), Nr. 1 set of installation/maintenance instructions

*Versions available:* A, AR (reduced) for use with inactive leaves with FM L2 width ≤ 500mm

# General information

## Panic bars - System components

### COMPONENTS OF THE CERTIFIED SYSTEM

All NINZ panic bars are supplied in complete KITS to ensure conformity with EN 1125:2008-EC1:2009 standards and CE certification of the product. When supplied together with the door, several of these components are already mount-

ed on the leaf and/or doorframe.

The purpose of the following examples is to help clarify what panic bars must include to comply with certified samples.

#### Certified components of the EXUS system for one-leaved doors:

1. panic bar (1a. mechanisms, 1b. carters, 1c. carrier arms, 1d. horizontal bar, 1e. adhesive pictogram)
- 2a. panic safe lock for single or active leaf
3. strike box lock
4. external operation
- 9a. square spindle
10. half cylinder or cylinder to pass

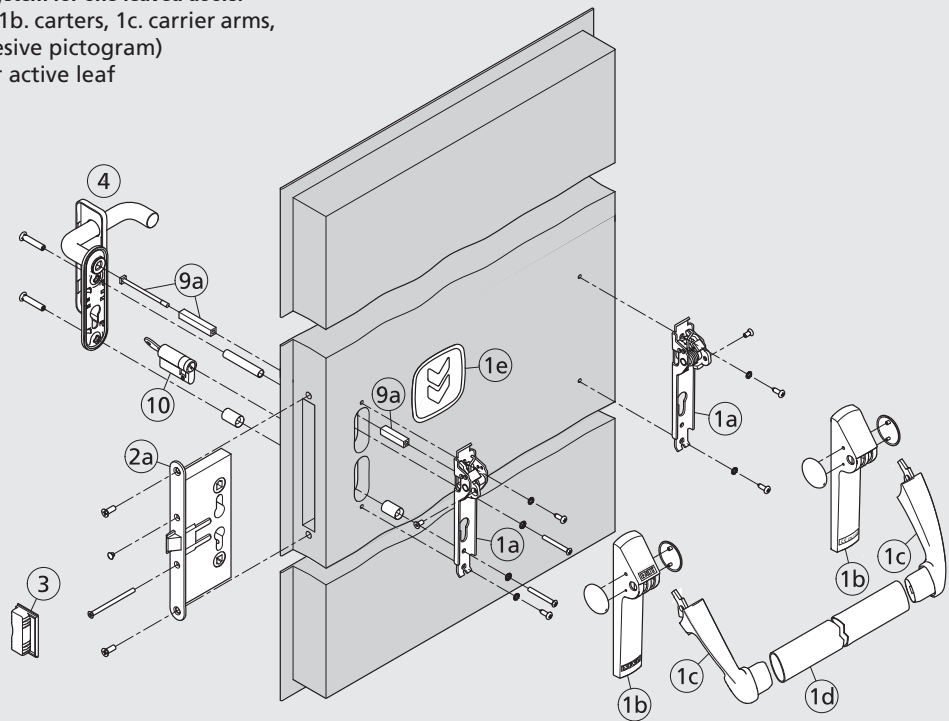

#### Certified components of the EXUS system for inactive leaf of two-leaved doors:

1. panic bar (1a. mechanisms, 1b. carters, 1c. carrier arms, 1d. horizontal bar, 1e. adhesive pictogram)
- 2b. panic safe lock for inactive leaf
5. upper bolt device
6. strike box with roller
7. floor catch set
8. vertical rods (8a. upper, 8b. lower)
- 9b. square spindle
11. carrier arm (mandatory in case of fire-rated doors only)

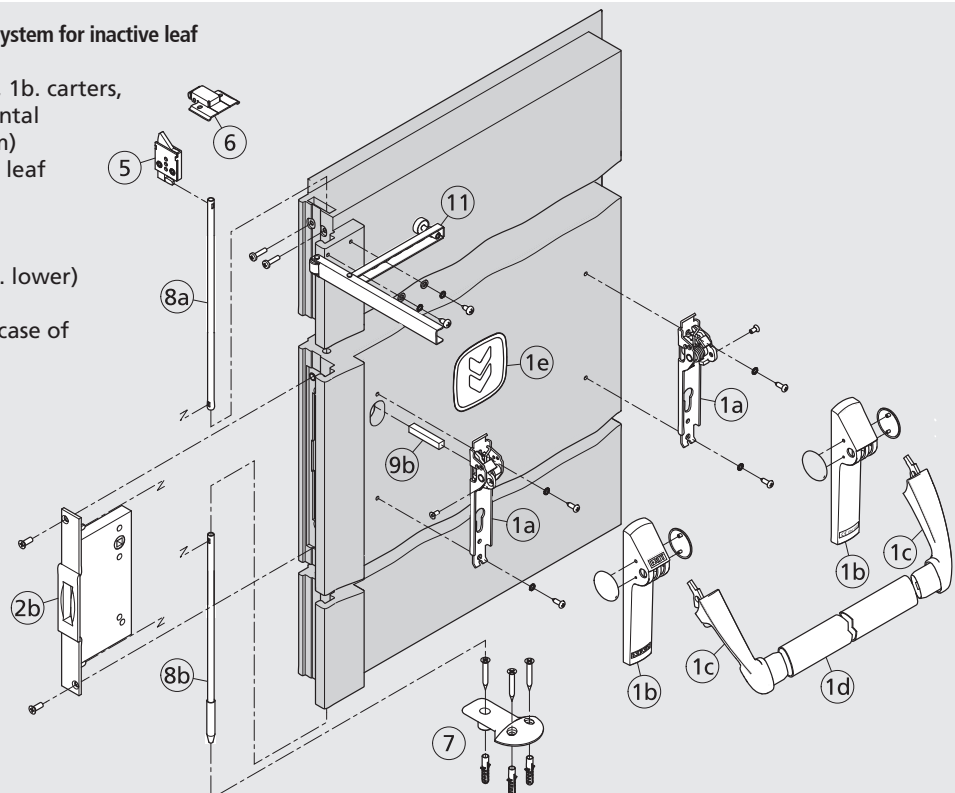

# Variations on request

For panic bars

## STAINLESS STEEL EXTERNAL DOOR FURNITURE

For all black plastic exit devices, brushed stainless steel external BM, BSP, BS BMC and BC commands are available on request with standard or „Sertos“ mechanism.

**NOTE**  
see “Accessories, stainless steel handles”; in case of “Sertos” mechanism the opening direction needs to be indicated



BM stainless steel

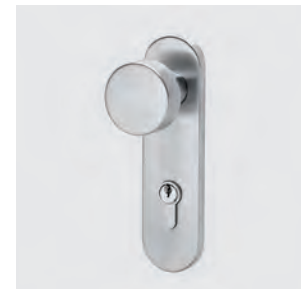

BSP stainless steel

## COLORED PLASTIC EXTERNAL DOOR FURNITURE

For all black plastic exit devices (except for those designed for glazed doors), painted plastic external BM and BSP commands are available on request.

Colors available:

| RAL  | RAL  | RAL  | RAL   | RAL  |
|------|------|------|-------|------|
| 1023 | 7016 | 7035 | 9006* | 9010 |
|      |      |      |       |      |

\*light aluminium



BM colored RAL1023

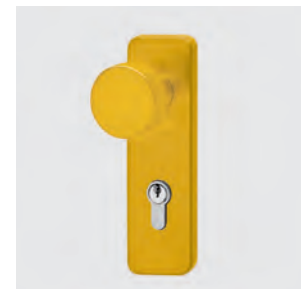

BSP colored RAL1023

## PAINTED HORIZONTAL BAR

For all exit devices (except for those with a stainless steel bar), the aluminium horizontal bar may be painted in the RAL color of your choice.



## VERSION „E“ WITH MICROSWITCH

All exit devices may be equipped with a microswitch incorporated in the hinge side mechanism for signaling when the door is open. The cable and cable sleeve for the electrical connection between the exit device and the wall are included.



## MAC1<sup>®</sup> AND MAC1<sup>®</sup> FAILSAFE ACCESS CONTROL SYSTEMS

For all exit devices with type BM external door furniture (except for those designed for glazed doors), the panic lock is also available with the access control function. Delivery together with the door includes the following: the MAC1 or MAC1 FAILSAFE lock, external command with LED, internal cabling of the leaf and the electric contacts between the door leaf and door frame. In case of delivery as a Kit with panic bar instead of the internal cabling and the electric contacts a power supply cable and a flexible cable sleeve will be supplied.



Handle for MAC1 and MAC1 FAILSAFE locks with LEDs

For sizes, information and technical data consult the dedicated pages

# Dimensional drawings

For panic bar components

| Article Nr. | Description  |
|-------------|--|
| 3201001.016 | Lock for one-leaved doors and active leaves (AP 16/18)                         |
| 3201001.024 | Safety lock for inactive leaves UNIVER and PROGET (AP 020 P)                   |
| 3201001.008 | Safety lock for inactive leaves of REVER (AP 020 U)                            |
| 3201001.041 | MAC1 Left lock   |
| 3201001.042 | MAC1 Right lock  |
| 2401001.001 | Lower floor catch for inactive leaf of PROGET and other multipurpose doors     |
| 3105019.001 | Lower floor catch for inactive leaf of UNIVER                                  |
| 3105020.001 | Lower floor catch for inactive leaf of REVER                                   |
| 2401006.001 | Strike plate insert for one-leaved PROGET and other multipurpose doors         |
| 3105080.001 | Upper re-latch device for inactive leaf of PROGET and other multipurpose doors |
| 3105024.001 | Upper re-latch device for inactive leaf of UNIVER and REVER                    |
| 2401046.001 | Upper strike box for inactive leaf of PROGET and other multipurpose doors      |
| 3305001.001 | Carrier arm for inactive leaf  |

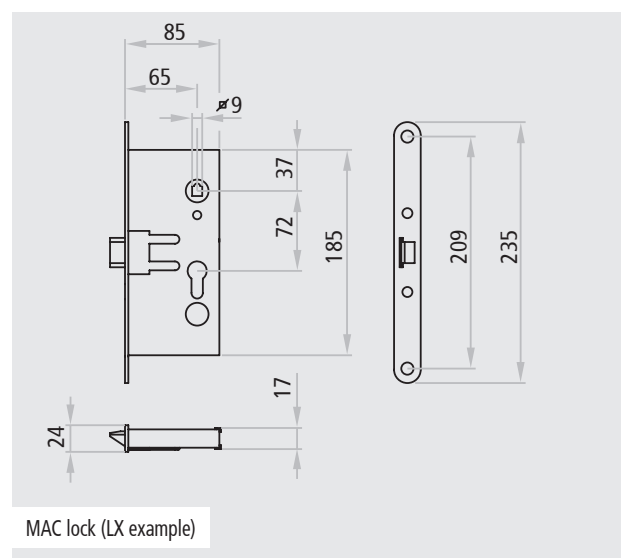
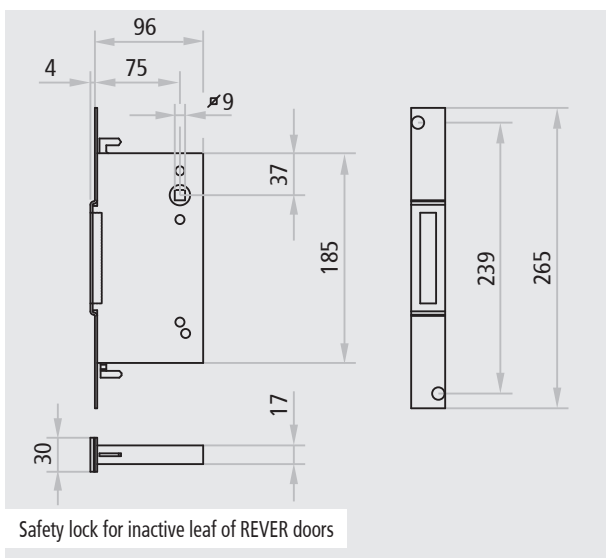
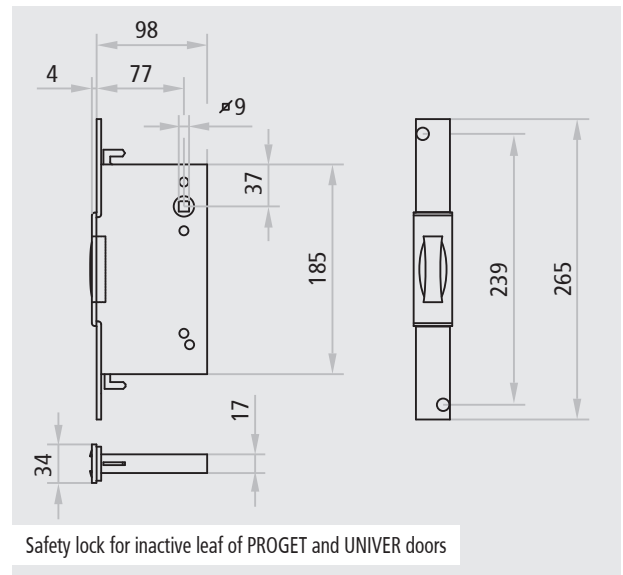
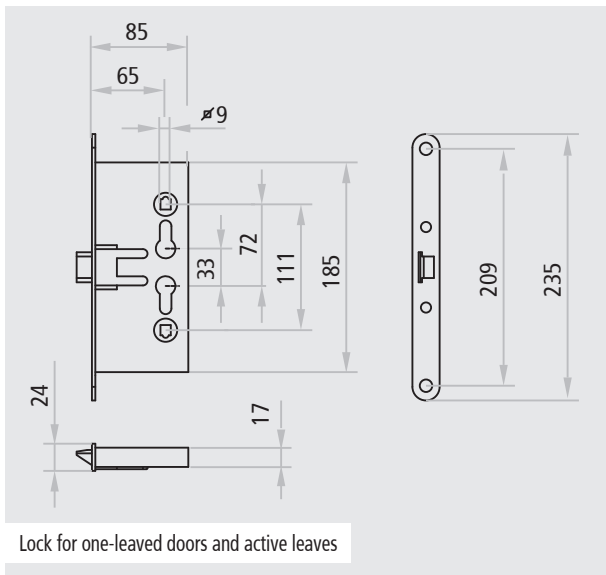

# Dimensional drawings

For panic bar components

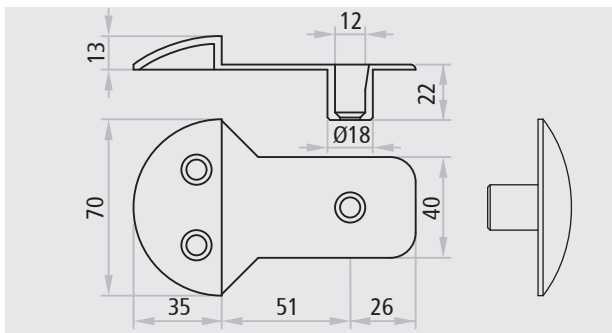

Lower floor catch for inactive leaf of PROGET and other multipurpose doors

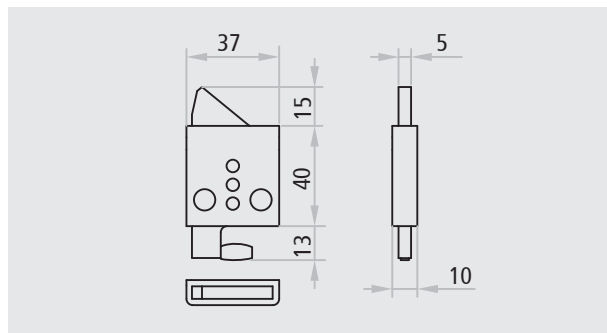

Upper re-latch device for inactive leaf of PROGET and other multipurpose doors

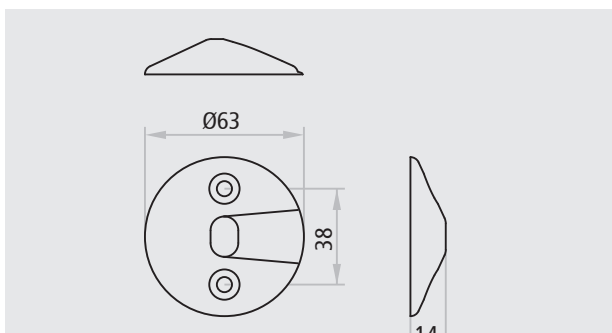

Lower floor catch for inactive leaf of UNIVER

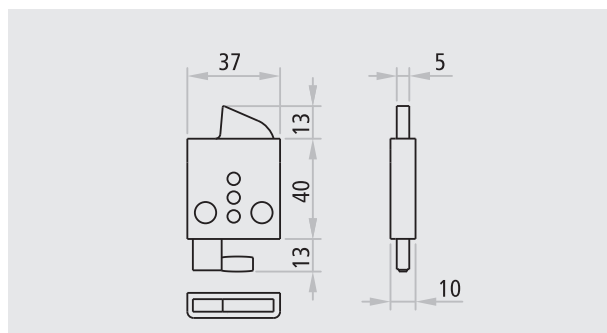

Upper re-latch device for inactive leaf of UNIVER and REVER

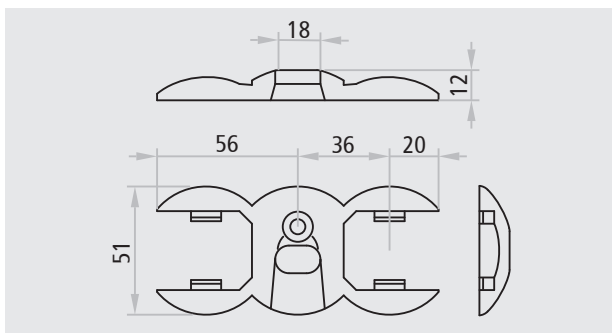

Lower floor catch for inactive leaf of REVER

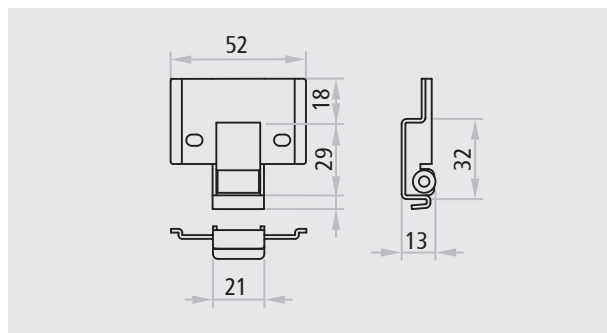

Upper strike box for inactive leaf of PROGET and other multipurpose doors

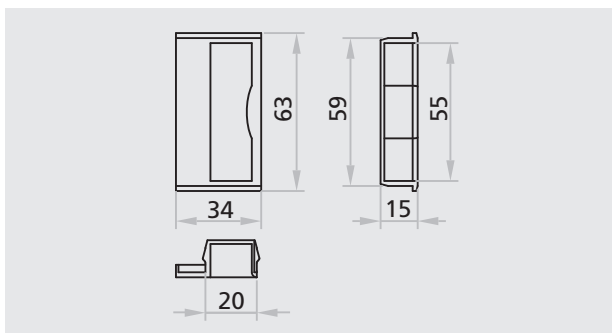

Strike box lock insert for one-leaved doors of PROGET and other multipurpose doors

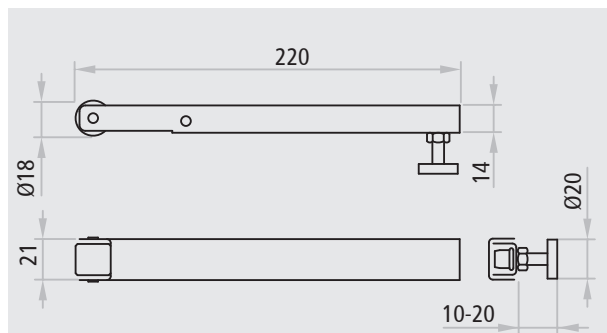

Carrier arm for inactive leaf

## GENERAL INFORMATION

The technical specifications in this brochure and also the "Notices" section of the following chapter, are of basic importance in order to have the necessary information about the characteristics of Ninz products that will be ordered. As reported in the order forms or confirmations, buyer must declare to be aware of these specifications.

A complete and updated version of this brochure, as well as all documents related to fire doors or CE marked doors (certificates of conformity, installation instructions, DOP documents, etc.) are available and downloadable from the website [www.ninz.it](http://www.ninz.it).

Ninz reserves the right to make unannounced technical changes to the contents of this brochure and/or to its products, without any obligation to prior announcements.

No reproduction (partial or total) of the current brochure is allowed without prior authorization by Ninz.

If not specified, the measurements indicated in the current brochure are in millimeters, unless otherwise indicated.

Because of the intrinsicities of the printing process the colors depicted in this brochure may not correspond exactly to the colors of actual doors. Please see RAL or NCS samples.

The performance values listed in the current brochure have been reached with tests according to the current norms. The customer shall acknowledge that these may change according to:

- real installation conditions
- adjustments of leeway
- connections between door and wall
- execution of the wall itself

The standard handle requires assembly (supplied not installed on the door).



The colors shown on the photos are not standard.

Handles, panic bars, cylinders, sealings, door closers, closing regulators, anchors, stainless steel protective-/kick-plates, drip steel profile and others are optional accessories and are supplied not installed onto the door.

The handle height positions indicated in the brochure are those standard. For special requests, please contact the Ninz sales department.

A summary of the standards about emergency exit devices or panic devices for safety exits is published in the current brochure and must be respected by all operators.

## Meaning of used abbreviations or symbols

| Abbreviation or symbol  | meaning                       | comments                                    |
|---|-------------------------------|---|
| Ø   | diameter                      |   |
| DX  | right                         | opening direction                           |
| FFL   | finished floor level          |   |
| FM  | ordering dimension            | may be different to the wall opening        |
| FPC   | plasterboard wall opening     | dimension of the wall opening to be created |
| H   | height                        |   |
| L   | width                         |   |
| L1  | division of the active leaf   | nominal dimension                           |
| L2  | division of the inactive leaf | nominal dimension                           |
| PT  | doorframe opening             |   |
| SX  | left                          | opening direction                           |
|  | internal pedestrian door      |   |
|  | external door                 |   |

## Meaning of used measurement units

| Abbreviation | meaning                          | comments                       |
|--------------|----------------------------------|--------------------------------|
| °C           | Celsius degree                   | temperature                    |
| A, mA, µA    | Ampère, milliAmpère, microAmpère | intensity of the current („I") |
| AC           | (Volt) alternating current       | voltage                        |
| DC           | (Volt) direct current            | voltage                        |
| h            | hour                             | time                           |
| Kg o kg      | kilogram                         | weight                         |
| m, mm        | meter, millimeter                | dimension                      |
| nr.          | number                           | quantity                       |
| sec.         | second                           | time                           |
| V            | Volt                             | electric potential             |

## INSTALLATION AREA

Ninz products are typically used for internal compartmentalization and have been designed for this purpose. For this reason they must be stored and installed sheltered from direct contact of atmospheric agents and sunlight.

In cases where a product is installed for external use, in order to avoid deteriorations over time, it is mandatory to take some precautions, in particular:

- select a painting suitable for exterior use
- select fire-rated glass suitable for exterior use
- provide canopies or roofing above installed products

Only in this way it is possible to avoid any water seeping inside the goods and/or any warping of metal parts, especially in case of darker colours.

For products that incorporate REI or EI fire-rated glass, regardless of whether they are suitable for exterior use, it is further necessary to consider that:

- fire-rated glass remains stable in the range of temperature between -40°C and +50°C; exceeding this limits, the fire resistant interlayer of the glass reacts and begins to become opaque over the whole surface. Therefore it is necessary to avoid the installation near any heat source greater than 50°C and/or any lighting that may generate UV radiation
- exposure to high level of humidity may cause seeps inside of the layers, thus generating a dissolution of the interlayer. Therefore it is necessary to avoid the installation in areas with high level of humidity

It is not advisable to use the anti-panic bars EXUS LA or SLASH ALU for marine environments or in particularly humid areas. For these situations the use of the anti-panic bars EXUS LX or SLASH S.S. is recommended.

Buyers should be aware that, pursuant to and in accordance with Italian Legislative Decree D.L. 09.04.2008 Nr. 81, all doors used for emergency exits or escape routes must have a minimum height of 2000mm.

All products must be installed onto supporting walls which are perfectly vertical, well aligned and onto levelled flooring.

In order to not hinder the self-closing of fire-rated doors it is moreover important that the installation area is not subject to strong air currents.

For the automatic closing of doors exposed to strong winds, the use of a door closer with a higher closing force is recommended.

The installation can be considered conform only with prior verification that the walls are in good conditions.

Related to the weight of the products, it is moreover necessary to consider preventively:

- to verify the resistance, the load bearing capacity and the fastening suitability of the walls, divisions, structures and/or crossbeams related to the installation
- that the end-user may face difficulties operating the doors, especially people with reduced mobility (disabled, seniors, in poor health, etc.). It is important to take this factor into consideration, therefore while planning the use of products and/or to always hold the leaves open by means of electromagnets

The protrusion of accessoires (for ex. handles, door closers, etc.), in case of interference with walls or other compartmentalizations, could compromise the opening of the leaf and/or create damages. In order to avoid that, buyers shall provide appropriate indents in the walls and in any case the installation of appropriate door stoppers.

## INSTALLATION, USE AND MAINTENANCE

Installation of every Ninz product must be performed by specialized technicians only, using all supplied and described components, strictly in accordance with the installation, use and maintenance handbook or with the installation instructions supplied by Ninz with the products.

Any installation modifications allowed for door and/or accessoires are only those that are indicated in the installation, use and maintenance handbook, which contain also the list of elements that have been tested and approved for use.

For the maintenance and/or repair of the Ninz products use original spare parts only which are listed in the installation instructions and also in price list.

The above mentioned notices are of basic importance to provide a high level of safety for human and for goods and in compliance with relevant norms.

## GLAZED FIRE-RATED PRODUCTS

REI or EI fire-rated glazed panels are submitted to rigorous quality controls during every stage of the production process. Minor optical imperfections or tiny air bubbles may be present due to the particular manufacturing process of the fire-rated glass. This does not compromise the fire resistance of the glass and does not constitute grounds for claims.

**Steam cleaning is strictly forbidden for fire-rated windows.**

**NINZ**  
FIREDOORS



Ninz S.p.A. | Corso Trento 2/A | I-38061 Ala (TN)  
Tel. +39 0464 678 300 | Fax +39 0464 679 025  
info@ninz.it | www.ninz.it